

# ram reports in applied measurement

## Measuring torque on an engine test stand

Arnold Berger,  
Thomas Trebitsch,  
Frank C. Otto,  
AVL LIST GmbH, Graz, Austria

### General

It is not just the acquisition of the mechanical torque variables, it is also the integration into a mechanical overall system that are crucial. The overall view determines system suitability in performance test stands.

### Introduction

Over the last few years, the continued development of internal combustion engines has moved to a range in which the measurable difference is getting smaller and smaller. This development is also reflected in the development of measuring instruments, where the actual measurement accuracy is always an interaction of several components, even those that do not have an obvious immediate effect on the torque measurement chain.

In addition to this, the increased use of dynamic engine test stands that allow the simulation of vehicle-like load conditions for the engines has led to increasing demands on the torque measurement signal with regard to acquisition speed and accuracy, as well as on the control of the E-machine. The example of the dynamic engine test stand shows that the correct acquisition of the torque signal has a direct bearing on the achievable vehicle or drive train simulation quality.

In preparation for the measurement of torque on the engine test stand, there are two different approaches, both of which have their advantages and disadvantages and are therefore applied accordingly. After all, the choice must be made for each application within the relevant constraints. The report that follows

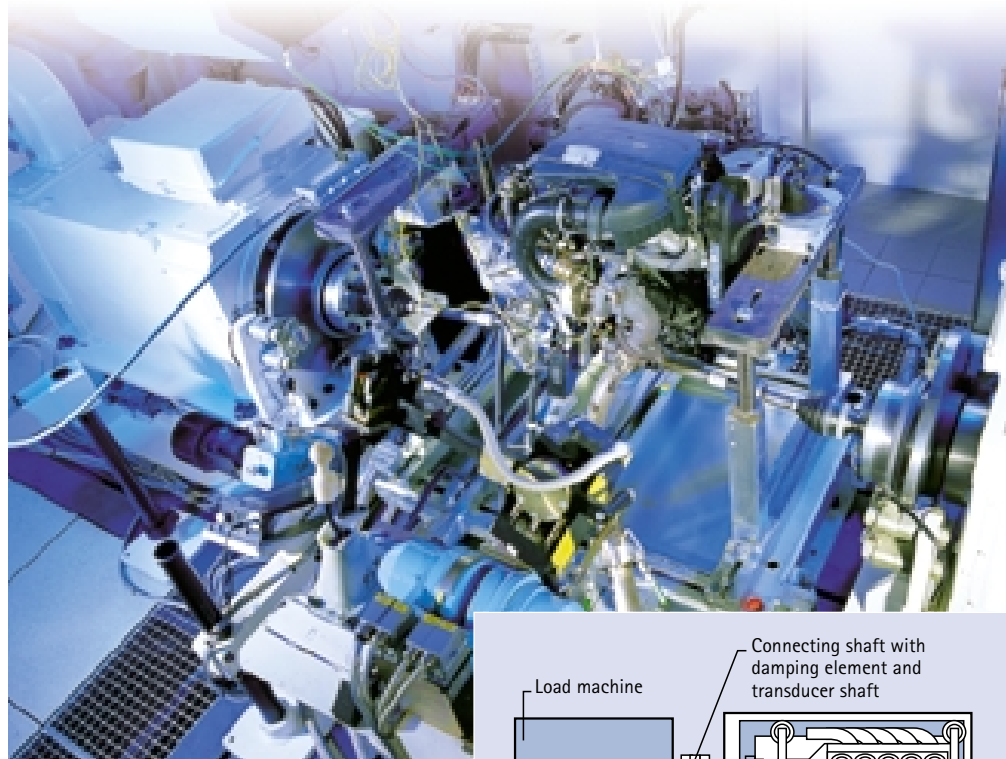

Fig. 1a: Power test stand with integrated torque flanges

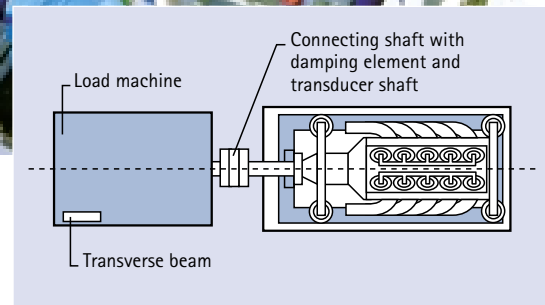

Fig. 2a: Basic structure of a typical engine test stand

tries to provide a general overview of application.

### Measuring torque by means of pendulum bearings

The reaction torque is measured at a stator with pendulum bearings by means of lever arm on a load cell. The applied force measuring instrument, usually a load cell or a transverse beam, records the reaction moment of the stator with pendulum bearings against the rotor. In most cases, the measuring device is simultaneously the braking or driving unit.

A further developed version is described here in place of the pendulum drive application:

### Asynchronous pendulum drive (APA)

As already mentioned in the introduction, the dynamic engine test stand makes great demands on torque measurement. On this type of test stand, the internal combustion engine is connected directly with the E-machine by its flywheel and a connecting shaft with a vibration damping element. The control and simulation unit EMCON/ISAC, developed by AVL, controls the E-machine in such a way that real vehicle-like load conditions can be realized for the engine, without having to set up the vehicle drive train on the test stand. For this simulation, as well as a vehicle model with relevant data to simulate the drive train including gearbox and clutch, a faster drive is

also required to act as a dynamic and exact torque actuator and also to control the shaft moment.

The mechanical connection between the E-machine and the engine also has to meet certain requirements. The natural frequency in the standard application should typically be set at 15 to 25Hz and it is advisable to use a suitable damping element. Shaft moment signals with a higher frequency than this natural frequency will be damped by the spring-mass-system: machine – shaft connection with damping device – internal combustion engine.

If the torque were recorded by a transducer shaft, this would produce a limit frequency for the actual value signal of 15 to 25Hz. We will look at the mechanical layout of the drive train later on.

**Mechanically recording the torque**

The stator of the E-machine is on rotating bearings. The bearings, e.g. ball bearings have an important role to play with regard to achievable accuracy. They largely determine the hysteresis of the torque measurement and thus make an important contribution to the accuracy of the overall system.

Depending on the size and weight of the stator, 1 or 2 bearings will be used for each bearing point. In order to increase the lifespan of the bearing and to prevent the balls marking the bearing bushes, the bearings are pre-tensioned. This is done by a ring that is pre-tensioned with cup springs and pressed onto one half of the bearing bushes, with the second half of the bearing bushes being fixed to a limit stop. This means that there is no play in the bearings, even if force is applied from outside.

A further variant of the pendulum bearing worth mentioning is the use of hydrostatic bearings. Using these low-friction bearings produces virtually hysteresis-free torque acquisition. The APA from AVL, for example, is implemented on one side with a hydrostatic fixed bearing and on the other as a movable bearing, which means that axial freedom from hysteresis can be ensured as well.

The disadvantage lies in the greater mechanical expenditure of the oil system. A considerable advantage of the bearings is that they are low-maintenance and there is very little wear, as movement is over a "triple-glide" (metal – lubricating film – metal) and there is therefore no direct contact with the metal.

The following components are available to convert the air gap moment operating at the stator to an electrical signal:

- Pendulum stator
- Pendulum pier
- Transverse beam – load cell
- Mechanical damper

This design of pendulum pier guarantees a connection from the stator with movable bearings to the rigidly mounted transverse beam [A] that is free from play and can be adjusted in parallel.

The compressive force is transferred by a compression bar [C] run on bearings in spherical saucers [B] and pre-tensioned with cup springs [E] and the tensile force by fishplates [D]. The pre-tensioning force of the cup springs must be at least as great as the maximum force that will occur during operation, caused by the air gap moment and including a certain safety reserve. Spherical saucers and a rounded compression bar always guarantee that the force is introduced on the load cell horizontally. The radius of the curvature on the pressure bar must be less than the radius of the curvature in the saucer, which gives a point-shaped bearing point. The load cell has a measuring spring made of highly tempered steel as a measuring element. The measuring spring is designed as a double transverse bar.

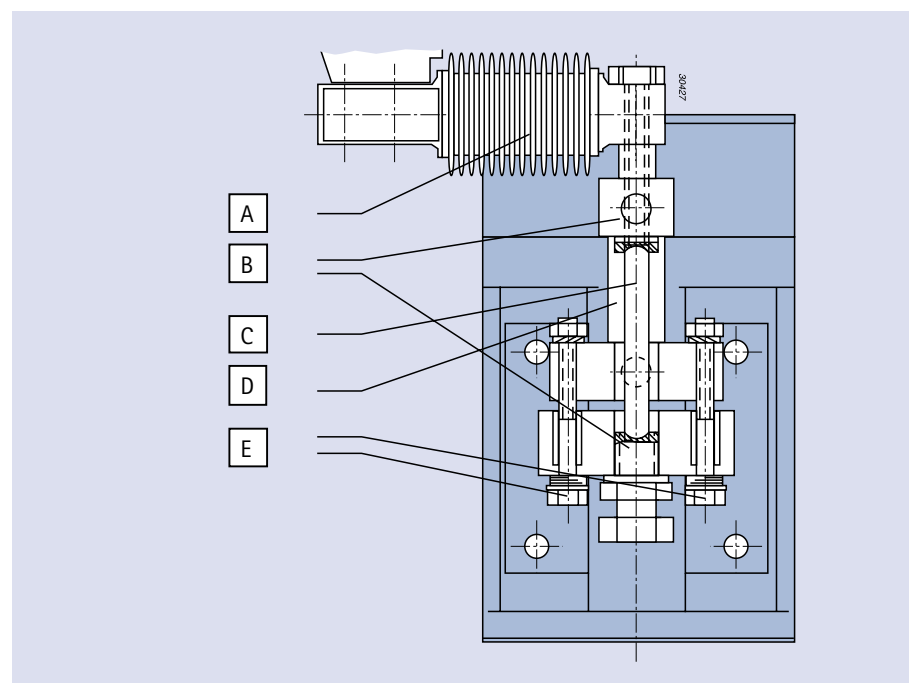

Fig. 2: Mechanical construction with measurement option in the direction of compression and tension, as well as compensation for a certain sideways displacement

The integrated piston-type damper filled with oil in coordinated viscosity already exerts a good damping effect on the force acting mechanically on the transverse beam. This means that even the raw signal is easily reusable for machine control without the need for additional electrical filtering.

In particular, if you take into consideration the principle of operation of an internal combustion engine and its intermittent torque characteristic (for details, also see Page. 9), system-intrinsic mechanical damping is a big advantage.

But the class accuracy of the transverse beam and the mechanical construction of the pendulum pier alone do not decide the accuracy of the entire measurement system, the accuracy class of the evaluation electronics is also involved.

Additional factors that affect the accuracy of measurement include:

- The stator cable connection
- Friction in the pendulum bearings
- The flow of air through the external ventilation system
- The cardan shaft or coupling between the test piece and the brake

These influences can be prevented by taking the appropriate measures:

- highly flexible power lines
- suitable choice of bearing
- parallel symmetrical airflow

### Electrical torque acquisition (computation)

Torque computation (generally known as the torque computer) is no longer a particular problem nowadays thanks to the availability of fast signal processors.

APA's torque computer is based on a machine operating map. Speed and current are measured and the magnetic flow calculated from them. The air gap moment is calculated by means of vector multiplication of the magnetic flow with a few kHz. The accuracy of the calculated moment is 3-5%. The part of the air gap moment that accelerates the inertia mass of the rotor, is calculated by using the differential value of the speed (dn/dt), multiplied by the known moment of inertia of the rotating parts. The shaft moment is available on the computer in its 2 individual components, electrical moment = air gap moment and acceleration moment. The sum of these two moments corresponds to the moment at the flange of the rotor.

Consequently, either the air gap moment or the shaft moment can be fed to the control unit as the actual value. The disadvantage of the calculated shaft moment lies in the high noise content of the signal; this is caused by the computation of the speed differential value using a small time unit dt. A good compromise must be reached here between the demand for fast control, which needs a correspondingly fast actual signal and a reasonable noise content. The air gap moment can now be controlled by the current and as a further consequence, the air gap moment can control the shaft moment.

If, for example, you make clear a gear change in the vehicle, you will quickly realize how fast the shaft moment control must be to generate realistic conditions for the engine. In the simulated decoupled state, the entire mass of the load unit must be controlled to 0 moment on the engine disk flywheel that is to say shaft moment = 0N•m, so it is important for the shaft moment to be measured or calculated very quickly and then for processing to continue. The processor of the APA E-machine control electronics calculates the air gap moment at 4,000Hz and thus forms a good basis for control and simulation.

### Bringing together the advantages of computation and measurement

Neither mechanical measurement nor computation alone are enough to meet the demands on a modern dynamic engine test stand. To benefit from the advantages of both signals in one system, the APA brings together the differently acquired measured values.

The electrically measured air gap moment that has great accuracy but little dynamic response, is returned to the control electronics. The highly dynamic, but more inaccurate, calculated moment is already available in the control electronics. Both moments, the calcu-

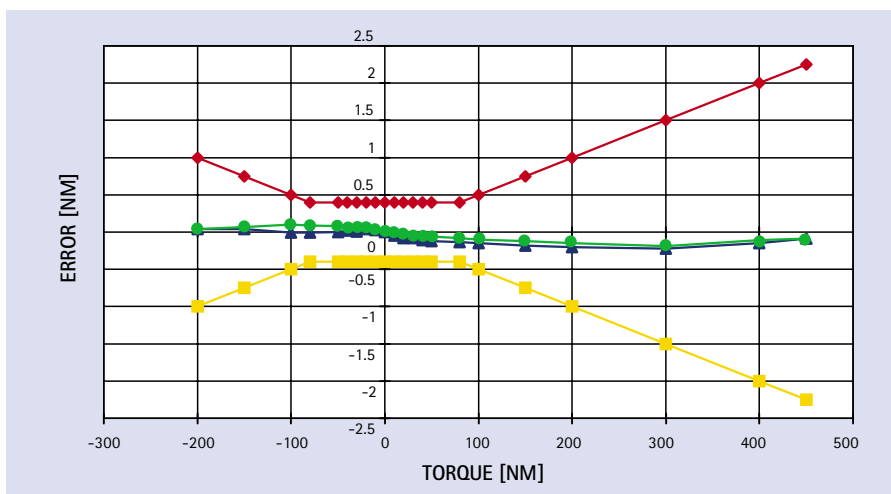

Fig. 3: This shows the typical calibration curve with the hysteresis characteristic of an APA with hydrostatic bearings

lated electrical moment and the air gap moment measured by the transverse beam are each fed to the processor over the same digital filter, as a digital value. The program compares the two values and, on the basis of the differential value, adjusts correction values in the machine model in order to make the calculated moment agree with the measured moment.

Continual correction gives great accuracy, even for dynamic operations. The machine can therefore be used as a fast torque actuator in a control circuit. As a further consequence, this can realize fast shaft moment control. This now ensures that even dynamic operations, for example, simulating the gear change for manually operated gearboxes, can be imitated realistically and with great accuracy.

## Measuring torque by means of a torque measuring flange - or shaft

### Drive train design

Unlike the measurement method described above, in this case, torque moment acquisition uses a torque flange or transducer shaft as an integral component of the drive train.

The working characteristic of the test piece (combustion engine) and the working characteristics of the load unit (e.g. APA) show the constraints for the layout of a drive train. If you make clear the working principle of an internal combustion engine, you quickly become aware that as well as the nominal values recorded in the working characteristics, there are other parameters that are relevant.

Firstly, because of the intermittent force deployment, you need appropriate peak values, caused by the discharge in the individual cylinders, in order to obtain the desired nominal output torque in the end effect. This effect is dominant, especially in the case of engines

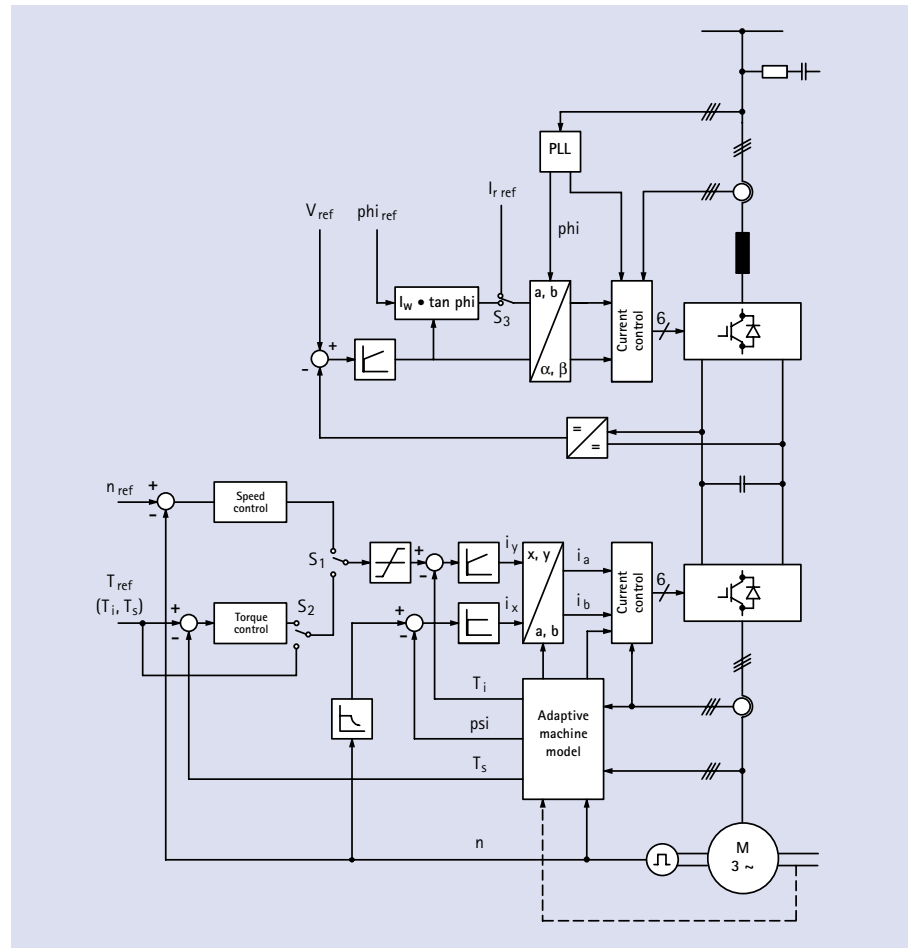

Fig. 4: Basic structure of machine control with integrated torque computer and returned measured moment

with only a few cylinders and should be taken into consideration both in the design of the drive trains and in the selection of torque measurement systems. Secondly, the internal combustion engine that generates excellent exciter functions because of its periodic principle of operation, gives the engineer designing the drive trains a not insoluble but demanding task, regarding resonance behavior.

### Theoretical background

#### The force flow in the internal combustion engine

As the transducer shaft is directly exposed to the moment existing in the drive train, with this measurement principle, you must keep a

close eye on the principle of operation of the internal combustion engine. The non-continuous principle of operation leads to irregularities in force deployment and as a further consequence, to varying torque. These irregularities depend heavily on the number of cylinders and when taken into consideration, lead to correction factors which in turn, together with the nominal values, produce new base values for the design.

Depending on the combustion process (diesel or Otto) and on the working process, it is possible to clearly define the force flow in the form of a function (see Fig. 6). This progression comes, on the one hand, from the gas discharges in the cylinder, and, on the other hand, from the mass that is rotating and



Fig. 5: T10F installed with damping element and flexible connection shaft

moving to and fro (inertia forces). With the help of Fourier analysis, the function can be divided into periodic functions, which as a further consequence indicate the exciting main harmonic order as well as the minor harmonic orders.

Finally, the interaction between the exciter function and the spring-mass system (rotating mass of the engine and of the drive train, with intermediary spring stiffnesses) produces the output functions that have resonance points. These resonance points are produced whenever periodically excited orders attain the resonant frequency (natural frequency) of the vibration system.

### Application-specific design of test stand drive trains in the fringe range

#### The single cylinder engine test stand

A single cylinder test stand presents a rather special difficulty. Firstly, because of the presence of a single cylinder that has to produce all the torque, the irregularities are far greater than with engines having more than one cylinder, and secondly, the vibration behavior, taking into consideration the exciter function coming from a single cylinder engine, poses a problem because of the "order behavior" that

comes with a single cylinder engine.

What does this mean from a machine dynamics point of view. A vibration system comprises a number of parameters that are recorded in the following motion equation in matrix form:

$$I \ddot{\varphi} + C \dot{\varphi} + D \varphi = P(\varphi)$$

These parameters include:

- I = Mass inertia matrix
- C = Spring stiffness matrix
- D = Damping matrix
- $\varphi$  = Phi (angle of rotation)

$\varphi$  in this case shows the variable quantity and  $P(\varphi)$  is the exciter function.

Basically, there are two possible ways to design a vibration system comprising rotating masses with intermediary stiffnesses. The first way is a supercritical design, as shown in Fig. 7.

The advantages of the supercritical design are that the resonance points, caused by the main harmonic components, are put below the operating range. This means that all the resonance points caused by minor harmonic components are inevitably below the operating range. In this context, you must take into consideration that the engine orders which, as described initially, come from Fourier analyses, are crucially influenced by the design of engine and the working process of the engine.

A vibration system can be low-frequency tuned, by high mass moments of inertia or by low stiffnesses between the masses, for example. In the case of the one cylinder test stand, this would mean that because of the exciting engine orders, the selected moments of mass inertia of the test piece or of the test

stand drive train will have to be exceptionally high, or the stiffnesses will have to be set exceptionally low.

However, this is often not possible for two different reasons. Firstly, you will run into design limits, and secondly, it can happen that the component loading runs into their limits. This means that it is not always possible to use the requisite flexibility in the form of an elastic element, if you take into consideration the peak torque, that can arise because of the irregularity, as the loading capacity is inversely proportionate to the flexibility. As a further consequence, this will mean that a supercritical drive train design is not always possible.

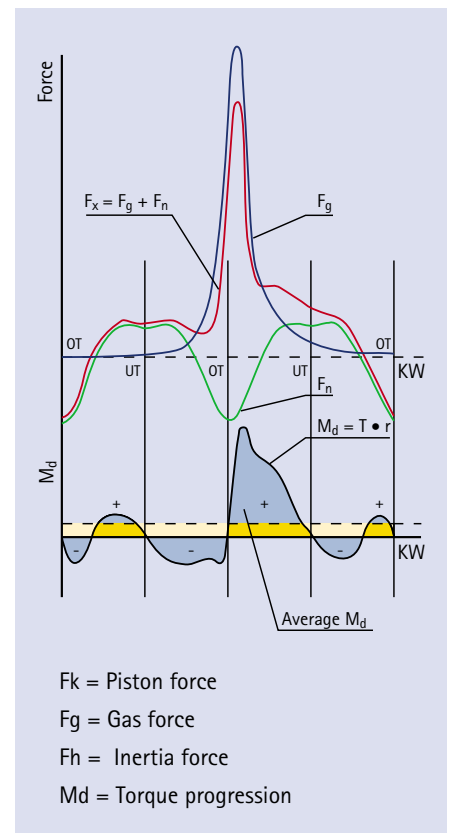

Fig. 6: The engine transmission forces of a combustion engine and the resultant torque progression

The second way represents the subcritical drive train design (see Fig.8). This tries to move the main harmonic components over the operating range with sufficient safety. At a first glance, this seems to be a pragmatic solution for a single cylinder test stand that can be implemented without risk. However, as far as selection of the stiffness values of the train is concerned, these will have to be very high to be able to implement the requirement described above. This can lead firstly to undamped loads arising for the train and for the engine.

Secondly, it will not be possible to banish high minor harmonic orders from the speed range, which can be a problem in the case of the single cylinder engine, as the higher orders can be very powerful. From this brief analysis of the problem, you can already see that in the case of a single cylinder test stand, the task is not easily resolved, and even if it can be, feasible realization will only be possible by using proven design tools. AVL, as a development and research laboratory for combustion engines also has available some software tools that have been developed in-house specifically for the design of engine components, such as crankshafts.

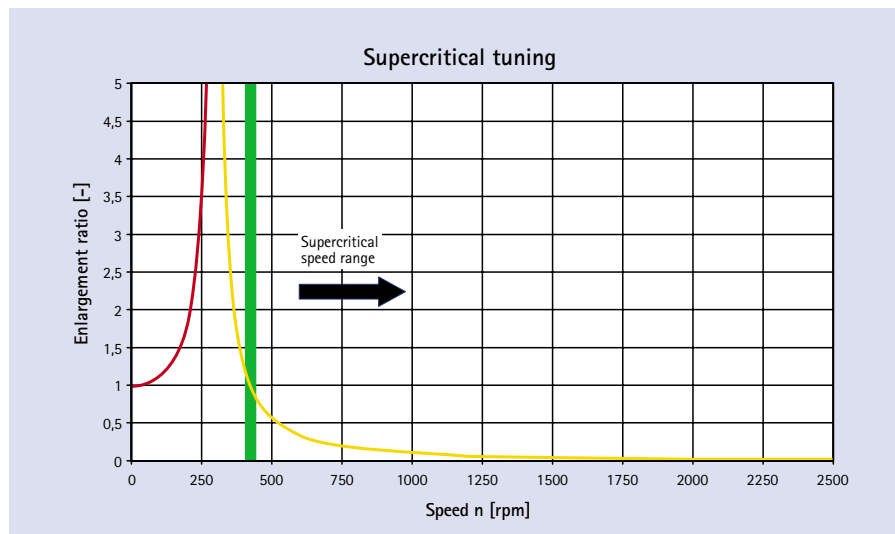

Fig. 7: Operating range for the supercritical design

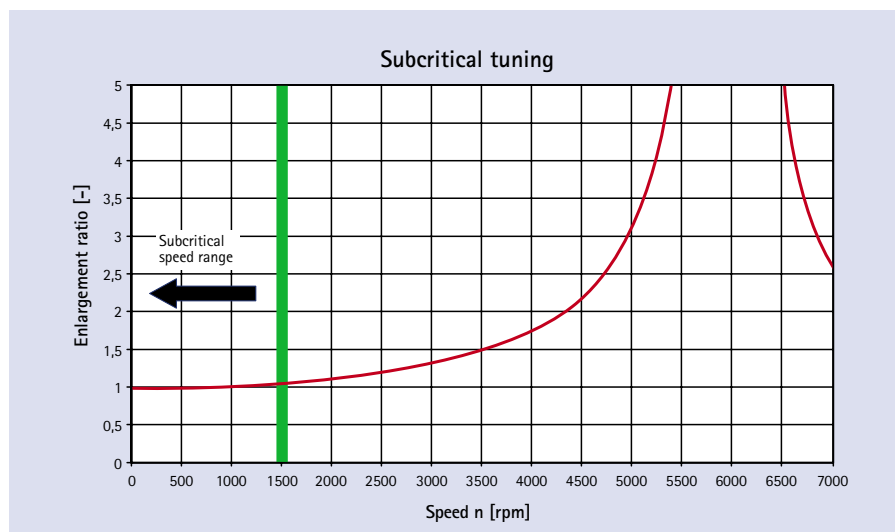

Fig. 8: Operating range for the subcritical design

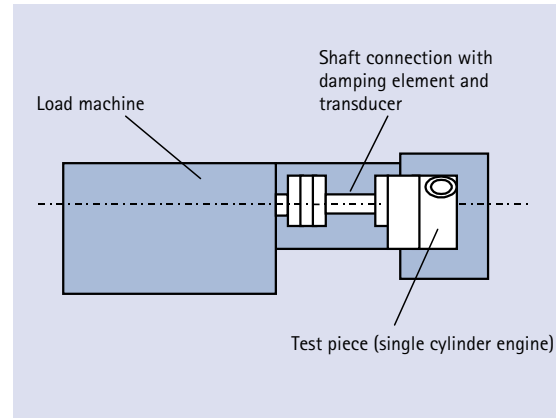

Fig. 9: Single cylinder test stand layout using the T10F-SVL torque flange

These tools serve to speed up the development of engine components. A typical software tool is AVL-BRICKS, that allows you to examine systems of vibration. This system works in the frequency range and allows the most varied evaluations. Thus, for example, you can calculate and display, to start with the angular variations in the various sections of the vibration systems, then the torque amplitudes and finally the stress characteristics that result from the relative torsions of the system components.

In the past, this software tool could have been used many times in test stand engineering for the proper and timely design of drive trains for ambitious test stand projects, such as a single cylinder test stand usually is. By using AVL-BRICKS it is possible to undertake, within an acceptable timeframe, the simulation of a test stand with the accompanying test piece. To go right back to the single cylinder test stand, Fig.9 shows the design of this type of test stand in diagram form.

In order to be able to properly design the drive train using AVL-BRICKS, you should think back to Fig. 7 and Fig.8 and the layout of a single cylinder test stand shown there. Varying the test stand parameters by systematically varying the mass moments of inertia and the stiffness values in the permissible ranges, often leads to the conclusion that it is not possible to keep all the resonance points out of the operating range.

This means that you have to work with damping elements, in order to keep the amplitudes caused by resonances in the operating range as low as possible. In this case, the reactive power caused by the resonance phenomena is converted to dissipation energy. Designs of this type are only possible, however, if, as a further consequence, the dissipated energy is detected and the lifespan of the parts under stress is

determined by load collectives. Fig. 10 and Fig. 11 show the simulation results that led to designing a single cylinder test stand drive train with a special damping element.

As you can see from these illustrations, the resonance point is at approx. 1,700 rpm and is caused by engine order 0.5, that at this speed attains the 1st inherent mode of the system.

This design is possible mainly because of the fact that the test stand in question is a steady state test stand, at which measuring points are predominantly approached in a steady state.

The resonance point is run through in a reasonable period of time, so that the dissipation energy does not lead to any significant loss of lifespan in the damping components.

In this way, it is possible to determine the moment characteristics relatively accurately within certain limits by simulation. As well as a suitable choice of components, this also allows you to choose a torque measurement system that is not overdimensioned and thus does not lead to a loss of accuracy.

### The racing test stand

The racing test stand is a further extreme example. There is surely no other area of engineering in which the search for new limits is as pronounced as it is here. In order to set the limits discussed above higher still, limit values must be reproducible and detectable. To do this, you will always need a new development, predominantly on the measuring side and also on the simulation option side. Because of the smooth interplay between electronics and mechanics, it is desirable for this new development to also be on the mechanical side.

This aspiration has brought a response from AVL and, as already mentioned at the start, increasingly highly-dynamic test stands are being built, to allow simulations to be implemented that come ever closer to the real vehicle. Fig. 12 contains a diagram of a highly dynamic racing test stand.

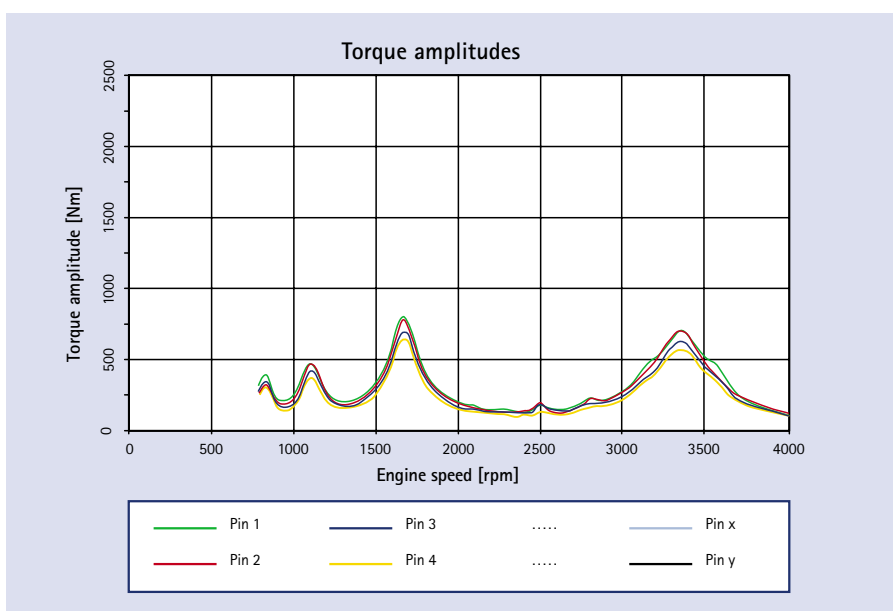

Fig. 10: Torque amplitudes in the individual sections of the drive train. The measurement system is in the range identified by pin 3

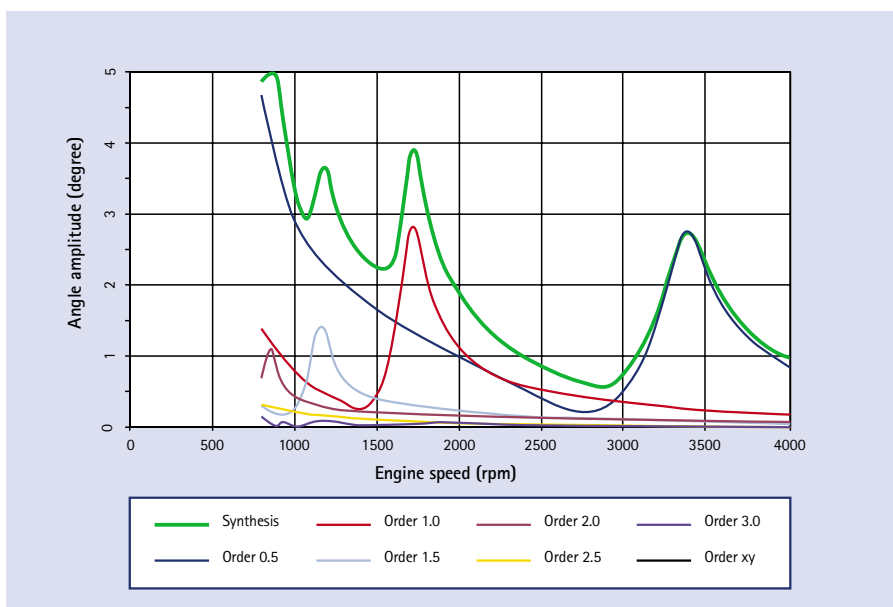

Fig. 11: Angle amplitudes of the individual engine orders in the measurement system range

Compared to the single cylinder test stand described in Fig. 7, in this case you are dealing with a vastly more complex system, with many branches. The basic components include load machines, summator gear trains and an intermediate bearing unit. Because of the large number of system components, it is now possible to use the analysis of a multi-mass vibration system to better tackle the design of the test stand drive train.

It is sensible to use AVL-Bricks again as the tool to design the vibration system. An additional fact, that makes it difficult to tune the vibration system, is the requisite maximum speed that does not allow you to integrate elastic components into the test stand train.

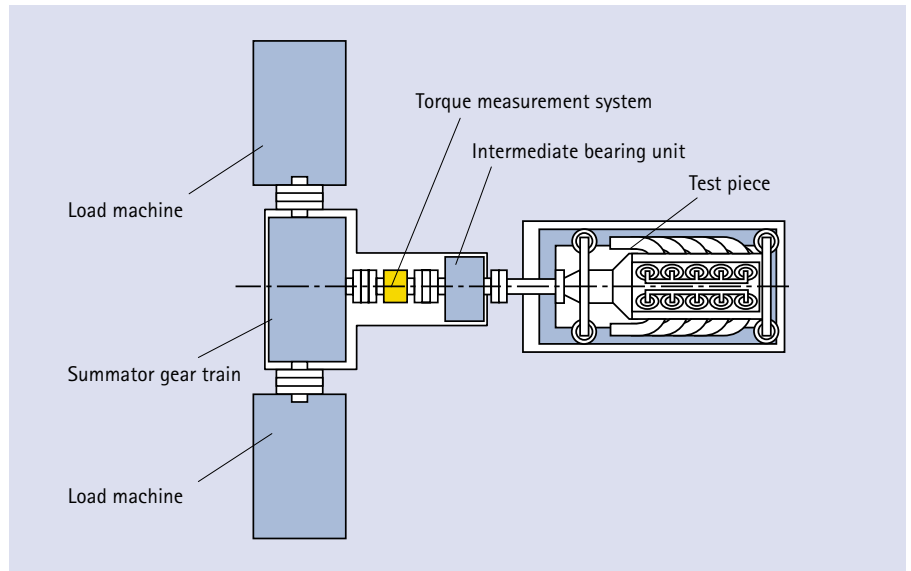

Fig. 12: Typical highly-dynamic racing test stand

If you now include the test piece in the consideration, and as a further consequence, the excitation coming from the test piece or the racing engine, you can assume that this factor will not make the design process any easier. As racing engines are, without exception V-type engines, corresponding exciter functions are produced, that show uneven orders, starting with order 0.5. Together with the fac-

tors mentioned above, such as the multi-mass vibration system and the operating speed band, this means that resonances can never be moved completely out of the operating range.

Since it is also not possible to use a damping, elastic element on the fast-turning side, it requires a rather special skill to choose the

correct train component stiffnesses and all the mass moments of inertia. Fig. 13 shows the computation results produced in accordance with the design of a racing test stand train. The diagram shows some clear resonance points, whose analyses would go beyond the framework of this report, which is why we cannot go into any further detail.

As well as the important task of designing components that are suitable for stress, in this application it is important to make sure that when using the measurement system, it is dimensioned in such a way as to produce maximum accuracy and reproducibility of measured values. This is the only way in which it will be possible to detect limits and by research and development, push them into higher ranges.

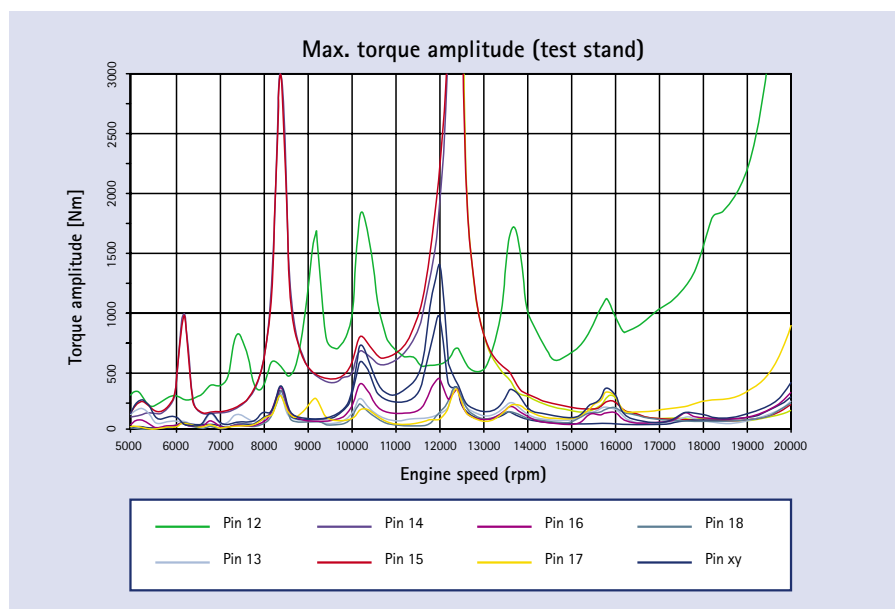

Fig. 13: Moment amplitudes in some sections of the drive train. The transducer shaft is arranged in position 16

## Summary

In conclusion, we briefly outline the advantages and disadvantages of the two different systems of measurement:

### Torque measurement by means of pendulum bearings

#### Advantages:

- Highly accurate acquisition of torque in steady-state operation
- Can be recalibrated when rotating (in operation), important for checking accuracy in operation
- Signal quality without additional or with little filtering is good for reuse, as good mechanical damping already available
- Little effect on principle of operation and process
- Measurement not dependent on speed
- Measuring range of the measurement system only has to be slightly greater than the nominal moment of the test piece

#### Disadvantages:

- Limited usability for dynamic applications because of the lack of shaft moment, as the drive inertia mass is contained in the signal
- The signal is afflicted with hysteresis governed by the principle of pendulum bearings

### Measuring torque by means of a transducer shaft or flange

#### Advantages:

- Measured value contains all the portions of the moment that have an effect in the drive train, steady state and dynamic (accelerating torque) torque
- Use of standard load machines
- With a machine, gear train, test piece arrangement, the moment can be measured where required by the application

#### Disadvantages:

- More expenditure required in drive train design, in particular for applications in the fringe area
- Signal with high proportion of signal outside the useful signal because of combustion shocks, irregularities because of cardan joint, resulting in overdimensioning of the measurement system
- No calibration checking possible in rotary operation
- Measurement is speed-dependent or limited by the maximum speed of the transducer shaft
- Internal combustion engine principle of operation has a great effect

Both methods of measurement are equally legitimate and have their own areas of operation:

A highly dynamic pendulum machine like the APA has its main area of application in the classic development test stand. The spectrum that can be covered by a test stand ranges from measurement of friction to steady state performance measurement or dynamic ECU optimization to dynamic exhaust gas analysis cycles.

The application for conventional machines with a transducer shaft is in the powerpack or drive train test stand, for example, as because of the transducer shaft, torque in the drive train can be acquired in-phase. The conventional machine is used on the engine test stand, where the test requirements are not as diverse as those on the development test stand.

As well as the basic measured value acquisition options, the report shows the advantages that arise from a simulation and how they can be implemented in practice. Further development and the increased use of simulation tools can reduce development times and simultaneously allow optimization to increase the accuracy of the measurement to be carried out and implemented.