



ram reports in applied measurement

Experimental analysis of mechanical stress in passive reinforcement anchorages in C-C-T nodes

C. Castro, P. Miguel,
M. A. Fernández, J. R. Martí,
Polytechnic University
of Valencia, Spain

Summary

The article presents a new test for analyzing the mechanical stress of adhesion anchors in C-C-T nodes. The primary aim of the investigation is to develop a practical design standard which, in the form of a dimensioning program, can be used to define important parameters for reinforcement anchorages. As well as the various concrete qualities and bar diameters, the parameters used in the program include the adhesion length and the angle of inclination of the tie bar. Described below are the construction and instrumentation of the test piece, the test setup, the way in which the experiments were performed and the results.

Introduction

When designing concrete structures, the precise dimensioning of the anchorages is a difficult problem, that can only be solved on the basis of experimental and theoretical investigations. Important aspects of this problem are dealt with in reference items [1]–[14]. Of particular significance is the interpretation of the geometric dimensions such as the length of the anchorage in elements such as brackets, moldings or structural elements supported by girders. The strength of adhesion depends not only on the length of the anchorage, but also the

compression parameters of the concrete. High transverse compressions (perpendicular to the reinforcement bar) vastly improve the strength properties, thus allowing the length of the anchorage to be reduced. To quantify this correlation, a new test was developed which allows the adhesion forces of CCT nodes (compression-compression-tension joints) to be analyzed and the application of tensile stress to the reinforcement bar to be recorded metrologically. A distinction is made between the load amounts transmitted to the transverse compression area of the concrete and those diverted into the reinforcement bar of the anchorage. The aim of the investigation is the development and experimental support of a dimensioning program that allows the construction engineer to specify reinforcement anchors in CCT nodes. The available parameters in this program are the concrete quality, the diameter of the reinforcement bar, the application length at the reinforcement bar (adhesion length) and the angle of inclination of the bar axis to the flow of force. To determine the transmission of force to the reinforcement bar, the investigation looks at the distribution of force to the concrete structural element and the bar, when the force is introduced obliquely into the bond. The diagram in **Figure 1** clarifies the flow of force in the concrete.

Experimental analysis of mechanical stress in passive reinforcement anchorages in C-C-T nodes
 C. Castro, P. Miguel, M. A. Fernández, J. R. Martí, Polytechnic University of Valencia, Spain

The horizontal component of force C applied obliquely under angle θ is split into amount T_1 (transmitted by the joint) and amount T_2 (absorbed by the anchor). The vertical component is supported as amount R by the lower bearing.

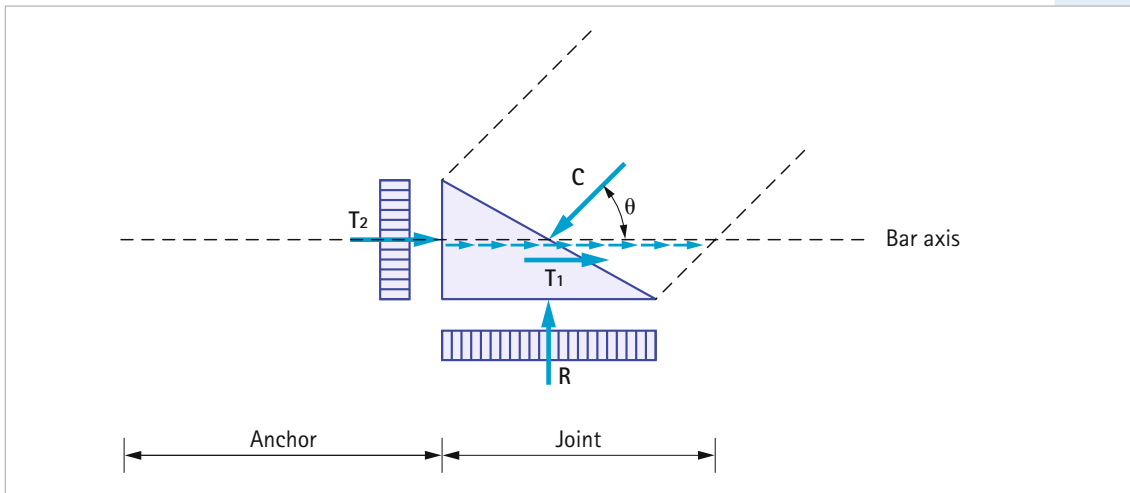

Fig. 1:
 Diagrammatic
 view of force
 distribution in
 concrete

The total bar force, produced from the force equilibrium in the horizontal direction, is

$$T = T_1 + T_2 = C \cdot \cos \theta \quad (1)$$

with amount T_1 , as shown in Figure 2, being applied gradually to the bar over the length of the joint.

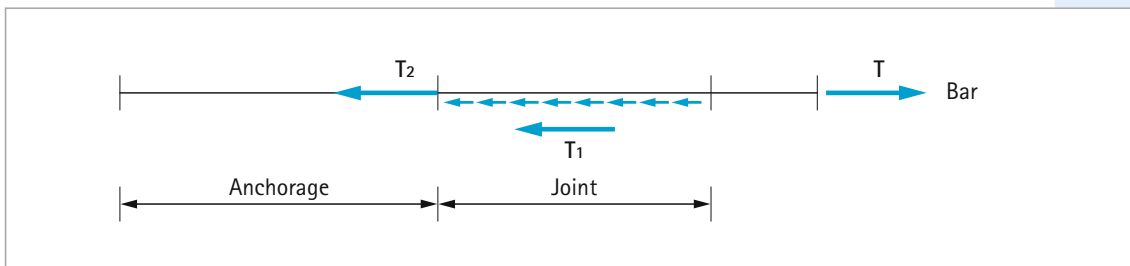

Fig. 2:
 Diagrammatic
 view of the
 longitudinal force
 response in the
 reinforcement bar

Experimental analysis of mechanical stress in passive reinforcement anchorages in C-C-T nodes

C. Castro, P. Miguel, M. A. Fernández, J. R. Martí, Polytechnic University of Valencia, Spain

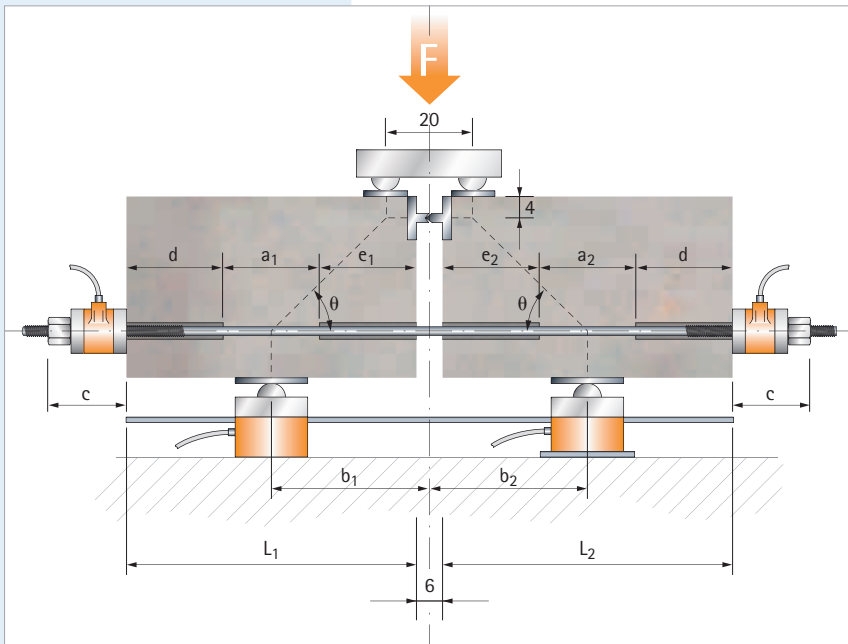

Fig. 3:
Test piece with loading

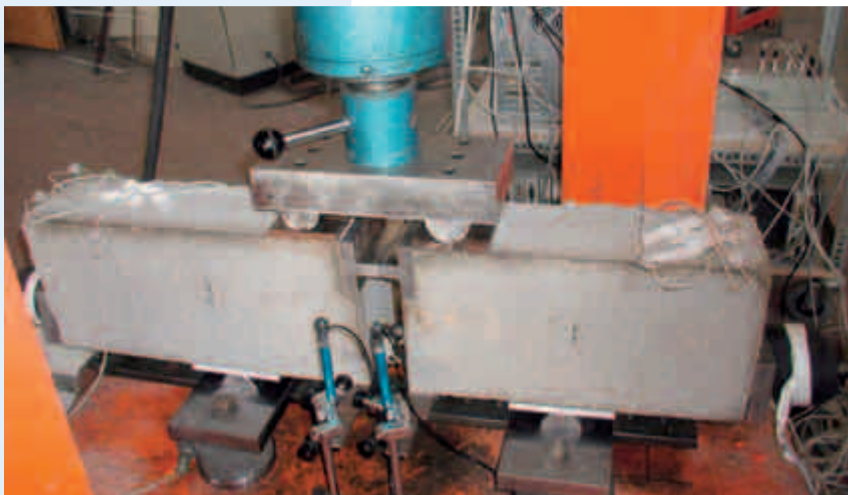

Fig. 4:
Test piece with
loading device

Test facility

The experimental implementation of the stress ratios presented in Figure 1 is achieved by using a concrete test piece that is split in two, with both the parts connected by a reinforcement bar with a solid reinforcement anchorage (Fig. 3).

While the cross-sectional measurements are fixed, with a width of 15 cm and a height of 24 cm, various dimensions such as the adhesion lengths, a_1 and a_2 , are variable, so that tests can be run with different parameters, such as the angles of inclination. The solid joint between the reinforcement bar and the concrete is only made in the exactly prescribed areas in both the parts. In areas d and e , adhesion is prevented by inserting PVC sleeves. The reinforcement bar is anchored at the outside ends of the blocks, by a nut and a washer in each case. Force transducers are fitted here to measure the residual anchoring force (Fig. 5). Steel elements are added in the upper block area to transmit the compressive forces that arise between the blocks when under load. These implement a flexible joint with sharp edges and fins.

To perform the test, this test piece is fitted into a hydraulic load frame (1,000 kN), where it is supported underneath on two free-moving rollers lubricated with MoS₂ graphite mounting paste. At the top, total force F is distributed by a bridge and is introduced to the test piece also via cylindrical rollers. All the force application points to the concrete are strengthened by inserting steel plates. Figure 4 shows the test piece fitted into the load frame.

Experimental analysis of mechanical stress in passive reinforcement anchorages in C-C-T nodes

C. Castro, P. Miguel, M. A. Fernández, J. R. Martí, Polytechnic University of Valencia, Spain

Receiving and processing measured values

During the continuous loading of the sample generated by the hydraulic test machine, the following mechanical quantities are recorded metrologically.

1. Forces

- Total force of the hydraulic cylinder
- Bearing forces at the lower supports
- Anchoring forces at the side anchorages of the reinforcement bar.

Various HBM force transducers, such as the C6A (200 kN) and the C2 (100 kN) were used to measure force. As an example, Figure 5 shows the C6A force transducer (200 kN) that was used to measure the anchoring forces.

2. Strains

- Strains in three directions (rosette measurement) in the force flow area of the concrete blocks, with LY42-50/120 strain gages (HBM) (Fig. 6a, measuring points 1 to 6)
- Longitudinal strain in the center of the reinforcement bar, with LY41-3/120 strain gages (HBM), to determine bar force T (Fig. 6a, measuring points 7 and 8 and Fig. 7)

3. Displacements

- Opening of the central gap between the concrete blocks, with SLS190/50 displacement transducers (Penny+Giles) (Fig. 6a, measuring points 15 and 16)



Fig. 5: C6A 200 kN force transducer for measuring external anchoring forces

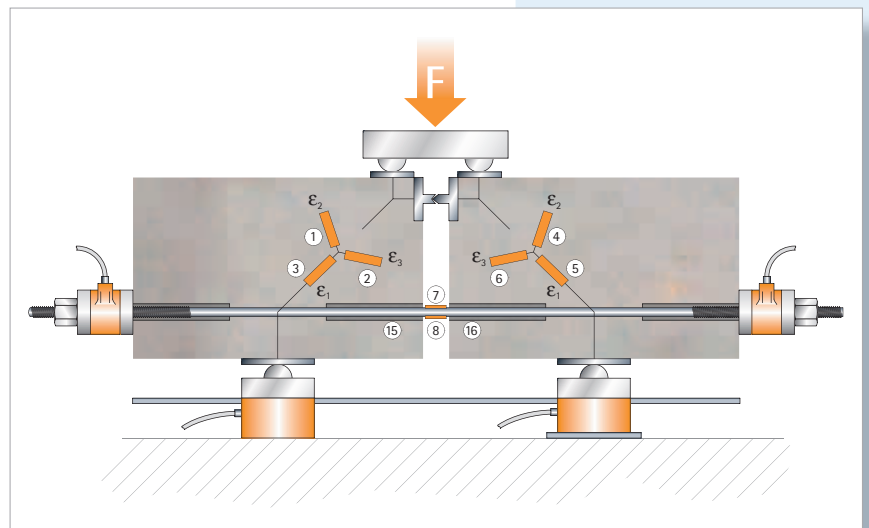

Fig. 6a: Position of the SGs and the displacement transducers: 1-6 LY42-50/120 SGs (HBM), 7-8 LY41-3/120 SGs (HBM), 15-16 displacement transducers



Fig. 6b: View of the complete installation

Experimental analysis of mechanical stress in passive reinforcement anchorages in C-C-T nodes
 C. Castro, P. Miguel, M. A. Fernández, J. R. Martí, Polytechnic University of Valencia, Spain

Fig. 7:
 LY41-3/120
 SGs (HBM) for
 measuring total
 bar force T



Fig. 8:
 Display of
 measured
 values in real
 time during the
 test run

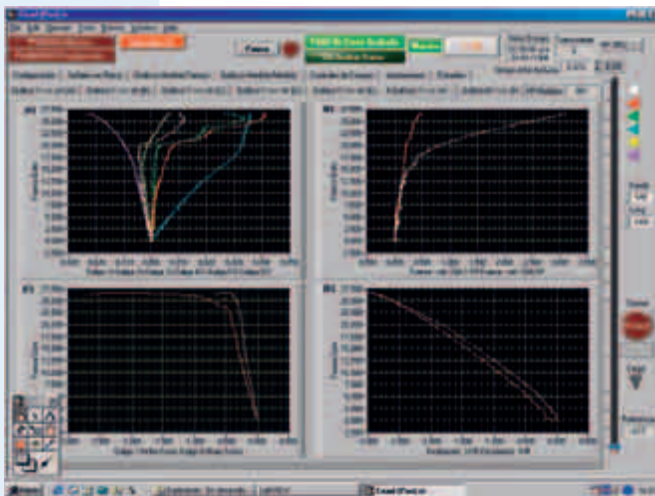

A software package program developed at the Civil Engineering Institute of the Polytechnic University of Valencia was used for automatic control of the test machine and to record, visualize and store all the data in real time. Figure 8 shows the real-time presentation of the measured values during a test run. All the measured values are represented as a function of the total force. The details are as follows: top left are the strain values of measuring points 1 - 6; bottom left is the total bar force, calculated from the strain values of measuring points 7 and 8; top right are the anchoring forces at the external fastening points and bottom right are the displacements at measuring points 15 and 16.

Test program and results

A total of 81 instrumented test pieces were tested in the described test facility. The tests differed with regard to concrete quality, execution and inclination of the reinforcement anchor and adhesion length. The test parameters are listed in Table 1.

The parameters were used as the name to uniquely identify the sample and the test. Thus, for example, (V-25/16/45/10-25) means concrete strength 25MPa, bar diameter 16mm, angle of inclination 45° and adhesion lengths 10cm on the left and 25cm on the right side of the test piece. The correlation measured at this test piece

Tab. 1:
 Parameters of
 the test pieces
 used

Parameters	Value		
Concrete quality (compressive strength in MPa)	25	50	80
Diameter of the reinforcement anchor in mm	12	16	20
Angle of inclination of the anchor to the flow of force in °	27	45	63
Adhesion length (left to right) in cm	5 - 20	15 - 15	10 - 25

Experimental analysis of mechanical stress in passive reinforcement anchorages in C-C-T nodes
 C. Castro, P. Miguel, M. A. Fernández, J. R. Martí, Polytechnic University of Valencia, Spain

between the total tensile force T , measured in the tie bar and the anchoring force T_2 recorded at the external anchorage point is shown in the graph in Figure 9 (equation 1 and Fig. 2).

This clearly shows that with an adhesion length of $a = 10$ cm, the total force is transmitted virtually totally to the concrete block via the bond, up to a value of $T \approx 60$ kN, which corresponds to a longitudinal stress of $\sigma = 300$ MPa. The external residual anchoring force stays very small, at $T_2 \approx 2$ kN in this initial area. There is then a more pronounced increase in T_2 and at $T \approx 100$ kN, a value of $T_2 \approx 13$ kN is reached. In this load range, adhesion subsides increasingly between 60 kN and 100 kN, with the maximum force that can be transmitted by the bond being $T_1 = T - T_2 = 87$ kN. Any further increase in load will lead to the failure of the tie bar. If the adhesion length is $a = 25$ cm, it is not possible to observe any subsidence in adhesion until $T \approx 100$ kN. The joint will also fail here if the maximum load in the tie bar is exceeded.

As well the failure of the tie bar as a result of exceeding the maximum endurable tensile stress, the tests made it possible to observe a further failure mechanism. This is a crack that divides the concrete solid vertically into two pieces, before the tie bar fails (Fig. 10).

In Figure 10, the area marked by (a) on the exposed tie bar is that in which a joint between the concrete and the tie bar is prevented by the PVC sleeves. The actual adhesion area is identified by (b) and (c) marks the SGs that were used to measure the total anchoring force T .

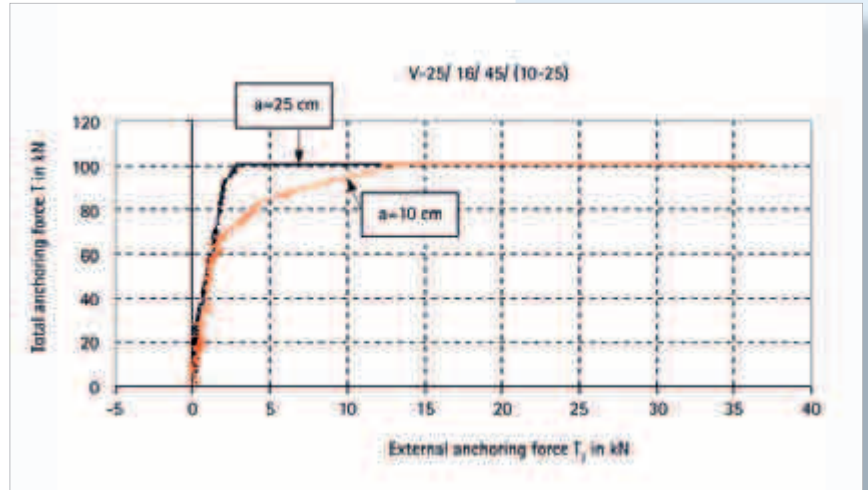

Fig. 9: Correlation between total anchoring force T and external anchoring force T_2 for adhesion lengths $a = 10$ cm and $a = 25$ cm

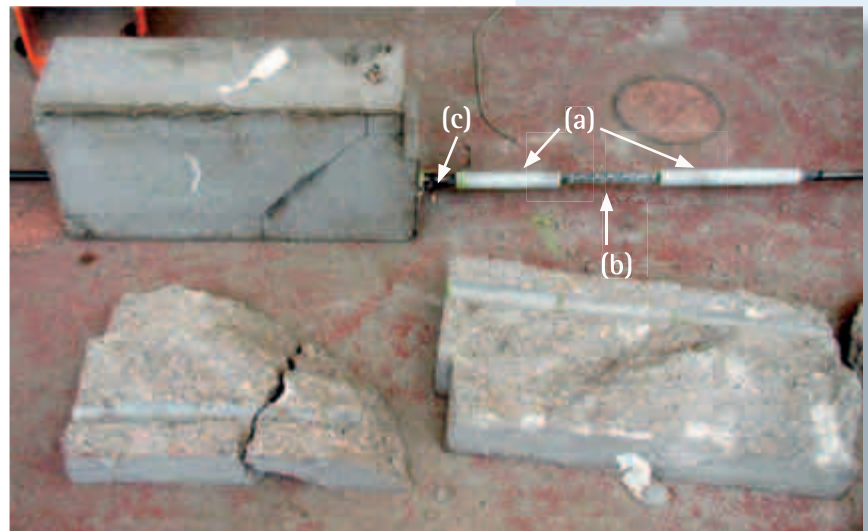

Fig. 10: Joint failure caused by cracks forming

Experimental analysis of mechanical stress in passive reinforcement anchorages in C-C-T nodes

C. Castro, P. Miguel, M. A. Fernández, J. R. Martí, Polytechnic University of Valencia, Spain

Conclusions

Compared to other, well-known tests, the test procedure described here has the advantage that the transverse load increases in proportion to the tensile force in the reinforcement bar, so that the angle of inclination between the forces remains constant while the load is increasing. This enables the stress simulated in the test to correspond very well to the actual ratios, as they occur in real life in the anchorages of girders, brackets or moldings. The idea of having a test piece that is split in two enables two tests to be carried out simultaneously with different parameters, with it always being possible to run the tests to their conclusion until failure, for both sides, even if the joint on one side gives way prematurely. In previous test implementations, the maximum load was limited both by the tie bar giving way and by cracks forming.

Because of the extensive instrumentation and the fact that the measured values are recorded in real time, the state of the joint can be watched continually. Because the strain gages are prepared at the outer surfaces of the concrete blocks in the force flow area, incipient cracks can be detected in good time by increasing the strain. The important strength properties of the joint can be assessed, with precise force measurement, especially of the force transmitted from the tie bar to the concrete block and thus the requisite adhesion length, making it possible to accurately determine the adhesion length.

References

- [1] ADEBAR P., KUCKMA D. and COLLINS M.: Strut-and-Tie Models for Design of Pile Caps: An Experimental Study, *ACI Structural Journal*. V. 87. No 1. Jan-Feb. 1990.
- [2] BRIAN S. MAXWELL, JOHN E. BREEN.: Experimental Evaluation of Strut-And-Tie Model Applied to Deep Beam with Opening, *ACI Structural Journal*, Jan-Feb, 2000.
- [3] Code Model. CEB-FIP 1990.
- [4] E.H.E. INSTRUCCIÓN DE HORMIGÓN ESTRUCTURAL, Ministerio de Fomento.
- [5] HONG S-G.: Truss Model for Tension Bars in Reinforced Concrete Beams: Tension-Tension-Compression Regions, *ACI Structural Journal*. V. 93. No 6. Nov-Dec. 1996.
- [6] HONG S-G.: Strut-and-Tie Models and Failure Mechanisms for Bar Development in Tension-Tension-Compression Nodal Zone, *ACI Structural Journal*. V. 97. No 1. Jan-Feb. 2000.
- [7] HONG S-G., MUELLER P.: Truss Model and Failure Mechanism for Bar Development In C-C-T Nodes, *ACI Structural Journal* V. 93. No. 5 Sept-Oct, 1996.
- [8] JOHANSSON M.: Nonlinear Finite-Element Analysis of Concrete Frame Corners, *Journal of Structural Engineering*. Jan-Feb. 2000.
- [9] LIANG Q.Q., XIE Y.M. and STEVEN G.P.: Optimal Topology Selection of Continuum Structures with Displacement Constraints, *Computers and Structures* 77. Pergamon 2000.
- [10] MARTÍNEZ, MARTÍNEZ, A.: Sistematización Numérica del Método Biela – Tirante, Final Project in E.T.S.I.C.C.P. of Valencia (Spain). Professor: Pedro F. Miguel Sosa. U.P.V.1998.
- [11] SCHLAICH J., SCHÄFER K, JENNEWEIN M.: Toward a Consistent Design of Structural Concrete, *PCI Journal*, V.32. No. 3, May-Jun, 1987.
- [12] SCHLAICH M., ANAGNOSTOU G.: Stress Fields for Nodes of Strut and Tie Models, *Journal of Structural Engineering*, Jan 1990.
- [13] SIAO W.B.: Shear Strength of Short Reinforced Concrete Walls, Corbels and Deep Beams, *ACI Structural Journal*. V. 91. No 2 Mar-Apr. 1994.
- [14] YUN Y.M. and RAMÍREZ J.A.: Strength of Struts and Nodes in Strut Tie Models, *Journal of Structural Engineering*. Vol 122. No. 1. 1996.