

Piezo sensors enable reliable measurement from the widest range down to the smallest sub-range

Dirk Möller, HBM Messtechnik GmbH

The piezoelectric effect is based on the fact that crystals generate an electric charge in response to mechanical stress. The applied force is absolutely proportional to the electric output signal/charge. This effect allows reliable measurement of process forces in industrial applications. The quartz measuring element functions as a mechatronic component, because the applied mechanical stress is converted into an electric output signal already in the quartz. Other measurement principles such as strain gage technology require an elastically deformable measuring body. The mechanical change in length is converted into an electric output signal by a deformation of the strain gage that is proportional to the load. The advantage of piezo technology is that the elastic deformation is so small that it can be neglected so that extremely stiff mechanical designs can be implemented. The deformation of the quartz amounts to only a few micrometers.

The relationship between applied force and generated charge is not dependent on the size or form of the piezo crystal, but only on the material used. The following relationship applies:

$$Q = q_{11} \cdot n \cdot F$$

n: Number of quartz elements connected in series

F: Mechanical stress/force

q_{11} : Material constant, e.g. -4.3pC/N

Q: Generated electric charge

Various measuring ranges are provided through different sizes of piezo sensors. The absolute electric sensitivity, however, is independent of the measuring range.

Comparison of the system with strain gage technology shows the significant difference between the electric sensitivities:

Example 1:

5kN piezo sensor => characteristic: -4.3pC/N

5 kN SG sensor => characteristic: 2mV/V => 0.4 μ V/N

Example 2:

140kN piezo sensor => characteristic: -4.3pC/N

140kN SG sensor => characteristic: 2mV/V => 0.014 μ V/N



Fig. 1: Piezo sensors of the CMC family

In general, the sensitivity of piezo sensors is independent of the measuring range. This fact provides the technological basis for precise and reliable measurement in a wide measuring range over several sub-ranges (decades). In practice, this means that 5 kN can be measured with a 140-kN sensor as precisely as with a 5-kN sensor.

Extremely **high overload capability** can be achieved without loss of accuracy which is essential, for example, when measuring small forces during inline control of switches or control elements. Here, small test forces (<20 N) need to be reliably and precisely controlled. When a machine crash occurs or sensors are installed, this nominal force can, however, be exceeded several times over. Thus a piezo sensor with 1 kN maximum capacity can be chosen for regular use with 0 – 20 N, for example, to

eliminate any possibility of overload. The advantages of the piezo solution are obvious: **reliable operation** can be guaranteed at **consistently high sensitivity**.

Another inherent advantage of piezoelectric measurement technology is that it enables the slightest variations to be **precisely and reliably** measured even at high base loads. The base load can very easily be "zeroed". The charge input just needs to be reset to cancel the output signal of the piezoelectric sensor, i.e. the charge shift. The advantage: Any effect of the base load signal is eliminated and thus a favorable ratio between wanted signal and base load is achieved. The result is enhanced signal quality.

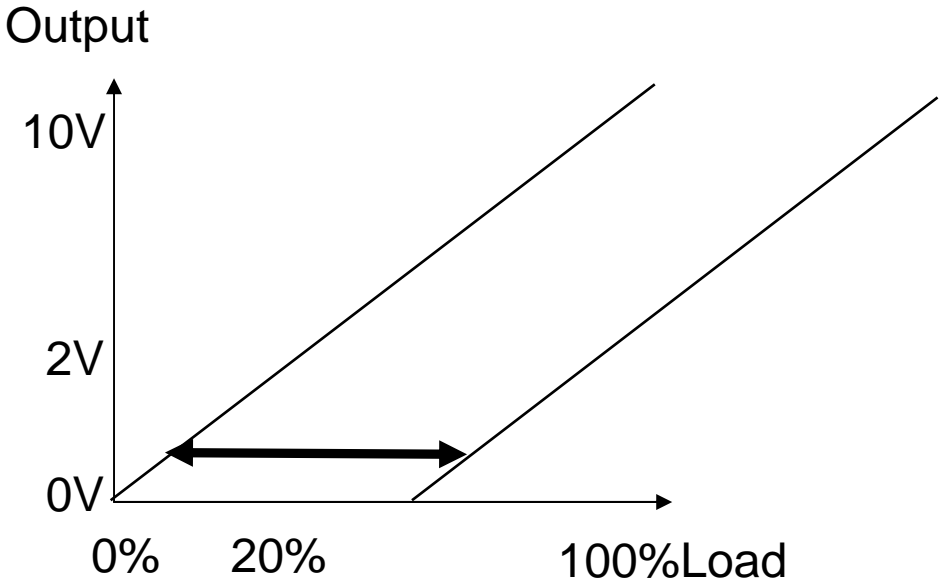

Fig. 2: Horizontal shift of the characteristic by reset of the charge input (piezo technology)

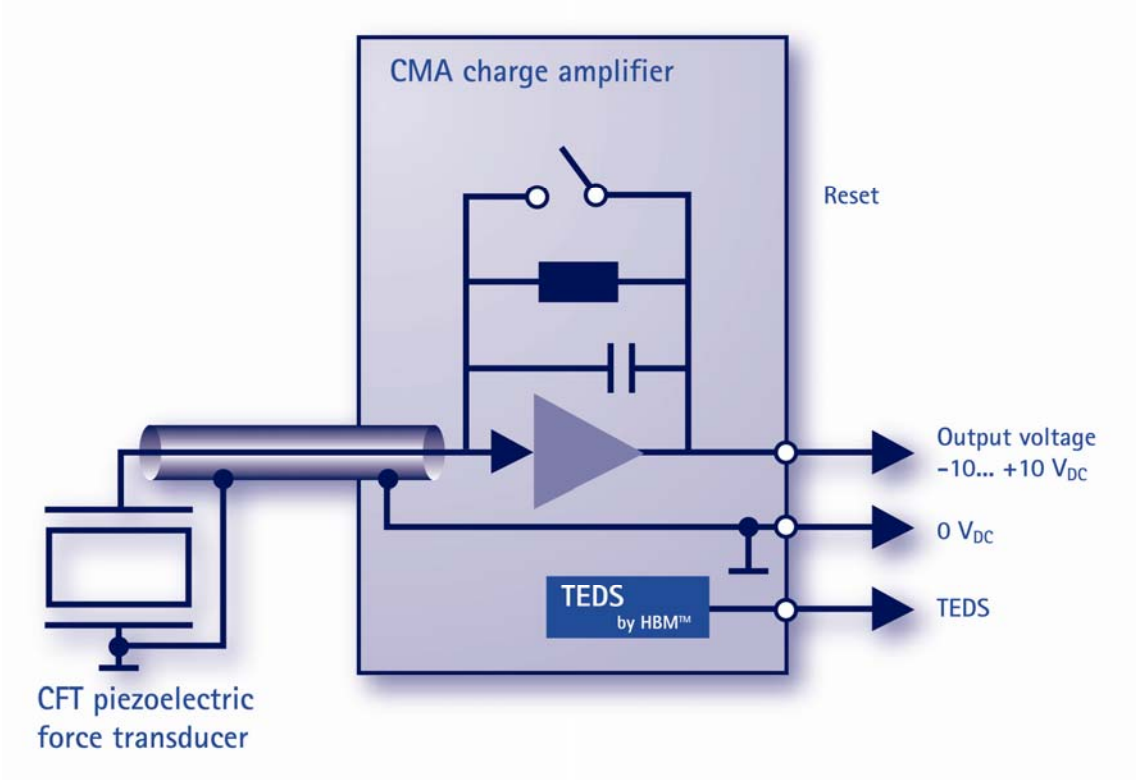

Fig. 3: Block diagram of charge amplifier with reset circuit

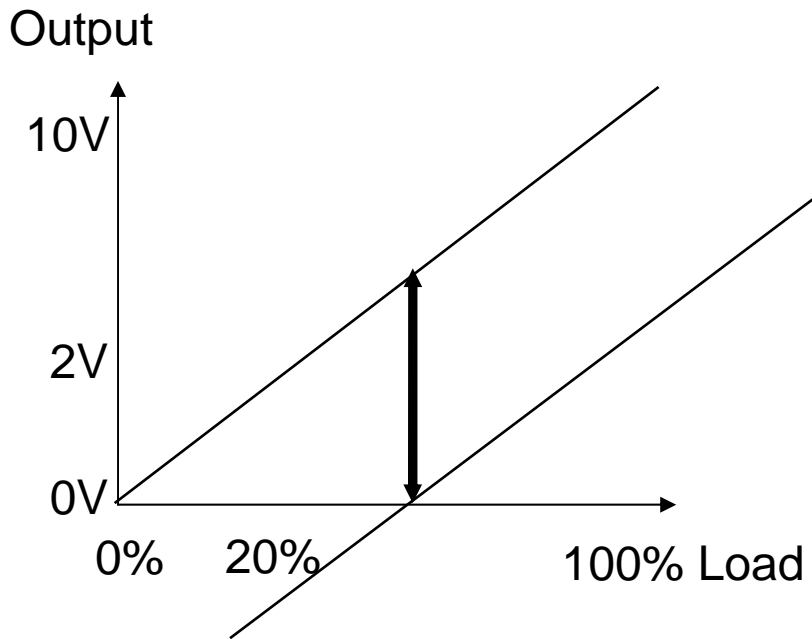

Fig. 4: Vertical shift of the characteristic by zeroing (strain gage technology)

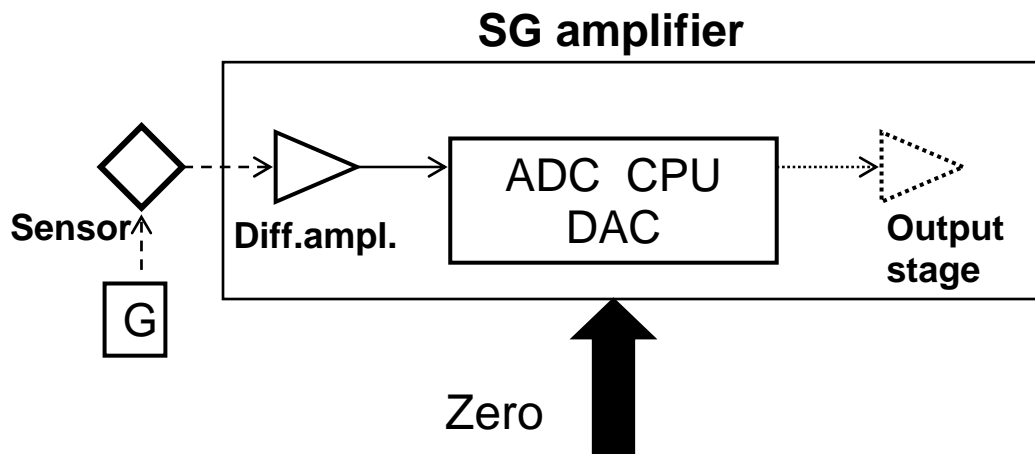

Fig. 5: Block diagram of SG amplifier with zeroing function

In brief:

Piezoelectric force measurement technology offers outstanding features for reliably monitoring assembly and test processes in production:

- Resolution and sensitivity are independent of the measuring range and allow for overload safe operation.
- The very compact design enables piezoelectric sensors to be used where space is a constraint.
- Extremely high stiffness and, at the same time, measurement with practically no displacement allow many measurements to be taken with high reliability.
- Charge signals can be easily added up.