

DATA SHEET

ClipX[®] BM40, BM40PB, BM40IE Industrial amplifier

SPECIAL FEATURES

- Freely configurable measurement channel with TEDS channel parameterization
- Connection of 7 transducer technologies with 19.2 kHz sample rate
- Accuracy class up to 0.01 with 32-bit A/D conversion
- 4 digital I/Os and 1 analog output (voltage/current reversible)
- Modular connectivity for up to 6 modules by ClipX bus with transfer of measured values
- Internal calculation channels (Smart functions)
- OPC UA, PPMP protocol, PROFINET[®] (IRT/RT), EtherCAT[®], EtherNet/IP[™], PROFIBUS[®] (DPV1), Modbus TCP
- Simple operation via integrated web server with 3 levels of user guidance
- Rugged and compact metal housing for attachment to DIN rail



BLOCK DIAGRAM

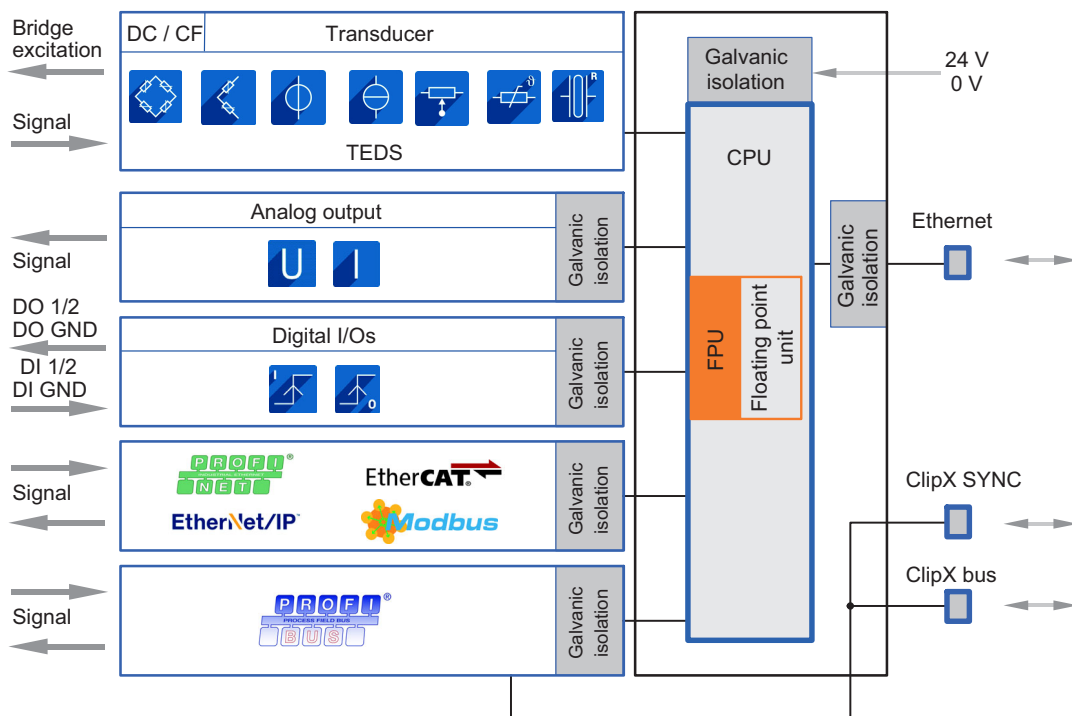

SPECIFICATIONS FOR CLIPX

General specifications		BM40, BM40PB, BM40IE
Measurement input	Number	1, galvanically isolated to supply
Transducer technologies		Full and half bridge strain gages, piezoresistive sensors (voltage-fed), potentiometric transducers, resistance thermometers (Pt100), electric voltage (± 10 V), electric current (± 20 mA)
A/D conversion	bit	32, delta-sigma converter
Sample rate	S/s	19200
Signal bandwidth (-3 dB)	Hz	Direct voltage sensor excitation (DC): 3800 Hz when filter off Carrier frequency sensor excitation (CF): 200 Hz
Active low-pass filter	Hz	Bessel or Butterworth 6th order, IIR DC: 0.02 ... 3000; filter OFF (3800) CF: 0.02 ... 200
Transducer identification		TEDS, IEEE 1451.4
Supported variants		Zero-wire TEDS and 1-Wire TEDS
TEDS module spacing, max.	m	100
Supply voltage range	V _{DC}	10 ... 30 (nominal (rated) voltage 24 V)
Supply voltage interruption (based on PLC standard DIN EN 61131-2)		
24 V (-10 %)	ms	10
12 V (-10 %)	ms	1
Power consumption at 24 V supply voltage, max.	W	5
Galvanic isolation	V	60
		Between power supply, sensor input, ClipX bus, analog output, all digital inputs and outputs, as well as fieldbuses apart from PROFIBUS
Fuses		None
Automatic current limiter		For all input and output signals
Short-circuit resistance		Input/output signals, synchronization and fieldbus are short-circuit proof and coding elements can be used to safeguard the connector plugs, so they are not transposed.
Ethernet (data link)		10Base-T / 100Base-TX
Protocol/addressing		TCP/IP (direct IP address or DHCP)
Plug connection		RJ45, 8-pin
Cable type		Standard LAN, CAT5, SFTP
Max. cable length to device	m	100
ClipX bus (data transfer)		
Number of devices, max.		6
Data transfer		1 data value (measured value, calculated value, etc.) with status
Transmission speed	kHz	1, with automatic synchronization
Protocol / addressing		RS485, node 1 ... 6
Cabling		Wires, twisted in pairs and shielded
Distance between 2 modules, max.	cm	30
Real time calculation in device		
Calculated Channels	Number	6

General specifications		BM40, BM40PB, BM40IE
Update rate Functions	ms	1 Matrix calculation (2x2 ... 6x6), 4:1 multiplexer, Tolerance window, Peak with capture, Trigger, Checkweigher, Floating mean value/RMS, Physical work, Bessel and Butterworth filters (IIR), FIR filter, Notch filter, Algebra (+ - * /), Counter, Differentiator, Coordinates transformation (Cartesian ↔ polar), PID controller, Logical function (AND, OR, NAND, NOR, XOR, XNOR, NOT), Signal generator, Pulse-width measurement, Timer, Standstill recognition
Peak-value memory Number Reference level Response time, typical	μs	3 Min, Max or Peak-to-Peak All measurement signals, all calculation channels, data from ClipX bus, fieldbus and Ethernet, analog output 52
Limit switches Number Reference level Function Response time, typical	μs	4 All measurement signals, all calculation channels, data from ClipX bus, fieldbus and Ethernet, analog output Exceeding or falling below a level Inside/outside a tolerance band 300
Digital inputs Number Function Response time, typical	ms	2 Zero, Tare, Reset Limit Value, Digital output, Toggle Parameter Sets (bit-coded), Flags for Calculated Channels 1
Digital outputs Number Function Response time, typical	ms	2 Designed as high-side switches Limit value, digital input, measured value/system status, fieldbus flag, current parameter set number (bit-coded), calculation channel flags and Ethernet flags 1
Parameter Sets Number Device "cloning" Switching time		10 Sensor settings, measurement acquisition incl. computation channels, limit values, digital input/output settings, analog output settings. All the device settings can be saved in full to a PC as a backup and reloaded, either with or without Ethernet and fieldbus settings. <100 ms plus settling time of low-pass filter; The measured value status is set to 'invalid' for 2.5 seconds so as to suppress transient responses.

General specifications		BM40, BM40PB, BM40IE
Internal device storage Freely usable Data memory (FIFO) Additional content	MByte	8 4,000 values of max. 6 signals, measured values, peak values, calculated values, values from fieldbus or Ethernet, from own ClipX or from other ClipX transmitted via ClipX bus. Own calibration certificate, manufacturer's certificate 2.1 according to EN 10204, device description files for the fieldbuses (BM40IE only); Windows PC software ClipX-Data-Viewer (with scope and data storage function).
Nominal (rated) temperature range	°C	0 ... 50
Storage temperature range	°C	-25 ... +75
Relative humidity	%	5 ... 95 (non-condensing)
Protection class (height up to 2,000 m, degree of pollution 2)		III (as per EN 61140)
Equipment protection level		IP20 (according to EN 60529)
Operating temperature range (no condensation allowed/module not immune to water condensation)	°C	-20 ... +60
Mechanical tests (device off, according to PLC hardware standard EN61131-2) Oscillation (90 min. in each direction) Impact (3 times in each direction)	g	2 (20 m/s ²); 8.4 ... 200 Hz (constant acceleration); 5 ... 8.4 Hz (constant amplitude 14 mm) 35 (350 m/s ²); sinusoidal; impact duration 6 ms
EMC requirements		Compliance with group 1, class B according to EN 55011 (Emissions). Compliance with criterion B for ESD and surge according to EN 61326-1 (Immunity).
Proof of quality		Manufacturer's certificate 2.1 according to EN 10204 and the HBM factory calibration certificate are stored in the device and can be downloaded from https://www.hbm.com/ClipX .
Long-term stability		All devices are pre-aged in an oven run to improve long-term stability.
Dimensions, (H x W x D), including DIN rail mounting material	mm	100 x 25 x 118
Weight, approx.	g	360

Strain gage full bridge		BM40, BM40PB, BM40IE
Accuracy class		0.01
Transducers that can be connected		Full bridge strain gages
Transducer impedance	Ω	80 ... 5000
Measurement ranges (at 5 V bridge excitation)	mV/V	2.5 or 5, reversible
Bridge excitation voltage	V	5 (± 10 %), direct voltage (DC) or carrier frequency (CF) 1200 Hz reversible
Signal bandwidth (-3 dB)	Hz	DC: 0 ... 3800 CF: 0 ... 200
Permissible cable length between ClipX and transducer	m	< 100
Transducer identification		TEDS, IEEE 1451.4; optionally 1-wire technology with separate TEDS module or HBM zero-wire technology with TEDS module in the sense leads of the sensor

Strain gage full bridge		BM40, BM40PB, BM40IE
Noise (peak-to-peak) at 25 °C, excitation 5 V (DC), 350 Ohm-Full bridge		
With 1 Hz Bessel filter	μV/V	0.04
With 10 Hz Bessel filter	μV/V	0.12
With 100 Hz Bessel filter	μV/V	0.4
With 1 kHz Bessel filter	μV/V	1.2
Noise (peak-to-peak) at 25 °C, excitation 5 V (CF), 350 Ohm-Full bridge		
With 1 Hz Bessel filter	μV/V	0.05
With 10 Hz Bessel filter	μV/V	0.16
With 100 Hz Bessel filter	μV/V	0.5
With 200 Hz Bessel filter	μV/V	0.8
Non-linearity	%	0.005 of full scale value
Zero drift (5 V excitation)	%/10 K	0.01 of full scale value
Full scale drift (5 V excitation)	%/10 K	0.01 of measured value
Full bridge strain gage with Zener barriers		
Accuracy class		
at 80 Ω transducer impedance, 6-wire configuration, max. 100 m cable length and DC or CF		0.2
at 350 Ω transducer impedance, 6-wire configuration, max. 100 m cable length and DC or CF		< 0.05
at 350 Ω ... 5 kΩ transducer impedance, 6-wire configuration, max. 100 m cable length and DC		0.05

Half bridge strain gage		BM40, BM40PB, BM40IE
Accuracy class		0.1
Transducers that can be connected		Strain gage half bridges
Transducer impedance	Ω	80 ... 5000
Measurement ranges (at 5 V bridge excitation)	mV/V	2.5 or 5; reversible
Bridge excitation voltage	V	5 (± 10 %), direct voltage (DC) or carrier frequency (CF) 1200 Hz reversible
Signal bandwidth (-3 dB)	Hz	DC: 0 ... 3800 CF: 0 ... 200
Permissible cable length between ClipX and transducer	m	< 100
Transducer identification		TEDS, IEEE 1451.4; optionally 1-wire technology with separate TEDS module or HBM zero-wire technology with TEDS module in the sense leads of the sensor
Noise (peak-to-peak) at 25 °C, excitation 5 V (DC), 350 Ohm-Half bridge		
With 1 Hz Bessel filter	μV/V	0.08
With 10 Hz Bessel filter	μV/V	0.24
With 100 Hz Bessel filter	μV/V	0.8
With 1 kHz Bessel filter	μV/V	2.4
Noise (peak-to-peak) at 25 °C, excitation 5 V (CF), 350 Ohm-Half bridge		
With 1 Hz Bessel filter	μV/V	0.1
With 10 Hz Bessel filter	μV/V	0.32
With 100 Hz Bessel filter	μV/V	1
With 200 Hz Bessel filter	μV/V	1.6
Non-linearity	%	0.05 of full scale value
Zero drift (5 V excitation)	%/10 K	0.1 of full scale value
Full scale drift (5 V excitation)	%/10 K	0.1 of measured value

Resistive full bridge		BM40, BM40PB, BM40IE
Accuracy class		0.01
Transducers that can be connected		Resistive full bridge, voltage-fed
Transducer impedance	Ω	80 ... 5000
Measurement ranges (at 5 V bridge excitation)	mV/V	100 or 800, reversible
Bridge excitation voltage	V	5 ($\pm 10\%$), direct voltage (DC)
Signal bandwidth (-3 dB)	Hz	DC: 0 ... 3800
Permissible cable length between ClipX and transducer	m	<100
Transducer identification		TEDS, IEEE 1451.4; optionally 1-wire technology with separate TEDS module or HBM zero-wire technology with TEDS module in the sense leads of the sensor
Noise (peak-to-peak) at 25 °C, at 100 mV/V, excitation 5 V (DC), 350 Ohm-Full bridge		
With 1 Hz Bessel filter	$\mu\text{V}/\text{V}$	0.2
With 10 Hz Bessel filter	$\mu\text{V}/\text{V}$	0.4
With 100 Hz Bessel filter	$\mu\text{V}/\text{V}$	1.5
With 1 kHz Bessel filter	$\mu\text{V}/\text{V}$	5
Noise (peak-to-peak) at 25 °C, at 800 mV/V, excitation 5 V (DC), 350 Ohm-Full bridge		
With 1 Hz Bessel filter	$\mu\text{V}/\text{V}$	0.6
With 10 Hz Bessel filter	$\mu\text{V}/\text{V}$	1.2
With 100 Hz Bessel filter	$\mu\text{V}/\text{V}$	4.5
With 1 kHz Bessel filter	$\mu\text{V}/\text{V}$	15
Non-linearity	%	0.005 of full scale value
Zero drift (5 V excitation)	%/10 K	0.01 of full scale value
Full scale drift (5 V excitation)	%/10 K	0.01 of measured value

Potentiometric transducers/potentiometers		BM40, BM40PB, BM40IE
Accuracy class		0.1
Transducers that can be connected		Potentiometric transducers
Transducer impedance	Ω	80 ... 5000
Measurement ranges (at 5 V bridge excitation)	mV/V	500, corresponding to 0 ... 100 %
Bridge excitation voltage	V	5 ($\pm 10\%$), direct voltage (DC)
Signal bandwidth (-3 dB)	Hz	DC: 0 ... 3800
Permissible cable length between ClipX and transducer	m	<100
Transducer identification		TEDS, IEEE 1451.4; 1-wire technology with separate TEDS module
Noise (peak-to-peak) at 25 °C, potentiometer, excitation 5 V (DC), 10 kΩ potentiometer, mid position		
With 1 Hz Bessel filter	%	0.00008
With 10 Hz Bessel filter	%	0.00025
With 100 Hz Bessel filter	%	0.001
With 1 kHz Bessel filter	%	0.003
Non-linearity	%	0.05 of full scale value
Zero drift (5 V excitation)	%/10 K	0.1 of full scale value
Full scale drift (5 V excitation)	%/10 K	0.1 of measured value

Resistance thermometers (Pt100)		BM40, BM40PB, BM40IE
Accuracy	°C	0.5
Transducers that can be connected		Pt100 (connected in 3-wire configuration)
Linearization range	°C	-200 ... +850
Signal bandwidth (-3 dB)	Hz	DC: 0 ... 3800
Permissible cable length between ClipX and transducer	m	<100
Transducer identification		TEDS, IEEE 1451.4; 1-wire technology with separate TEDS module
Noise (peak-to-peak) at 25 °C, Pt100 at 100 Ohm		
With 1 Hz Bessel filter	K	0.008
With 10 Hz Bessel filter	K	0.012
With 100 Hz Bessel filter	K	0.06
With 1 kHz Bessel filter	K	0.2
Non-linearity	%	<0.5
Zero drift	K / 10 K	<0.2
Full-scale drift	K / 10 K	<1

Voltage		BM40, BM40PB, BM40IE
Accuracy class		0.05
Transducers that can be connected		Voltage sources
Transducer impedance	MΩ	>1
Measurement range	V	± 10
Signal bandwidth (-3 dB)	Hz	DC: 0 ... 3800
Permissible cable length between ClipX and transducer	m	< 100
Transducer identification		TEDS, IEEE 1451.4; 1-wire technology with separate TEDS module
Noise at voltage input ± 10 V		
With 1 Hz Bessel filter	mV	0.05
With 10 Hz Bessel filter	mV	0.10
With 100 Hz Bessel filter	mV	0.25
With 1 kHz Bessel filter	mV	0.75
Common-mode rejection		
for DC common mode	dB	>120
for 50/60 Hz common mode, typical	dB	>80
Common-mode voltage, max. (to housing and supply ground)	V	± 30
Non-linearity	K	0.05 of full scale value
Zero drift	K / 10 K	0.05 of full scale value
Full-scale drift	K / 10 K	0.05 of measured value

Signal current		BM40, BM40PB, BM40IE
Accuracy class		0.05
Transducers that can be connected		Transducers with current output
Measuring resistance value, typical	Ω	<15
Measurement range	mA	4 ... 20, ± 20 mA, reversible
Signal bandwidth (-3 dB)	Hz	DC: 0 ... 3800
Permissible cable length between ClipX and transducer	m	< 100
Transducer identification		TEDS, IEEE 1451.4; 1-wire technology with separate TEDS module

Signal current		BM40, BM40PB, BM40IE
Noise at current input ± 20 mA		
With 1 Hz Bessel filter	μA	0.05
With 10 Hz Bessel filter	μA	0.1
With 100 Hz Bessel filter	μA	0.5
With 1 kHz Bessel filter	μA	2
Common-mode rejection		
for DC common mode	dB	>120
for 50/60 Hz common mode, typical	dB	>80
Common-mode voltage, max. (to housing and supply ground)	V	± 30
Non-linearity	%	0.05 of full scale value
Zero drift	K / 10 K	0.05 of full scale value
Full-scale drift	K / 10 K	0.05 of measured value

Input / Output

Analog output		BM40, BM40PB, BM40IE
Voltage output		
Accuracy class		0.05
Number		1
Signal sources		All measurement signals, all calculation channels, data from ClipX bus, fieldbus and Ethernet
Output signal	V	± 10 ; reversible, short-circuit proof
D/A converter resolution	bit	16
Output rate, max.	kHz	19.2
Cutoff frequency (-3 dB)	kHz	2
Output resistance	Ω	<320
Permissible input impedance		10 k Ω 20 nF
Permissible cable length, max.	m	100
Noise (peak-to-peak)	mV	<10
Integral Non Linearity (INL)	LSB	< ± 27
Zero drift rel. to full scale	mV / 10 K	<2
Full-scale drift rel. to output value	mV / 10 K	<2
Current output		
Accuracy class		0.05
Number		1
Signal sources		All measurement signals, all calculation channels, data from ClipX bus, fieldbus and Ethernet
Output signal	mA	4 ... 20 mA, reversible, short-circuit proof
D/A converter resolution	bit	16
Output rate, max.	kHz	19.2
Cutoff frequency (-3 dB)	kHz	2
Permitted burden	Ω	<400
Permissible cable length, max.	m	100
Noise (peak-to-peak)	μA	<60
Integral Non Linearity (INL)	LSB	< ± 27
Zero drift rel. to full scale	μA / 10 K	<5
Full-scale drift rel. to output value	μA / 10 K	<10

Digital inputs		BM40, BM40PB, BM40IE
Number		2
Functions		Zero, Tare, Reset Limit Value, Digital output, Toggle Parameter Sets (bit-coded), Flags for Calculated Channels
Switching time	ms	< 1
Input signal range	V	0 ... 30
Maximum permitted input signal range	V	30
Low state input	V	0 ... 5 (or open)
High state input	V	10 ... 30
Input resistance (nominal)	kΩ	2.4
Cable length, max.	m	100
Cable type (required in the event of interference)		shielded

Digital outputs		BM40, BM40PB, BM40IE
Number		2, short-circuit proof
Functions		Limit value, digital input, measured value/system status, fieldbus flag, current parameter set number (bit-coded), calculation channel flags
Switching time	ms	<1
Input voltage	V	Operating voltage
Output current per output, max.	mA	200
Output current (outputs total), max.	mA	400
Output impedance	Ω	<1
Start-up behavior		Low until the ClipX transmits the required level

Ethernet access

Access method and parameters		BM40, BM40PB, BM40IE
Maximum number of connections (including in parallel)		2 x web server, 1 x TCP/IP, 2 x OPC UA
Direct access via Ethernet (TCP/IP)		starting with firmware 1.2
Port		55000
Access method		SDO read and write commands, access to ClipX FIFO
OPC UA Server		Starting with hardware 2.0 and firmware 1.4 or higher
Profiles		Micro
Transport		TCP/IP binary
Security		Username and Password
Methods		Supported
Historical data access		Not supported
Number of sessions		2
Subscriptions per session		1
Items per subscription		6
Item queue size		10
Minimum publishing interval	ms	100
Minimum sample interval	ms	20
PPMP protocol		Starting with firmware 2.8
Specification		https://www.eclipse.org/unide/specification/
Type of message		Measured data message V2
Protocol and request method		HTTP/1.1 POST
Content type		json

Access method and parameters		BM40, BM40PB, BM40IE
Sampling interval (for measured values)	ms	10 ... 60000, adjustable in steps of 10 ms
Transmission interval (for packet with measured values)	ms	100 ... 60000
Measured values per channel and HTTP packet		max. 100
Number of measured values per packet		max. 600
Number of transmitted channels		1 ... 6
Resolution of the values	No. of decimal places	1 ... 6, adjustable per channel

Fieldbuses

PROFIBUS		BM40PB
Bit rate	kBit/s	9,6 ... 12000 auto-detect
Node address		3 ... 126 adjustable via the web user interface Factory setting: 126
Configuration data, max.	bytes	244
Logical slots		30
Cyclic output data (master -> ClipX), max.	bytes	160
Cyclic input data (ClipX -> master), max.	bytes	160
Cycle time (slave interval), min.	ms	0.6
Acyclic data protocol		DP V1 Class 1 and Class 2 A list with the data objects can be downloaded via the web user interface
Acyclic data, max.	bytes	240
Male connector		D-Sub 9-pin; galvanically isolated from supply and measurement ground
PROFIBUS Ident No.		0x1015

Industrial Ethernet IE		BM40IE
The operator can switch fieldbus type in the BM40IE via the ClipX web server		
EtherCAT^{®1)}		
Type		EtherCAT complex slave
Cable type		Standard CAT-5, shielded
Cable length, max.	m	100
Connector socket		2x RJ45 (IN / OUT)
Hot-plug possible		Yes
Input data, max.	bytes	166
Output data, max.	bytes	44
Online device description		CAN over EtherCAT Object Dictionary (ESI file not required)
Offline device description		ESI file stored in the device
Data transfer rate, max.	kHz	4
Distributed clocks		Supported, 32 bits
Minimum cycle time	µs	250
EtherNet/IP^{™2)}		
Type		Communication adapter
Cable type		Standard CAT-5, shielded
Cable length, max.	m	100
Connector socket		2 x RJ45

Industrial Ethernet IE		BM40IE
Input data, max.	bytes	166
Output data, max.	bytes	44
IO connection types		Exclusive owner, Listen only, Input only
IO connection trigger types		Cyclic, minimum 1 ms ³⁾ , Application triggered, minimum 1 ms ³⁾ , Change of state, minimum 1 ms ³⁾
Explicit messages connections		10
Implicit messages connections		5
Unconnected Message Manager (UCMM)		10
Configuration control		STATIC, BOOTP, DHCP
Bit rates	Mbit/s	10, 100
Duplex modes		Half, full, auto negotiation
Data transport layer		Ethernet II, IEEE 802.3
Address collision detection		supported
Device level ring		supported
Integrated switch		supported
Reset services		Type 0, type 1
Quick connect		not supported
Tags		not supported
CIP sync		not supported

1) EtherCAT® is a registered brand and patented technology, licensed by Beckhoff Automation GmbH, Germany.

2) EtherNet/IP™ is a trademark of ODVA Inc. For more information regarding ODVA, visit www.odva.org.

3) Depends on the number of connections and the IO quantities.

PROFINET		
Cable type		Standard CAT-5, shielded
Cable length, max.	m	100
Connector socket		2x RJ45 (port1 / port 2)
Realtime classes		1 ("RT") / 3 ("IRT")
Device access point "slow"		
Cycle time Class 1	ms	1 / 2 / 4
Cycle time Class 3	ms	1 / 2 / 4
Slots / max. number of modules	-	30
Input data, max.	bytes	180
Output data, max.	bytes	100
Device access point "fast"		
Cycle time Class 1	ms	1 / 2 / 4
Cycle time Class 3	ms	0.25 / 0.5 / 1 / 2 / 4
Slots / max. number of modules		6
Input data, max.	bytes	60
Output data, max.	bytes	40
Supported protocols		RTC (Real Time Cyclic) Class 1, unsynchronized Class 3, synchronized RTA - Real Time Acyclic DCP - Discovery and Configuration DCE/RPC - Distributed Computing Environment - Connectionless Remote Procedure Calls LLDP - Link Layer Discovery Protocol

		PTCP - Precision Transparent Clock Protocol
		SNMP - Simple Network Management Protocol
Media redundancy		MRP client
Identification & maintenance		I&M0 ... I&M3 read and write
Modbus TCP		
Cable type		Standard CAT-5, shielded
Cable length, max.	m	100
Connector socket		2 x RJ45
Bit rates	Mbit/s	10, 100
Maximum number of connections		16
Function codes	FC 1 FC 2 FC 3 FC 4 FC 5 FC 6 FC 15 FC 16 FC 23	Read coils Read input discretes Read multiple registers Read input registers Write coil Write single register Force multiple coils Write multiple registers Read/Write multiple registers
Maximum number of registers per write telegram	FC 3, 4, 23	125
Maximum number of registers per write telegram	FC 16	123
Maximum number of registers per write telegram	FC 23	121
Maximum number of coils per read telegram	FC 1, 2	2000
Maximum number of coils per write telegram	FC 15	1968

SIGNAL DELAYS (MS)

The following table contains the phase delays of the A/D converter plus digital filter. Some filter frequencies are only possible with a DC amplifier. The bandwidth with DC and the digital filter switched off (Filter OFF) is 3800 Hz. The filter phase delay is then 0 ms, meaning the phase delay of the A/D converter with no filter is 260 µs.

Cut-off frequency in Hz (-3 dB)	Phase delay with Bessel filter in ms	Phase delay with Butterworth filter in ms
3000 (DC only)	0.403	0.480
2500 (DC only)	0.432	0.524
2000 (DC only)	0.475	0.590
1500 (DC only)	0.547	0.700
1000 (DC only)	0.690	0.920
800 (DC only)	0.798	1.085
750 (DC only)	0.833	1.140
600 (DC only)	0.977	1.360
500 (DC only)	1.120	1.580
400 (DC only)	1.335	1.910
350 (DC only)	1.489	2.146
280 (DC only)	1.796	2.617
250 (DC only)	1.980	2.900
200	2.410	3.560
160	2.948	4.385
150	3.127	4.660

Cut-off frequency in Hz (-3 dB)	Phase delay with Bessel filter in ms	Phase delay with Butterworth filter in ms
120	3.843	5.760
100	4.560	6.860
80	5.635	8.510
75	5.993	9.060
60	7.427	11.260
50	8.860	13.460
40	11.010	16.760
35	12.546	19.117
30	14.593	22.260
25	17.460	26.660
20	21.760	33.260
16	27.135	41.510
15	28.927	44.260
12	36.093	55.260
10	43.260	66.260
8	54.010	82.760
7.5	57.593	88.260
6	71.927	110.260
5	86.260	132.260
4	107.76	165.26
3.5	123.12	188.83
3	143.59	220.26
2.5	172.26	264.26
2	215.26	330.26
1.6	269.01	412.76
1.2	358.59	550.26
1	430.26	660.26
0.8	537.76	825.26
0.75	573.59	880.26
0.6	716.93	1100.26
0.5	860.26	1320.26
0.4	1075.26	1650.26
0.35	1228.83	1885.97
0.28	1535.97	2357.40
0.25	1720.26	2640.26
0.2	2150.26	3300.26
0.16	2687.76	4125.26
0.15	2866.93	4400.26
0.1	4300.26	6600.26
0.075	5733.59	8800.26
0.05	8600.26	13200.26
0.035	12286.0	18857.4
0.025	17200.3	26400.3
0.02	21500.3	33000.3

Group 1: Measured values

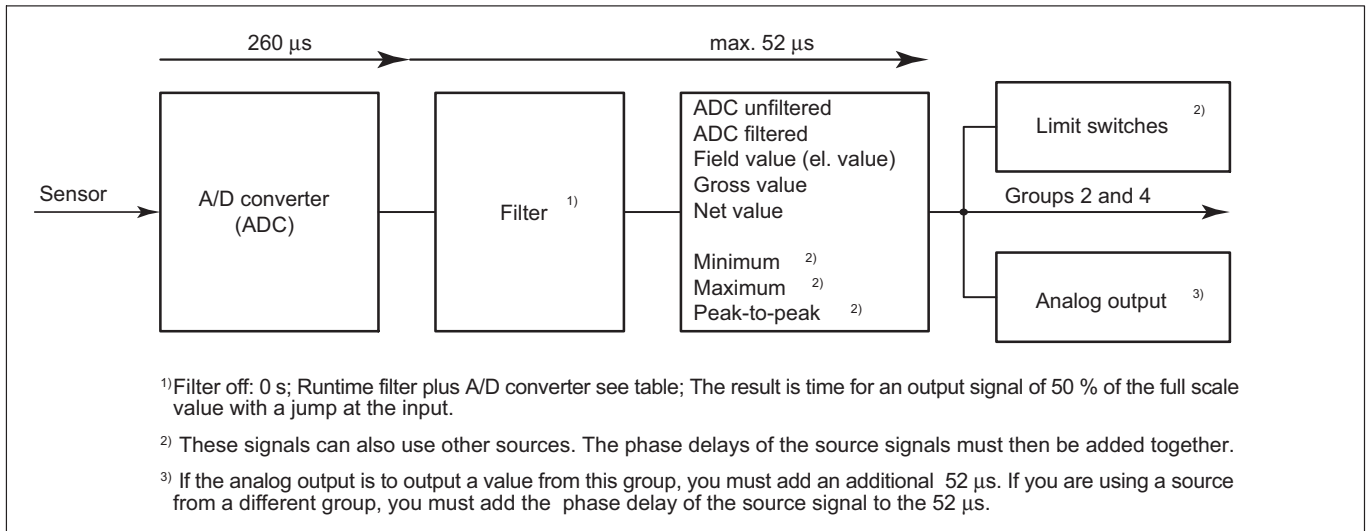

Fig. 1: Minimum phase delays for group 1: 52 ms plus A/D converter conversion time plus filter runtime

Some signals might also have sources from other groups. For example, the analog output might deliver a signal from the ClipX bus. In these cases, you must add the propagation time of the source signal's group in order to get the total propagation time:

Example 1

Phase delay from input, e.g. 10 V, 20 mA or DC full/half bridge, to analog output (10 V) with a Bessel filter at 1 kHz:

A/D converter (ADC) plus filter: 690 µs.

Added to this is a jitter of up to 52 µs, as the A/D converter is not synchronized with group 1. Group 1: 690 µs + 52 µs max.

Analog output: 52 µs.

So the total phase delay is 742 ... 794 µs.

Group 2: Flags, Digital I/Os, calculated values, ClipX bus

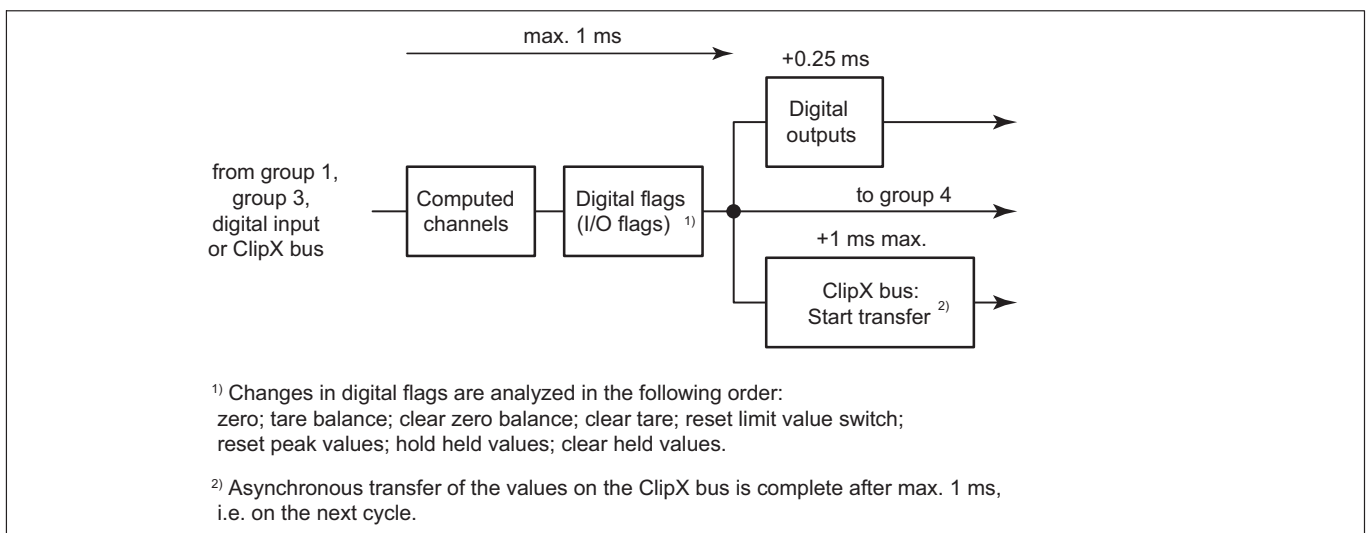

Fig. 2: Maximum phase delay for group 2: 1 ms

Example 2

Phase delay from input (see group 1) to a digital output with a Bessel filter at 1 kHz, limit switch at half the step height.

A/D converter (ADC) plus filter: 690 μ s.
 Added to this is a jitter of up to 52 μ s, as the A/D converter is not synchronized with group 1.
 Group 1: 690 μ s + 52 μ s max.
 Group 2: 1 ms
 Digital output: max. 250 μ s response time

In the best case, a value is available at the start of the analysis in group 2 and can be outputted directly at the digital output. So the total phase delay is 940 ... 1992 μ s.

Example 3

Phase delay of a value from the ClipX bus via a limit switch to a digital output.

Group 2: 1 ms max.
 Digital output: 250 μ s response time.

In the best case, a value is available at the start of the analysis in group 2 and can be outputted directly at the digital output. However, you must add the phase delay in the device that places the value on the ClipX bus in order to get the time from the sensor until a response occurs: 1.69 ms min. and 2.742 ms max. with 1 kHz Bessel filter. So the total phase delay is 1.94 ... 3.992 ms.

Group 3: Data from fieldbus master to ClipX

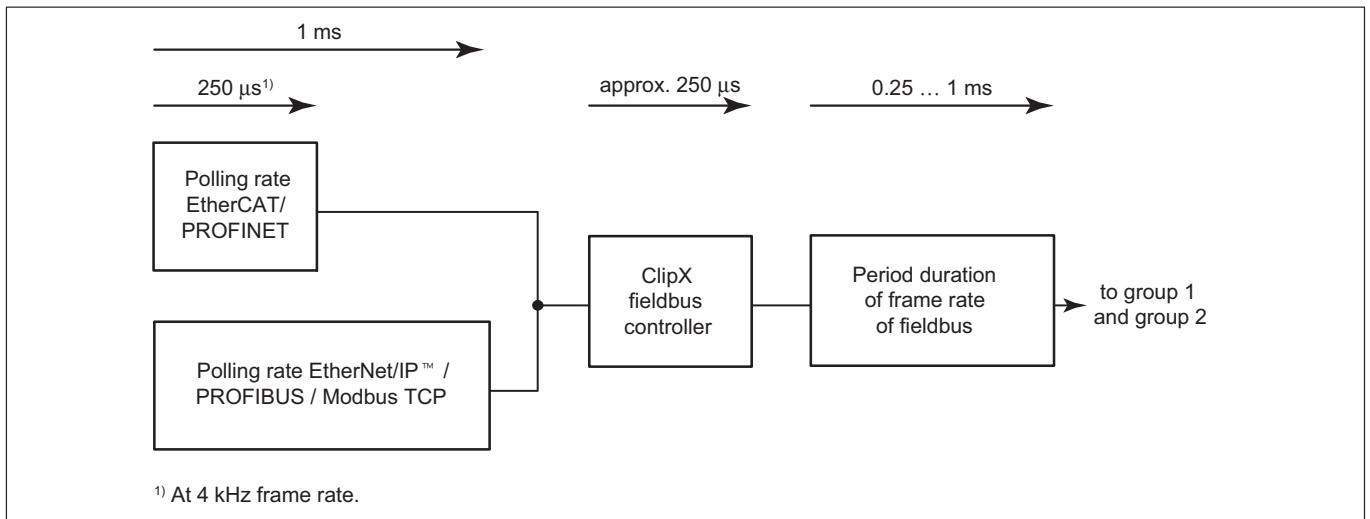

Fig. 3: Phase delay for group 3

Example 4

Signal delay from fieldbus master (PLC) to ClipX. From there it can be further processed or outputted as an analog signal.

Fieldbus output for EtherCAT or PROFINET (4 kHz frame rate): 250 μ s + 250 μ s + 250 μ s = 750 μ s.

After this time the signal is available in the ClipX.

If you want to output the signal via the analog output of this ClipX, 52 μ s is added (group 1), i.e. the total phase delay is then 802 μ s.

If you want to calculate the signal via an internal calculation channel before analog output, another millisecond is added, i.e. the total phase delay in this case is 1802 μ s.

Group 4: Data from ClipX to fieldbus master

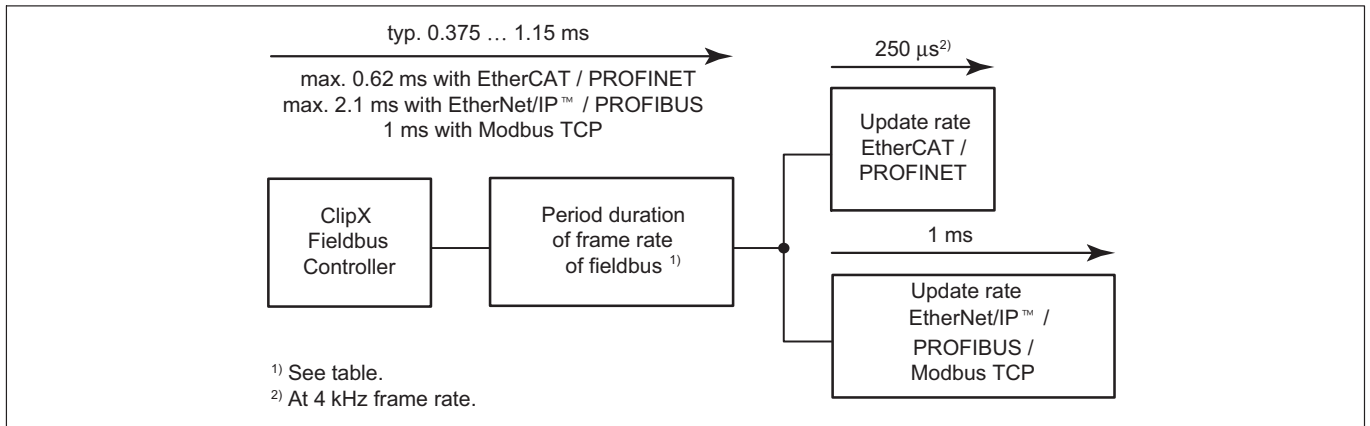

Fig. 4: Phase delay for group 4

Phase delays of group 4

Fieldbus	Data transfer in ms	Phase delay typ. in ms	Phase delay max. in ms
EtherCAT / PROFINET	0.25	0.25 + frame rate/2	0,37 + frame rate
EtherNet/IP™ / PROFIBUS	1	0.65 + frame rate/2	1,1 + frame rate
Modbus TCP	1	–	–

Example 5

Signal delay from the input (group 1) with a Bessel filter with 1 kHz to the fieldbus master (group 4).

A/D converter (ADC) plus filter: 690 µs.

Added to this is a jitter of up to 52 µs, as the A/D converter is not synchronized with group 1.

Group 1: 690 µs + 52 µs max.

Fieldbus output with EtherCAT or PROFINET (4 kHz frame rate): max. 370 µs + 250 µs + 250 µs (typ. 250 µs + 125 µs + 250 µs = 625 µs).

So the total phase delay is between 1.315 ms (min.) and 1.612 ms (max.).

GROUP OVERVIEW

The following overview shows the correlations and phase delays of the four groups.

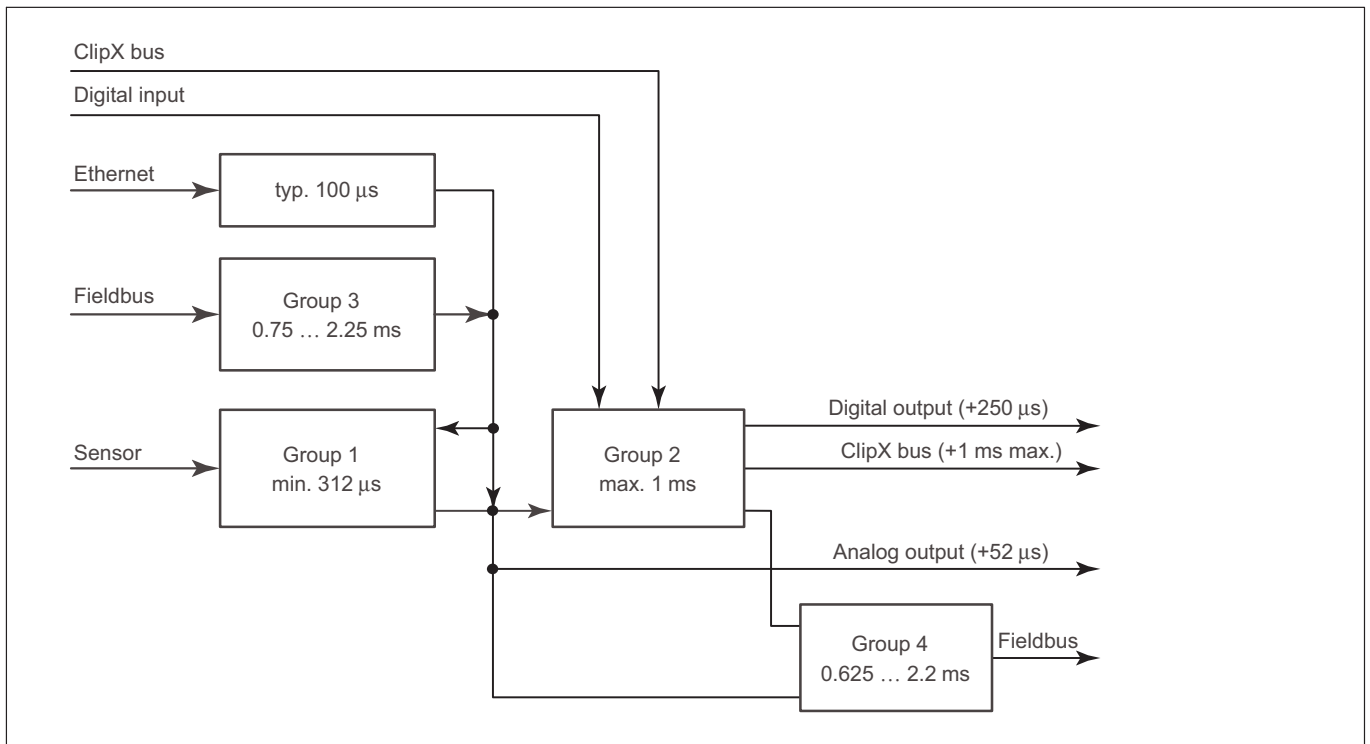
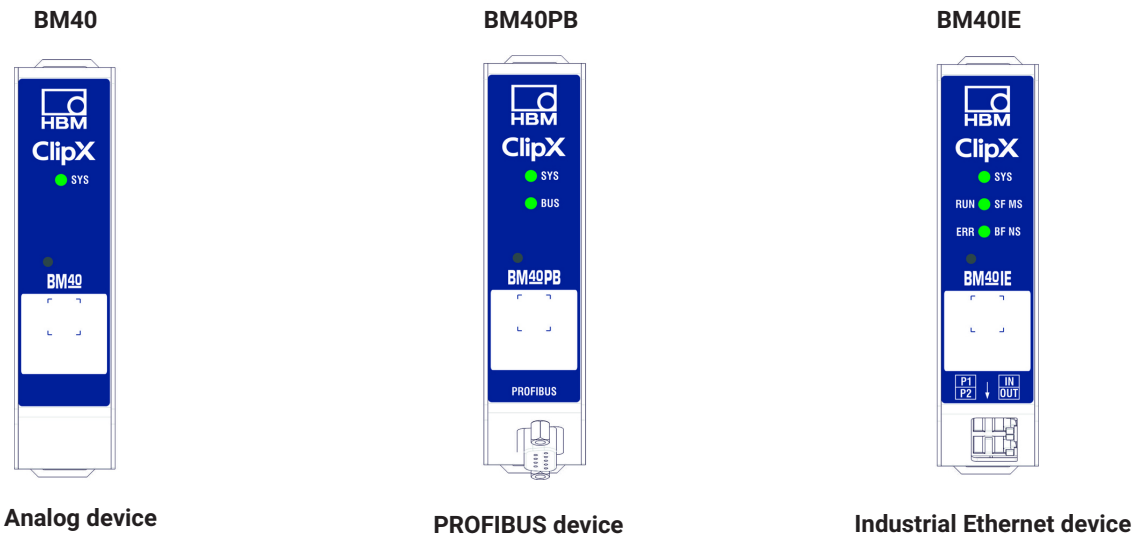
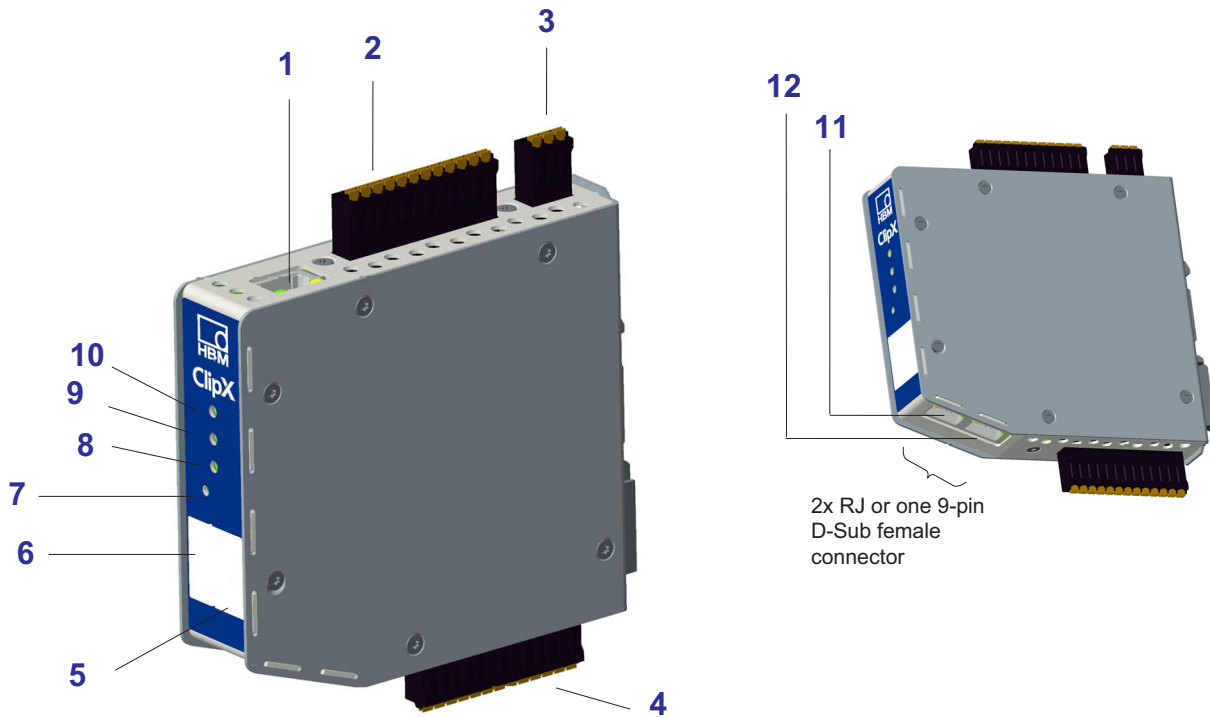

Fig. 5: All groups with inputs and outputs

CLIPX VARIANTS



FUNCTION OVERVIEW



- | | |
|---|--|
| 1 Ethernet connection | 7 Function push button |
| 2 Supply voltage, Digital I/O, ClipX bus | 8 LED fieldbus status 2 |
| 3 Analog output | 9 LED fieldbus status 1 |
| 4 Transducer connection | 10 LED system status |
| 5 Customer-specific label | 11 P1 IN } RealTime, EtherNet/IP™;
PROFINET, EtherCAT, |
| 6 HBM calibration mark | 12 P2 OUT } Modbus-TCP |

PIN ASSIGNMENT

1 Ethernet (communication); RJ45

Standard assignment

Plug terminals :

2 Supply, digital I/O, ClipX bus, 12-pin (Phoenix MC1.5/12-G-3.5)

	24 V	Power supply
	0 V	Power supply / Digital Out GND
	DO1	Digital Out 1
	DO2	Digital Out 2
	DI1	Digital In 1
	DI2	Digital In 2
	\perp DI	Digital In GND
	Sync	
	CxB	ClipX bus B (RS485-)
	\perp X	ClipX-Bus GND
	CxA	ClipX bus A (RS485+)



3 Analog output, 3-pin (Phoenix MC1,5/12-G-3.5)

	\perp AO	Analog Out Gnd
	AO	Analog Out



4 Transducer, 13-pin (Phoenix MC1,5/13-G-3.5)

	Pt100	
	TEDS	
	\perp S	Inner cable shield
	4	Measurement signal -
	1	Measurement signal +
	2'	Sense lead -
	2	Bridge excitation voltage -
	3'	Sense lead +
	3	Bridge excitation voltage +
	\perp AI	Outer cable shield
	I IN	
	U IN	

Shield connection clamp for strain relief (included with delivery)



Alternatively to plug terminals:

Screw terminals, obtained directly from Phoenix



DIMENSIONS

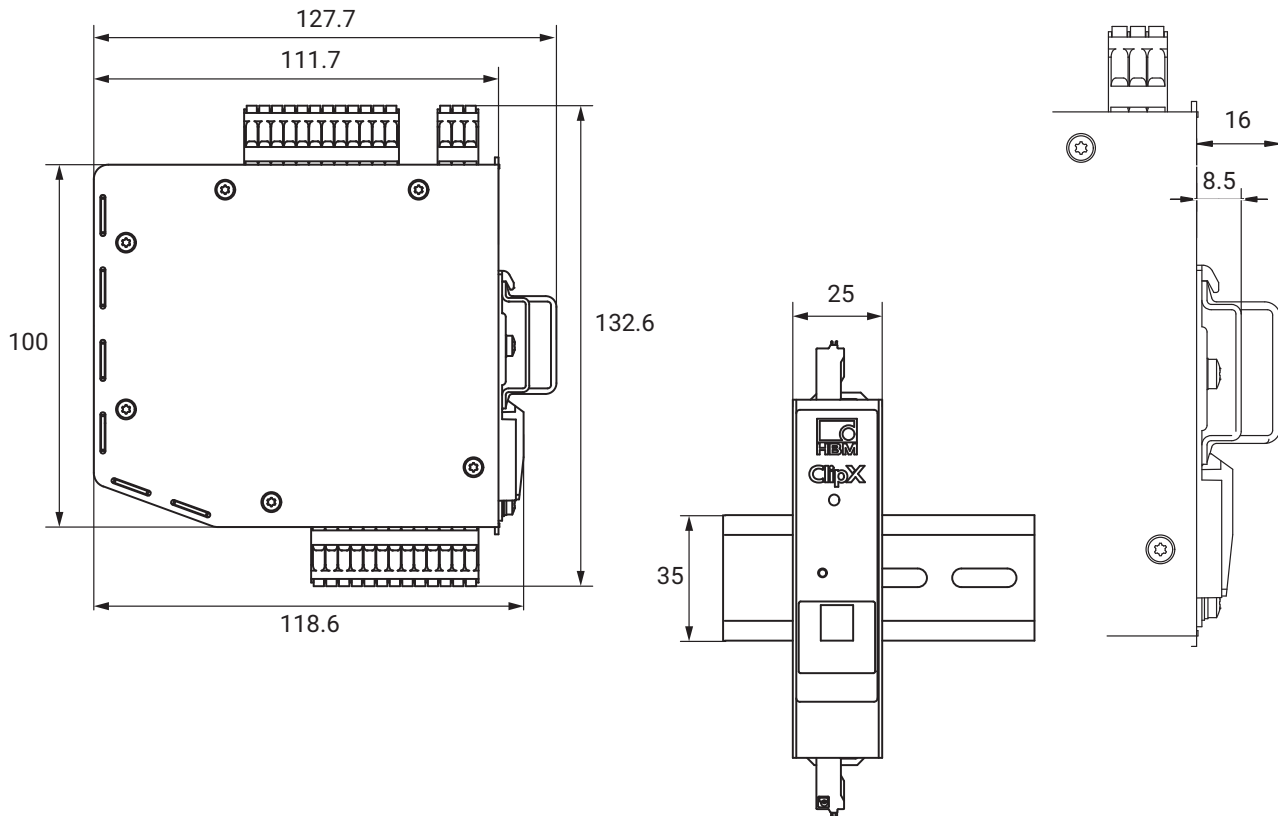

Note: ClipX devices can be manually fitted to the DIN rail and removed without the need for tools. To help with construction, ready-prepared ePLAN macros (no license required) and 3D STEP files are available free of charge at <https://www.hbm.com/ClipX>.

REPLACEMENT PARTS

Accessories	Ordering number
Ethernet cable For direct operation of devices on a PC or laptop, length 2 m, type CAT-5+	1-KAB239-2
ClipX plug set (3x push-in) Three-piece plug terminal set for sensor connection, power supply and analog output, including coding pins	1-CON-S1019
Shield connection clamp ME-SAS MINI - 2200456 from PHOENIX Shield connection clamp for cable strain relief	1-CON-A1023

Note: A plug terminal set and a shield connection clamp are included with the delivery

ClipX - CONNECTIVITY

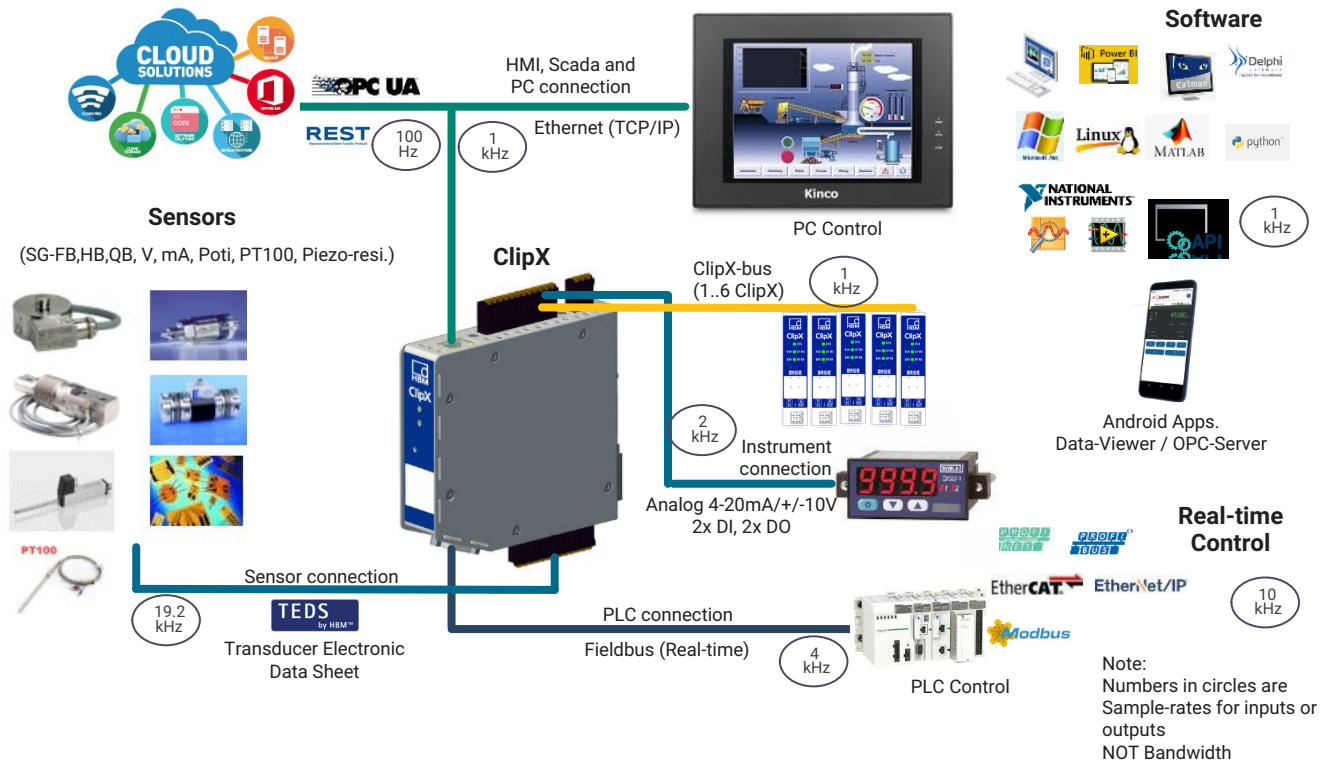

All software packages can be downloaded free of charge or as trial versions from the ClipX website. They include detailed assistance and program examples for you to run:
<https://www.hbm.com/en/7077/clipx-precise-industrial-signal-conditioner/>

Hottinger Brüel & Kjaer GmbH
 Im Tiefen See 45 · 64293 Darmstadt · Germany
 Tel. +49 6151 803-0 · Fax +49 6151 803-9100
www.hbkworld.com · info@hbkworl.com

Subject to modifications. All product descriptions are for general information only. They are not to be understood as a guarantee of quality or durability.