

ENGLISH

Mounting Instructions



TI2HP

Digital torque transducer

Hottinger Brüel & Kjaer GmbH
Im Tiefen See 45
D-64293 Darmstadt
Tel. +49 6151 803-0
Fax +49 6151 803-9100
info@hbkworld.com
www.hbkworld.com

Mat.: 7-2002.4515
DVS: A04515 05 E00 01
02.2024

© Hottinger Brüel & Kjaer GmbH

Subject to modifications.
All product descriptions are for general information
only. They are not to be understood as a guarantee of
quality or durability.

TABLE OF CONTENTS

1	Safety instructions	5
2	Markings used	10
2.1	Symbols attached to the transducer and/or stator	10
2.2	The markings used in this document	11
3	Scope of supply	12
4	Operation	13
5	Application	14
6	Signal flow	15
7	Structure and mode of operation	17
8	Mechanical installation	18
8.1	Important precautions during installation	18
8.2	Conditions on site	19
8.3	Mounting position	19
8.4	Information on the slotted screw (with rotational speed measuring systems only)	19
8.5	Installing the rotor	20
8.6	Fitting the protection against contact (option)	23
8.7	Installing the stator	28
8.7.1	Preparing with the mounting kit (incl. among the items supplied)	30
8.7.2	Aligning the stator	32
8.7.3	Stator installation over the protection against contact (option)	34
8.8	Optical measuring system for speed/angle of rotation (option)	35
8.8.1	Axial alignment	35
8.8.2	Radial alignment	36
9	LED status display	38
9.1	Measuring mode operation	38
9.2	Rotor clearance setting mode operation	38
9.3	Rotational speed measuring system setting mode operation	39
10	Electrical connection	40
10.1	General information	40
10.1.1	Using the EMI filter/toroidal strip-wound core, for applications in the USA and Europe	40

10.2	Shielding design	42
10.3	Pin assignment	43
10.4	Supply voltage	48
11	Shunt signal	49
12	Load-carrying capacity	50
13	TEDS	51
14	T12-Assistent, Version 1.2	60
15	Maintenance	69
16	Waste disposal, environmental protection	70
17	Specifications	71
17.1	Nominal (rated) torque 100 N·m to 1 kN·m	71
17.2	Nominal (rated) torque 2 kN·m to 10 kN·m	81
18	Dimensions	92
19	Supplementary technical information	93
20	Condition at the time of delivery	94
21	Ordering numbers	100
22	Accessories	102
23	Compatibility between T12HP and T12	104
24	Dimensions	109
25	Detail drawing T12HP	118

1 SAFETY INSTRUCTIONS

Adherence to FCC Rules and warning notice



Important

Every variation or modification that is not explicitly agreed with the person responsible for adherence to the Rules, could invalidate the user's operating license for the device. If additional components or accessories are defined elsewhere for use during installation of the product, these additional components or accessories must be used, to ensure adherence to FCC Rules.

This device complies with Part 15 of the FCC regulations. Compliance with the following two conditions is a requirement of operation: (1) This device may not cause harmful interference; and (2) this device must tolerate any interference signal received, including interference that could cause undesirable operation.

The FCC identification number or the unique identification number, as appropriate in each case, must be attached to the device where it is clearly visible.

Model	Measurement range	FCC ID	IC
T12S2	100 Nm, 200 Nm	2ADAT-T12S2	12438A-T12S2
T12S3	500 Nm, 1 kNm	2ADAT-T12S3	12438A-T12S3
T12S4	2 kNm, 3 kNm	2ADAT-T12S4	12438A-T12S4
T12S5	5 kNm	2ADAT-T12S5	12438A-T12S5
T12S6	10 kNm	2ADAT-T12S6	12438A-T12S6

The FCC ID number in relation to the measurement range.



Fig. 1.1 Position of the label on the device stator

Model: T12S3
 FCC ID: 2ADAT-T12S3
 IC: 12438A-T12S3

This device complies with part 15 of the FCC Rules. Operation is subject to the following two conditions: (1) This device may not cause harmful interference, and (2) this device must accept any interference received, including interference that may cause undesired operation.

Fig. 1.2 Example of a label with FCC ID and IC number

Approval from Industry Canada (IC)

This device complies with the Industry Canada standard RSS210.

This device complies with the RSS requirement(s) of Industry Canada for exemption from licensing regulations. Compliance with the following two conditions is a requirement of operation: (1) This device may not cause harmful interference; and (2) this device must

tolerate any interference signal, including interference that could cause undesirable operation of the device.

Intended use

The T12HP torque flange is used exclusively for torque, angle of rotation and power measurement tasks within the load limits stipulated in the specifications. Any other use is not appropriate.

Stator operation is only permitted when the rotor is installed.

The torque flange may only be installed by qualified personnel in compliance with the specifications and with the safety requirements and regulations of these mounting instructions. It is also essential to observe the applicable legal and safety regulations for the application concerned. The same applies to the use of accessories.

The torque flange is not intended for use as a safety component. Please also refer to the "Additional safety precautions" section. Proper and safe operation requires proper transportation, correct storage, siting and mounting, and careful operation.

Load-carrying capacity limits

The data in the technical data sheets must be complied with when using the torque flange. The respective specified maximum loads in particular must never be exceeded. For example, the values stated in the specifications must not be exceeded for

- Limit torque,
- Longitudinal limit force, lateral limit force or bending limit moment,
- Torque oscillation width,
- Breaking torque,
- Temperature limits,
- Limits of the electrical load-carrying capacity.

Use as a machine element

The torque flange can be used as a machine element. When used in this manner, it must be noted that, to favor greater sensitivity, the transducer is not designed with the safety factors usual in mechanical engineering. Please refer here to the section "Load-carrying capacity limits", and to the specifications.

Accident prevention

According to the prevailing accident prevention regulations, once the transducers have been mounted, a covering agent or cladding has to be fitted as follows:

- The covering agent or cladding must not be free to rotate.
- The covering agent or cladding should prevent squeezing or shearing and provide protection against parts that might come loose.

- Covering agents and cladding must be positioned at a suitable distance or be so arranged that there is no access to any moving parts within.
- Covering agents and cladding must still be attached even if the moving parts of the torque flange are installed outside peoples' movement and working range.

The only permitted exceptions to the above requirements are if the torque flange is already fully protected by the design of the machine or by existing safeguards.

Additional safety precautions

The torque flange cannot (as a passive transducer) implement any (safety-relevant) cut-offs. This requires additional components and constructive measures, for which the installer and operator of the plant is responsible. The electronics conditioning the measurement signal should be designed so that measurement signal failure does not subsequently cause damage.

The scope of supply and performance of the transducer covers only a small area of torque measurement technology. In addition, equipment planners, installers and operators should plan, implement and respond to safety engineering considerations in such a way as to minimize residual dangers. Pertinent national and local regulations must be complied with.

General dangers of failing to follow the safety instructions

The torque flange corresponds to the state of the art and is failsafe. Transducers can give rise to residual dangers if they are incorrectly operated or inappropriately mounted, installed and operated by untrained personnel.

Every person involved with siting, starting-up, operating or repairing a torque flange must have read and understood the mounting instructions and in particular the technical safety instructions.

The transducers can be damaged or destroyed by non-designated use of the transducer or by non-compliance with the mounting and operating instructions, these safety instructions or any other applicable safety regulations (BG safety and accident prevention regulations) when using the transducers. Transducers can break, particularly in the case of overloading. The breakage of a transducer can also cause damage to property or injury to persons in the vicinity of the transducer.

If the torque flange is not used according to the designated use, or if the safety instructions or specifications in the mounting and operating instructions are ignored, it is also possible that the transducer may fail or malfunction, with the result that persons or property may be affected (due to the torques acting on or being monitored by the torque flange).

Conversions and modifications

The design or safety engineering of the sensor must not be modified without our express permission. Any modification shall exclude all liability on our part for any damage resulting therefrom.

Selling on

If the torque flange is sold on, these mounting instructions must be included with the torque flange.

Qualified personnel

Qualified personnel are persons entrusted with the setup, mounting, startup and operation of the product, who have the appropriate qualifications for their function.

This includes people who meet at least one of the three following requirements:

1. Knowledge of the safety concepts of automation technology is a requirement and as project personnel, you must be familiar with these concepts.
2. As automation plant operating personnel, you have been instructed how to handle the machinery. You are familiar with the operation of the equipment and technologies described in this documentation.
3. As commissioning engineers or service engineers, you have successfully completed the training to repair the automation systems. You are also authorized to operate, ground and label circuits and equipment in accordance with safety engineering standards.

2 MARKINGS USED

2.1 Symbols attached to the transducer and/or stator

CE mark



The CE mark enables the manufacturer to guarantee that the product complies with the requirements of the relevant EC directives (the Declaration of Conformity can be found at <http://www.hbm.com/HBMdoq>).

Example of a label

Model: T12S3
FCC ID: 2ADAT-T12S3
IC: 12438A-T12S3
This device complies with part 15 of the FCC Rules. Operation is subject to the following two conditions: (1) This device may not cause harmful interference, and (2) this device must accept any interference received, including interference that may cause undesired operation.

Example of a label with model number, FCC ID and IC number. The label is attached to the device stator.





Statutory waste disposal mark



The electrical and electronic devices that bear this symbol are subject to the European waste electrical and electronic equipment directive 2002/96/EC. The symbol indicates that, in accordance with national and local environmental protection and material recovery and recycling regulations, old devices that can no longer be used must be disposed of separately and not with normal household garbage, see also Chapter 16, page 70.

2.2 The markings used in this document

Important instructions for your safety are specifically identified. It is essential to follow these instructions in order to prevent accidents and damage to property.

Symbol	Significance
 WARNING	This marking warns of a <i>potentially</i> dangerous situation in which failure to comply with safety requirements <i>can</i> result in death or serious physical injury.
 CAUTION	This marking warns of a <i>potentially</i> dangerous situation in which failure to comply with safety requirements <i>can</i> result in slight or moderate physical injury.
Notice	This marking draws your attention to a situation in which failure to comply with safety requirements <i>can</i> lead to damage to property.
 Important	This marking draws your attention to <i>important</i> information about the product or about handling the product.
 Tip	This marking indicates application tips or other information that is useful to you.
 Information	This marking draws your attention to information about the product or about handling the product.
<i>Emphasis</i> See ...	Italics are used to emphasize and highlight text and identify references to sections, diagrams, or external documents and files.

3 SCOPE OF SUPPLY

- Digital torque transducer (rotor and stator)
- T12HP mounting instructions
- Mounting kit:
- Test report
- EMI filter/toroidal strip-wound core
(if ordering separately, please use the following HBK ordering no.: 2-9290.0092)

Optional:

- Rotational speed measuring system, comprising an optical speed sensor and speed kit (slotted disc, screwdriver, threadlocker, screws)
- Protection against contact

4 OPERATION

You can find the latest version of the T12 system CD / Assistant control software on the HBM or HBK website. You can use this software to:

- check the correct installation of the torque transducer
- adjust the signal conditioning (zero balance, filters, scaling)
- protect your settings or load the factory settings
- realize and analyze measured values

Instructions for installing the T12 Assistant on your PC can be found in the “T12 Assistant control software”. The current documentation can be found on the HBM or HBK website.

Operating instructions for the T12 Assistant can be found in the program's online Help, which is called with function key F1 or via the menu bar.

You can find information on connecting to fieldbus systems in the interface description of the T12HP operating manual. The current documentation can be found on the HBM or HBK website.

5 APPLICATION

The T12HP digital torque transducer records static and dynamic torque at stationary or rotating shafts, determines the rotational speed and angle of rotation, including indicating the direction of rotation, and calculates the power. It is designed for:

- highly dynamic torque measurements when testing the power and functionality of engines and sets
- high-resolution speed and angle of rotation measurements
- fast, dynamic power measurements on engine and transmission test rigs and roll test stands

Designed to work without bearings and with contactless digital signal transmission, the torque measuring system is maintenance-free.

The torque transducer is supplied for nominal (rated) torques of 100 N·m to 10 kN·m. Maximum rotational speeds of up to 18,000 rpm (22,000 rpm) are permissible, depending on the nominal torque.

The T12HP torque transducer is reliably protected against electromagnetic interference. It is checked in accordance with harmonized European standards and/or complies with US and Canadian standards. The product carries the CE mark and the FCC label.

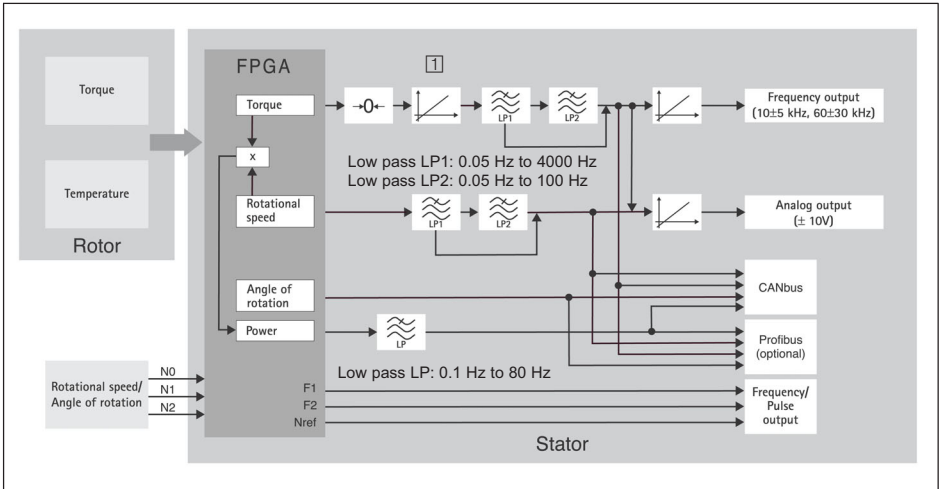

Fig. 6.1 Signal flow diagram

The torque and the temperature signal are already digitized in the rotor and transmission is noise-free.

The torque signal can be zeroed $\rightarrow 0 \leftarrow$, scaled \nearrow (2-point scaling) and filtered via two low passes (LP1 and LP2). Further scaling of the frequency output and the analog output is then possible.

! Important

Scaling at position 1 (see Fig. 6.1) changes the internal calibration of the torque transducer.

The rotational speed signal can be filtered and also scaled for the analog output.

The angle of rotation signal, the power signal (low-pass filter LP) and the temperature signal are only available on the fieldbuses.

The torque signal and the rotational speed signal can be filtered via two low passes connected in series, with the filter outputs also being available separately.

The scaled, unfiltered torque signal is used to calculate the power. The resultant, highly-dynamically calculated power signal is filtered via a further low pass.

For settings over 100 Hz (torque low-pass filter 1 only), phase delay compensation is run for the angle of rotation signal. This ensures that torque and angle of rotation values that are measured simultaneously are also output simultaneously.

Two pulse series offset by 90° are available as RS-422-compatible signals for rotational speed and angle of rotation.

7 STRUCTURE AND MODE OF OPERATION

The torque transducer comprises two separate parts: the rotor and the stator.

Strain gages (SG) to determine the torque are installed on the rotor. Carrier frequency technology (19.2 kHz carrier frequency) is used for the strain gage analysis. The rotor temperature is measured at two measuring points and averaged.

The electronics for transmitting the bridge excitation voltage and the measurement signal are located centrally in the rotor. The coils for contactless transmission of the excitation voltage and measurement signal are located on the outer circumference of side A of the rotor. The signals are sent and received by the transmitter head. The transmitter head is mounted on the stator, which houses the electronics for voltage adaptation and signal conditioning.

Connector plugs for the inputs and outputs are located on the stator (see Section 10.3 for the pin assignment). The transmitter head encloses the rotor over a segment of approx. 120° and should be mounted concentrically around the rotor (see Chapter 8).

In the case of the rotational speed measuring system option, the speed sensor is mounted on the stator, the customer attaches the associated slotted disc to the rotor. The optical rotational speed measurement works on the infrared transmitted light principle.

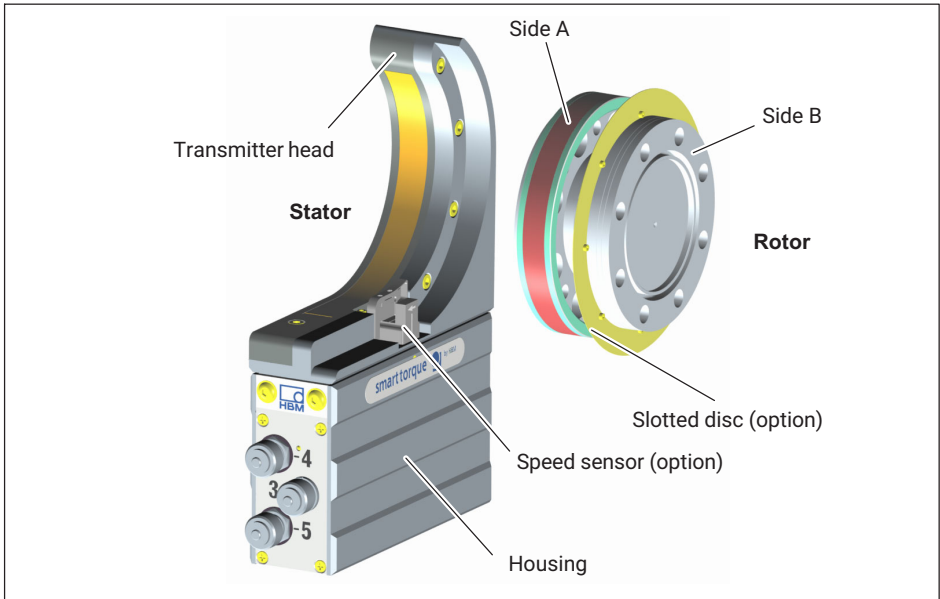

Fig. 7.1 Mechanical structure, exploded view

8 MECHANICAL INSTALLATION

8.1 Important precautions during installation

Notice

A torque flange is a precision measurement element and therefore needs careful handling. Dropping or knocking the transducer may cause permanent damage. Make sure that the transducer cannot be overloaded, including while it is being mounted.

- Handle the transducer with care.
- Check the effect of bending moments, critical rotational speeds and natural torsional vibrations, to prevent the transducer being overloaded by resonance sharpness.
- Make sure that the transducer cannot be overloaded.

WARNING

There is a danger of the transducer breaking if it is overloaded. This can cause danger for the operating personnel of the system in which the transducer is installed.

Implement appropriate safety measures to avoid overloads and to protect against resulting dangers.

- Use a threadlocker (medium strength, e.g. LOCTITE) to glue the screws into the counter thread to exclude prestressing loss due to screw slackening, in the event of alternating loads.
- Comply with the mounting dimensions to enable correct operation.

An appropriate shaft flange enables the T12HP torque flange to be mounted directly. It is also possible to mount a joint shaft or relevant compensating element directly on the rotor (using an intermediate flange when required). Under no circumstances should the allowed limits specified for bending moments, lateral and axial forces be exceeded. Due to the T12HP torque flange's high torsional stiffness, dynamic shaft train changes are kept to a minimum.

Important

Even if the unit is installed correctly, the zero point adjustment made at the factory can shift by up to approx. 3% of the characteristic value. If this value is exceeded, we advise you to check the mounting conditions. If the residual zero drift when the unit is removed is greater than 1% of the rated output, please send the transducer back to the Darmstadt factory for testing.

8.2 Conditions on site

The T12HP torque transducer is protected to IP54 according to EN 60529. Protect the transducer from coarse dirt, dust, oil, solvents and moisture. During operation, the prevailing safety regulations for the security of personnel must be observed (see “Safety instructions”).

There is wide ranging compensation for the effects of temperature on the output and zero signals of the T12HP torque transducer (see specifications on page 71). This compensation is carried out at static temperatures. This guarantees that the circumstances can be reproduced and the properties of the transducer can be reconstructed at any time.

If there are no static temperature ratios, for example, because of the temperature differences between flange A and flange B, the values given in the specifications can be exceeded. Then for accurate measurements, you must ensure static temperature ratios by cooling or heating, depending on the application. As an alternative, check thermal decoupling, by means of heat radiating elements such as multiple disc couplings.

8.3 Mounting position

The transducer can be mounted in any position. With clockwise torque, the output frequency is 10 to 15 kHz (Option 5, code DF1/DU2: 60 kHz to 90 kHz). In conjunction with HBK amplifiers or when using the voltage output, a positive output signal (0 V to +10 V) is present.

With counterclockwise torque, the output frequency is 5 to 10 kHz (Option 5, code DF1/DU2: 30 kHz to 60 kHz).

In the case of the rotational speed measuring system, an arrow is attached to the head of the sensor to clearly define the direction of rotation. When the transducer rotates in the direction of the arrow, a positive rotational speed signal is output.

8.4 Information on the slotted screw (with rotational speed measuring systems only)

If the sensor is ordered with the rotational speed measuring system option, the rotor is supplied with the pre-assembled slotted disk. A speed kit (material number: 2-9289.20XX) is available for replacement of the slotted disk, e.g. if damaged. This can be ordered separately.

Material number vs. measurement range:

2-9289.2049: T12/T12HP 100-200 Nm

2-9289.2050: T12/T12HP 500 Nm-1 kNm

2-9289.2051: T12/T12HP 2-3 kNm

2-9289.2321: T12/T12HP 5 kNm

2-9289.2325: T12/T12HP 10 kNm

The speed kit contains a slotted disk, the required screws including threadlocker and a suitable screwdriver.

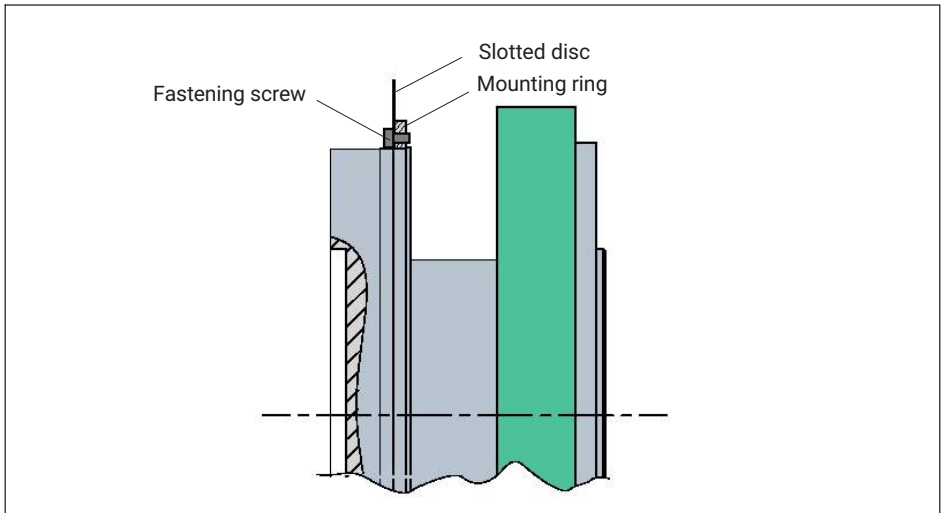

Fig. 8.1 Installing the slotted disc



Important

At all stages of the mounting operation, be careful not to damage the slotted disc!

Installation sequence

1. Push the slotted disc onto the mounting ring and align the screw holes.
2. Apply some of the threadlocker to the screw thread and tighten the screws (tightening torque <math>< 0.15 \text{ N}\cdot\text{m}</math>).

8.5 Installing the rotor



Tip

Usually the rotor type plate is no longer visible after installation. This is why we include with the rotor additional stickers with the important characteristics, which you can attach to the stator or any other relevant test-bench components. You can then refer to them whenever there is anything you wish to know, such as the shunt signal. To explicitly assign the data, the identification number and the size are engraved on the rotor flange, where they can be seen from outside.

Notice

Make sure during installation that you do not damage the measuring zone marked in Fig. 8.2 by using it to support tools or knocking tools against it when tightening screws, for example. This can damage the transducer and produce measurement errors, or even destroy the transducer.

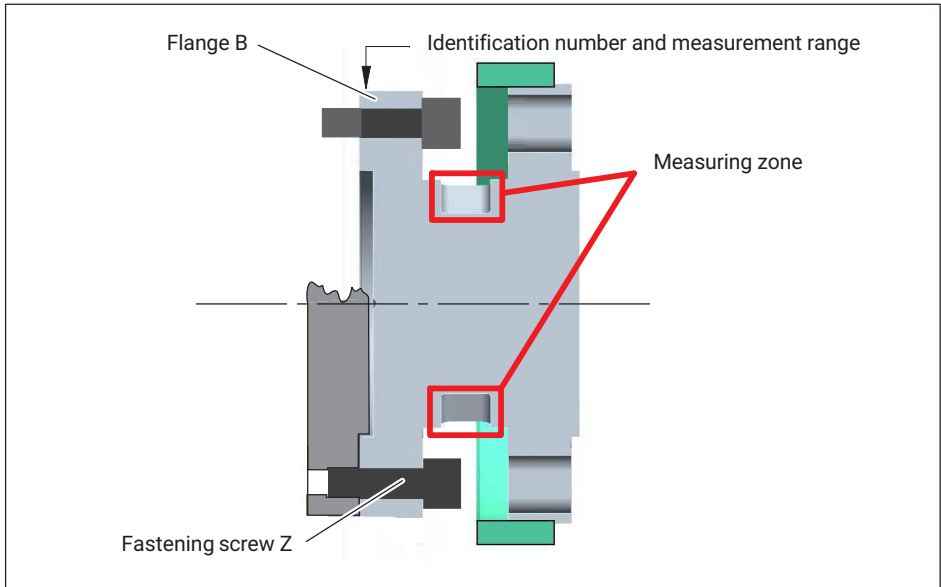

Fig. 8.2 Screw connections, flange B

1. Prior to installation, clean the plane faces of the transducer flange and the counter flange.
For safe torque transfer, the surfaces must be clean and free from grease. Use a piece of cloth or paper soaked in solvent. When cleaning, make sure that you do not damage the transmitter coils.
2. For the flange B screw connections, use hexagon socket screws *DIN EN ISO 4762* of *property class 10.9* (measurement ranges $3 \text{ kN} \cdot \text{m}$ to $10 \text{ kN} \cdot \text{m}$: 12.9) of the appropriate length (depending on the connection geometry, see *Tab. 8.1*).
We recommend *DIN EN ISO 4762* socket head cap screws, blackened, smooth-headed, permitted size and shape variance as per *DIN ISO 4759, Part 1*, product class A.
3. First tighten all the screws crosswise with 80% of the prescribed tightening torque (*Tab. 8.1*), then tighten again crosswise with the full tightening torque.

4. There are relevant tapped holes on flange A for continuing the shaft train mounting. Again use screws of property class 10.9 (measurement ranges 3 kN·m to 10 kN·m: 12.9) and tighten them with the prescribed torque, as specified in *Tab. 8.1*.

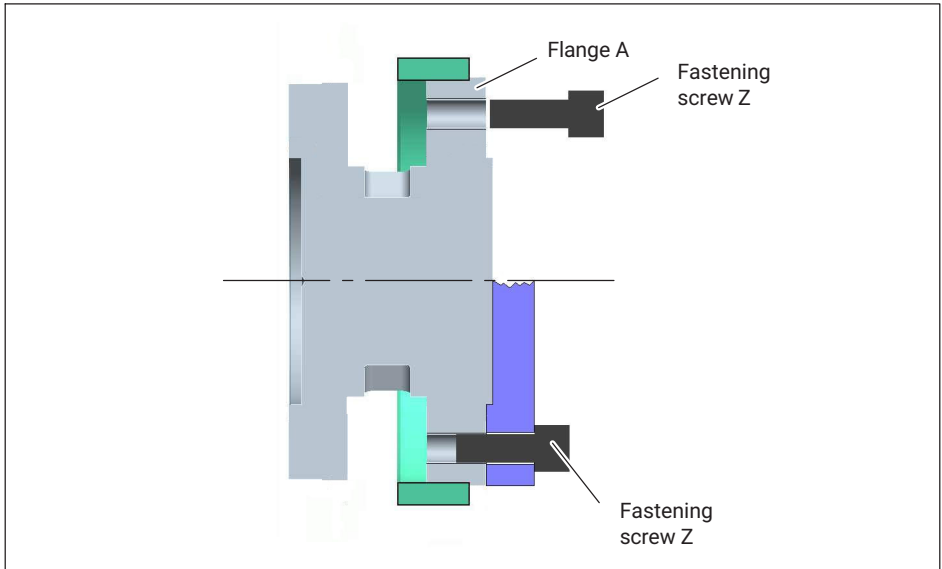

Fig. 8.3 Screw connections, flange A

! Important

Use a threadlocker (medium strength, e.g. LOCTITE) to glue the screws into the counter thread to exclude prestressing loss due to screw slackening, in the event of alternating loads.

Notice

Comply with the minimum thread reach as per *Tab. 8.1*.
The maximum thread reach must be selected so that the counter flange is not touched. Otherwise significant measurement errors may result from a torque shunt, or the transducer may be damaged.

Measurement range N·m	Fastening screws		Prescribed tightening moment N·m	Minimum thread reach mm	
	Z ¹⁾	Property class			
100/200	M8	10.9	34	1,2 x d ²⁾	
500	M10		67		
1 k	M10		67		
2 k	M12		115		
3 k	M12	12.9	135		
5 k	M14		220		
10 k	M16		12.9		340

1) DIN EN ISO 4762; black/oiled/ $\mu_{\text{tot}} = 0.125$

2) d = screw diameter in mm

Tab. 8.1 Fastening screws



Important

Dry screw connections can result in different and higher coefficients of friction (see VDI 2230, for example). This means a change to the required tightening torques. The required tightening torques can also change if you use screws with a surface or property class other than that specified in Tab. 8.1, as this affects the coefficient of friction.

8.6 Fitting the protection against contact (option)

The protection against contact comprises two side parts and two cover plates. It is screwed onto the stator housing.



Important

Use a threadlocker (medium strength, e.g. LOCTITE) to glue the screws into the counter thread.

1. Remove the side cover plates on the stator housing (see Fig. 8.4.)

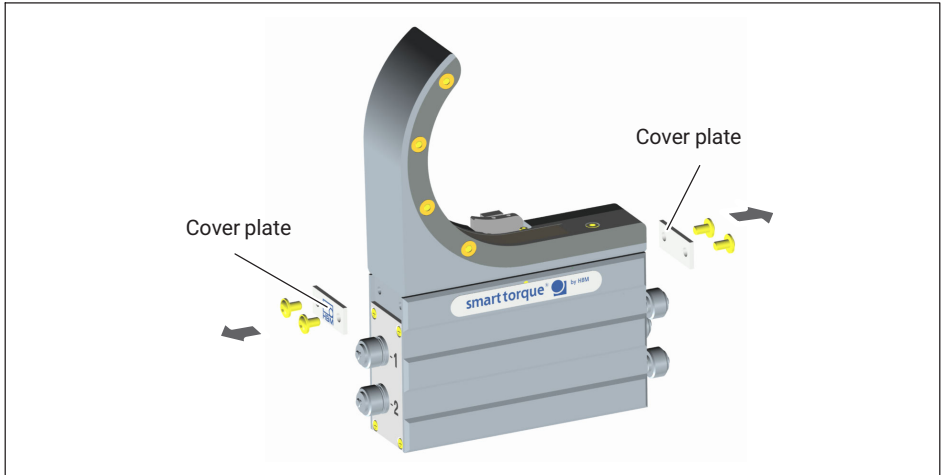

Fig. 8.4 Cover plates on the stator housing

2. For $500 \text{ N} \cdot \text{m}$ to $3 \text{ kN} \cdot \text{m}$ measurement ranges and retrospective protection against contact orders only: some of the tapped holes for the locking screws are covered by attached film. Make a semicircular cutout in the film here, at least 6 mm in radius (e.g. with a cutter, see Fig. 8.5).
Now remove the threaded pins from the tapped holes on both sides of the stator.

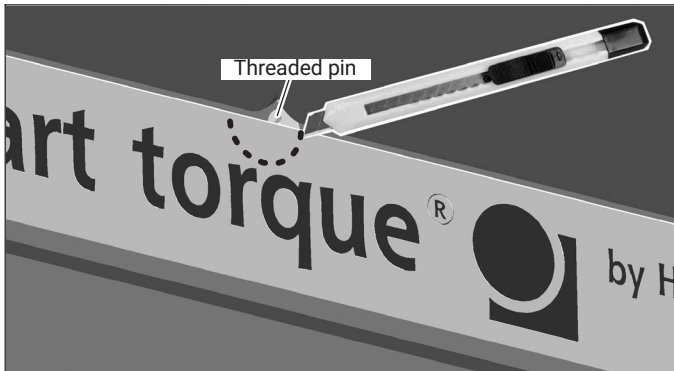

Fig. 8.5 Cut out the film

3. For $5 \text{ kN} \cdot \text{m}$ and $10 \text{ kN} \cdot \text{m}$ measurement ranges only: remove the threaded pins from the tapped holes on both sides of the stator. Screw the spacing bolt into the tapped hole on the side of the speed sensor (see Fig. 8.6).

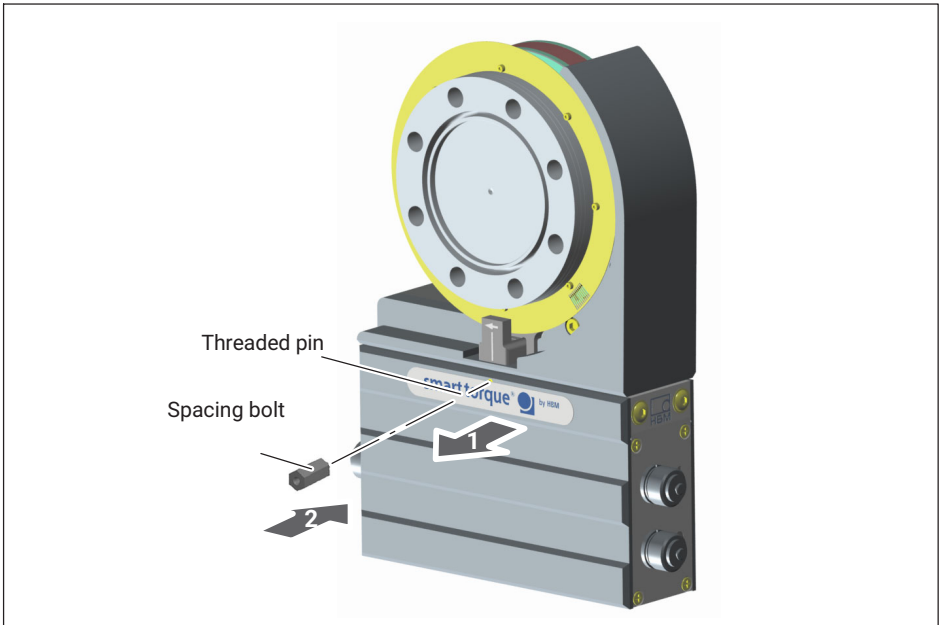

Fig. 8.6 Fitting the spacing bolt (for $5 \text{ kN} \cdot \text{m}$ and $10 \text{ kN} \cdot \text{m}$ only)

- Screw the cover plates onto the side parts (hexagon socket screws, 2 AF; tightening torque $M_A = 1 \text{ N} \cdot \text{m}$). Make sure that the cover plate with the cutouts is fitted on the side with the countersunk holes! (See Fig. 8.7.)

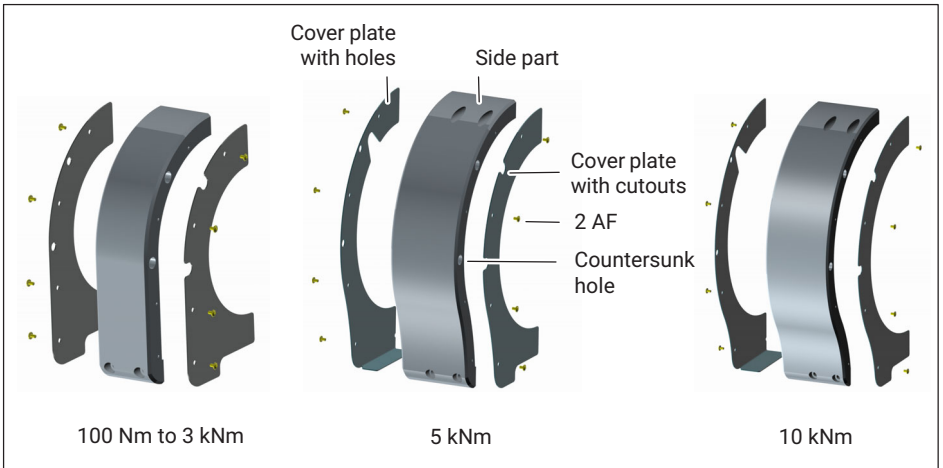

Fig. 8.7 Fitting the cover plates

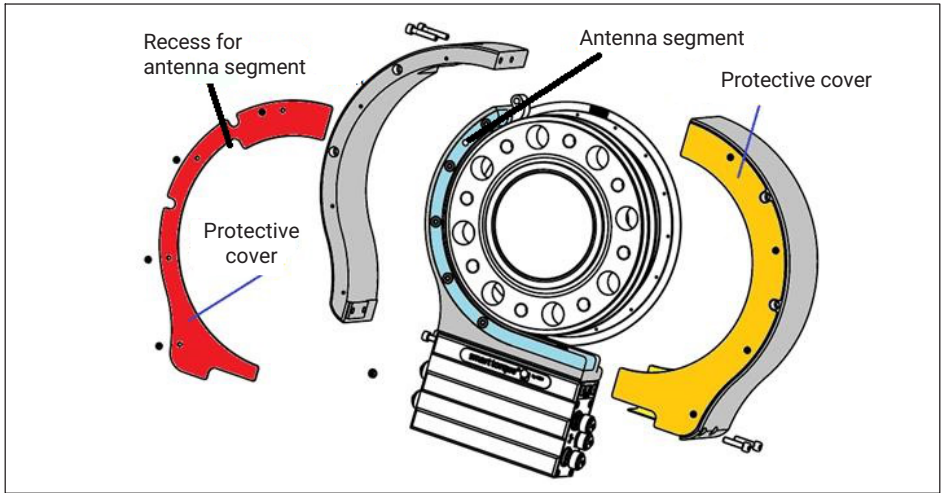

Fig. 8.8 Protective cover T12HP



Important

The cover plate (shown here in red) with the recess should only be used for the side on which the segment antenna (blue) is positioned.



Important

With the $5 \text{ kN} \cdot \text{m}$ and $10 \text{ kN} \cdot \text{m}$ measurement ranges, the cover plates of the speed sensor side must be angled at the bottom and fitted as shown in Fig. 8.9.

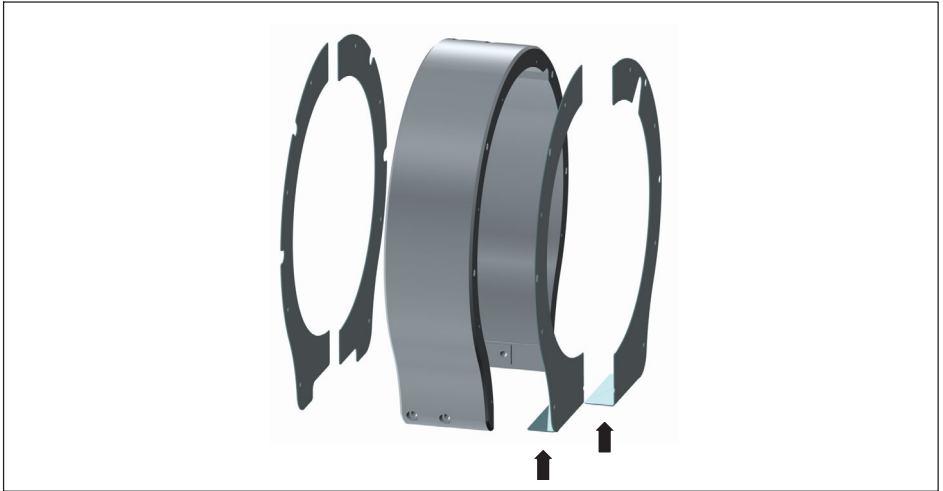

Fig. 8.9 Angled cover plates (5 kN · m and 10 kN · m measurement ranges)

5. Mount each of the pre-assembled side parts onto the stator housing with two M6x25 (5 AF) hexagon socket screws. Hand-tighten the screws.
6. Screw the side parts together at the top, hand-tight (2 hexagon socket screws M6x30; 5 AF).

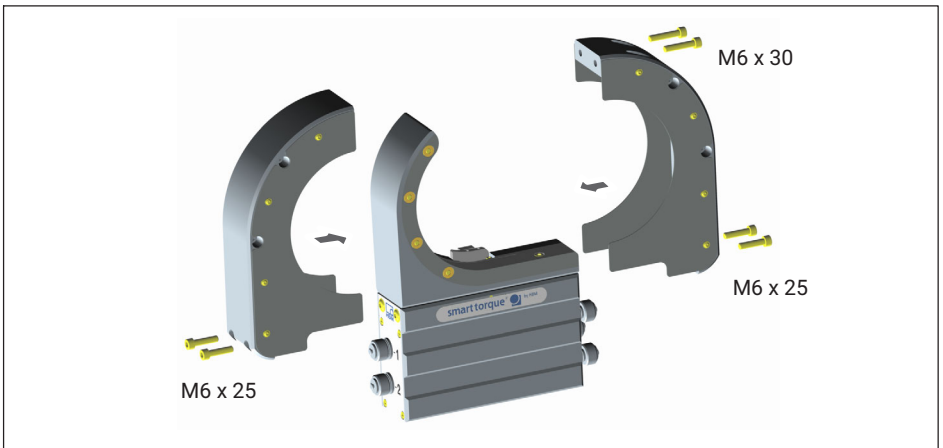

Fig. 8.10 Fitting the two halves of the protection against contact

7. Align the protection against contact in such a way that its end face is parallel to the stator housing.

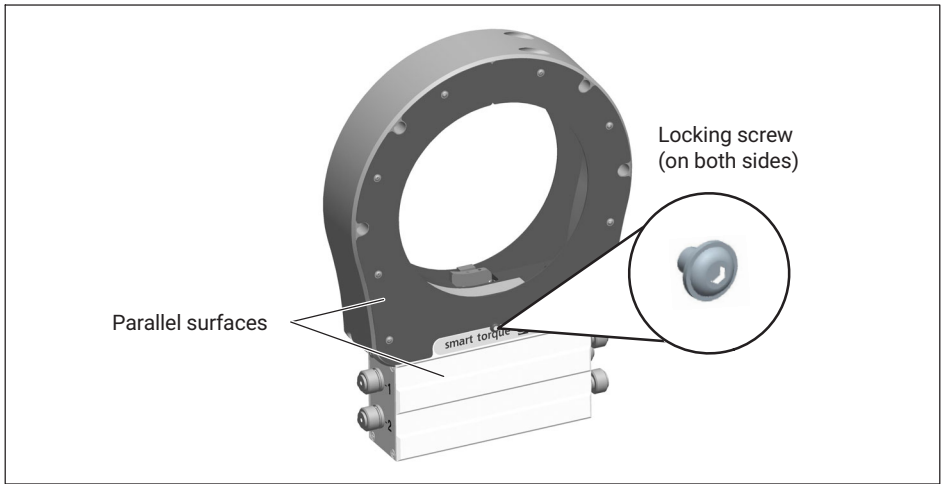

Fig. 8.11 Check for parallelism

8. Now tighten all the screws with a tightening torque M_A of $14 \text{ N} \cdot \text{m}$.
9. Screw in the cover plate locking screws and tighten them with a torque of $2 \text{ N} \cdot \text{m}$.

8.7 Installing the stator

On delivery, the stator has already been installed and is ready for operation. There are four tapped holes on the base of the stator housing for mounting the stator. Externally, two with a metric M6 thread, internally, two with a UNF 1/4" thread (closed with a plastic threaded pin).

For mounting with a metric thread, we recommend using two DIN EN ISO 4762 socket head cap screws with hexagon sockets of property class 10.9 of the appropriate length (depending on the connection geometry – not included among the items supplied; tightening torque = $14 \text{ N} \cdot \text{m}$).



Tip

Allow for possible adjustment when aligning the stator to the rotor (e.g. provide slotted holes).

The stator can be mounted radially in any position (for example, "upside down" installation is possible). You can also install the stator over the protection against contact (option), see Section 8.7.3.

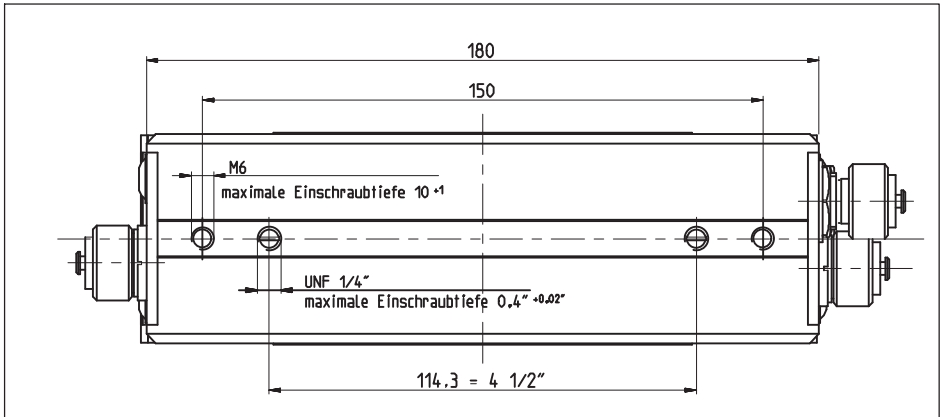

Fig. 8.12 Mounting holes in the stator housing (viewed from below)

We always recommend supporting the stator of the T12HP torque transducer to hold it in place. Fig. 8.13 shows as an example the mounting of an angle bracket, without protection against contact.

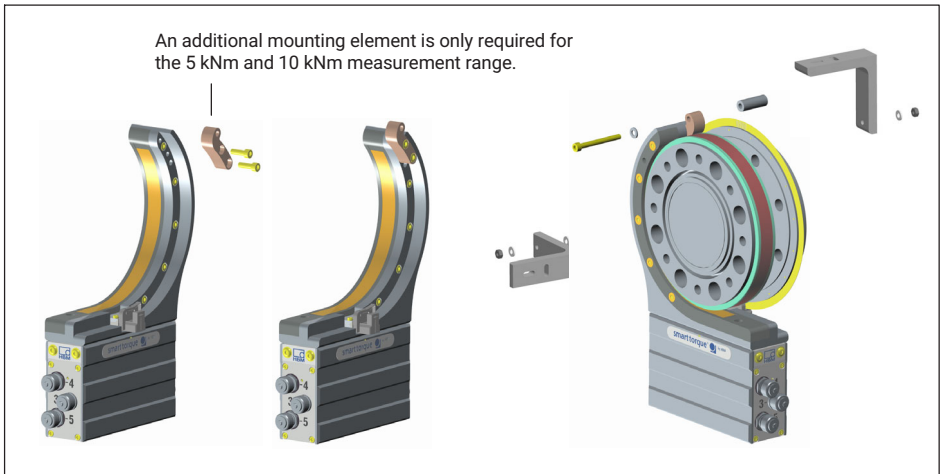

Fig. 8.13 Supporting the stator without protection against contact

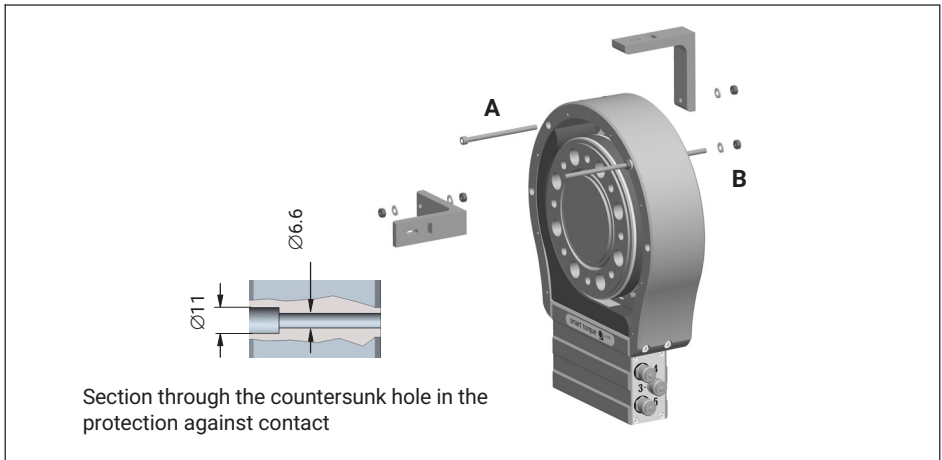

Fig. 8.14 Supporting the stator with protection against contact

8.7.1 Preparing with the mounting kit (incl. among the items supplied)

The supplied mounting kit contains self-adhesive spacers, to make it easier for you to align the stator to the rotor.

Use the spacers to align the rotor and the stator radially and axially.

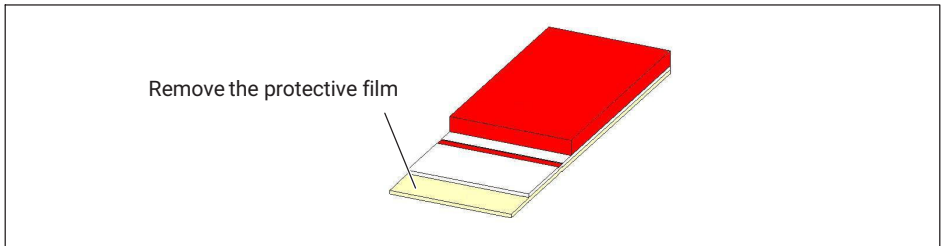

Fig. 8.15 Mounting kit spacer

Radial alignment with spacers

The spacers should preferably be attached to the transmitter head offset by 90° , as shown in *Fig. 8.16*. If your stator is equipped with a rotational speed measuring system, you must either shorten the spacer to an appropriate length or attach it next to the rotational speed measuring system, slightly offset.

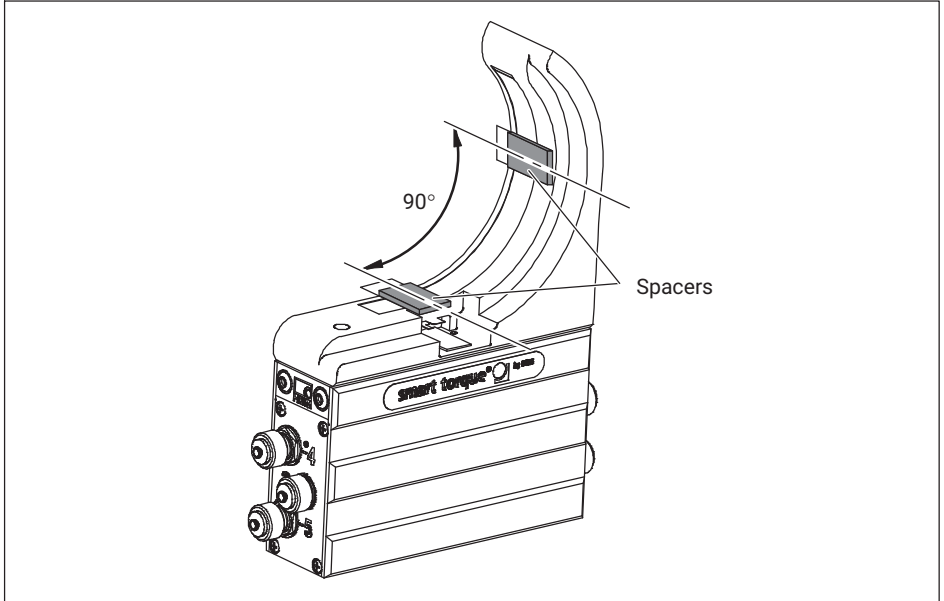

Fig. 8.16 Radial position of the spacers

Axial alignment with spacers

The red line on the spacers is used for axial alignment. Align the spacer in such a way that the outer edge of the transmitter head is in line with the red line (see Fig. 8.17).

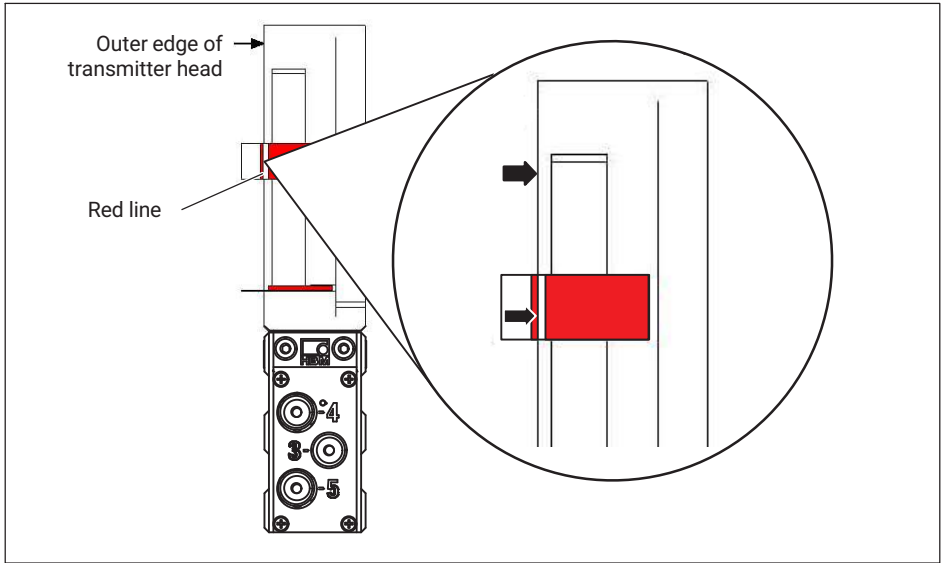

Fig. 8.17 Axial position of the spacers

Now remove the protective film and attach the spacers to the transmitter head, as described.



Important

Remove the spacers after installation.

8.7.2 Aligning the stator

1. Position the stator on an appropriate mounting base in the shaft train, so that there are sufficient opportunities for horizontal and vertical adjustments to be made.
2. Should there be any misalignment in height, compensate for this by inserting adjusting washers.
3. Initially, the fastening screws should only be hand-tight.
4. Use the spacers to radially align the stator to the rotor.
5. Use the spacers to axially align the stator to the rotor. The rotor should be in line with the edge of the red spacer, see Fig. 8.18.

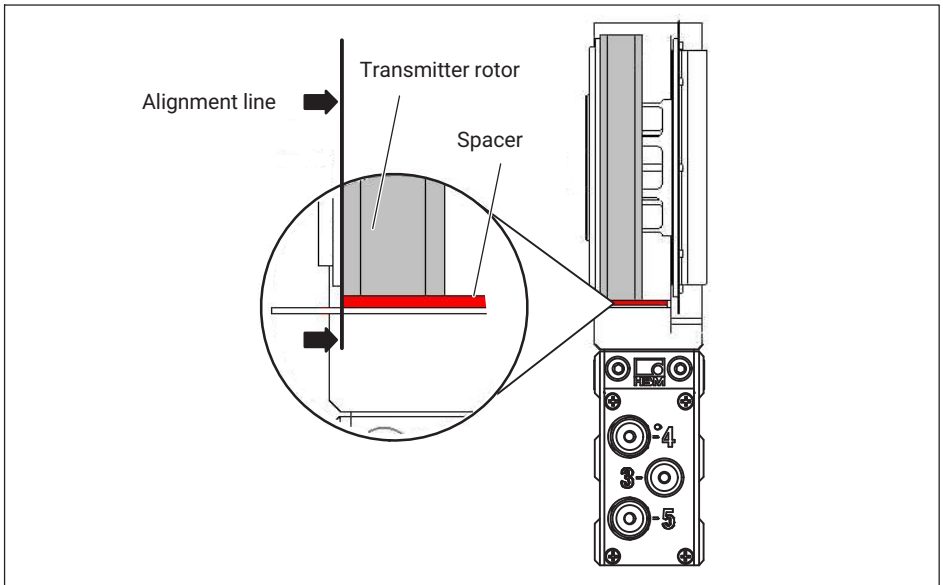

Fig. 8.18 Axial alignment to the rotor

6. Connect the power line (plug 1 or plug 3). Watch the LED to the right of plug 4. The stator is correctly aligned when the LED successively
 - flashes red for about 10 seconds
 - flashes yellow for about 10 seconds
 - then stays permanently green (CAN bus) or yellow or green (PROFIBUS).



Information

When data are being exchanged via the CAN bus or the PROFIBUS, the LED flashes green.

You can also use the T12HP Assistant to check for the correct alignment. The LED must stay green in the "Rotor clearance setting mode".

7. Now fully tighten the fastening screws (tightening torque $14 \text{ N} \cdot \text{m}$).
8. Remove the spacers, by first removing the adhesive strip and then the red plastic strip.
9. Make sure that the air gap between rotor and stator is free from electrically conductive and other foreign matter.

8.7.3 Stator installation over the protection against contact (option)

You can also axially flange the stator over the protection against contact (material: aluminum). Holes are provided in the side parts of the protection against contact for this purpose. For this mounting, we recommend M6 socket head cap screws with hexagon sockets in accordance with DIN EN ISO 4762; black/oiled/ $\mu_{\text{tot}} = 0.125$, of the appropriate length.

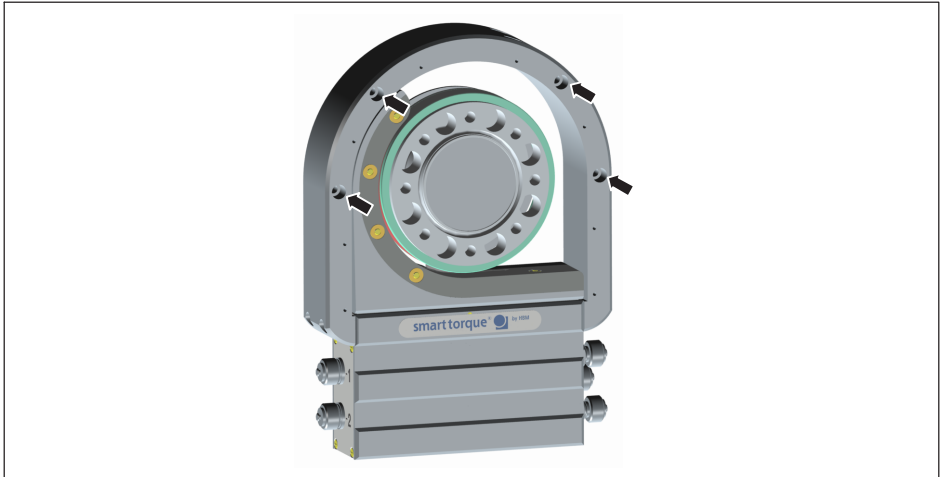
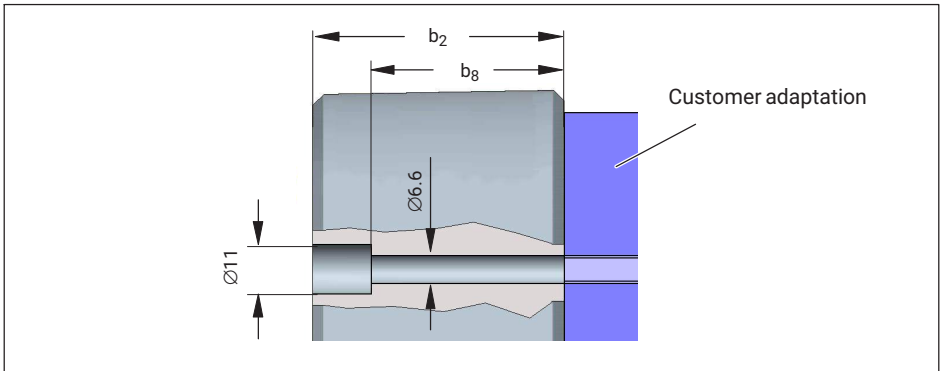

Fig. 8.19 Mounting holes in the protection against contact



Measurement range	Dimensions in mm (1 mm = 0.03937 inches)	
	b_2	b_8
100 N·m to kN·m	56	43
5 kN·m	78	65
10 kN·m	86	73

Tab. 8.2 Mounting hole dimensions

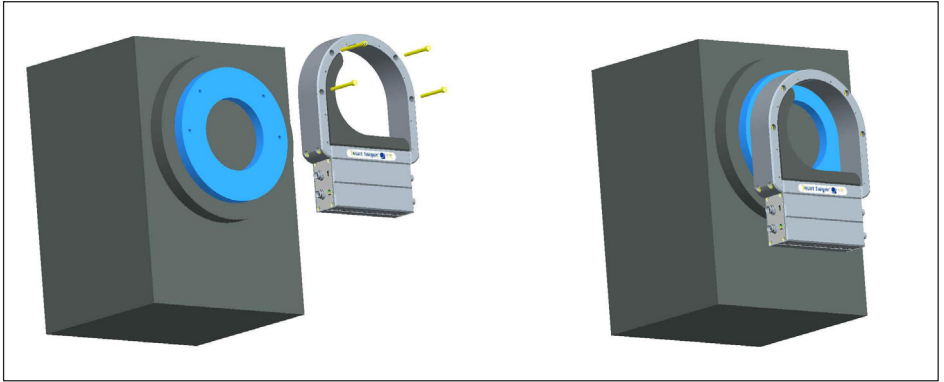

Fig. 8.20 Face-mounting on the customer side engine shielding

8.8 Optical measuring system for speed/angle of rotation (option)

As the stator with the optical speed sensor only partially encloses the slotted disc, if there is sufficient space available for installation, you can subsequently move the stator tangentially over the ready-mounted rotor.

For the perfect measuring mode, the slotted disc of the rotational speed measuring system must rotate at a defined position in the sensor pickup.

8.8.1 Axial alignment

There is a mark (alignment line) in the sensor pickup for axial alignment. When installed, the slotted disc should be exactly above this alignment line. Divergence of up to ± 2 mm is permissible in measuring mode (total of static and dynamic shift).

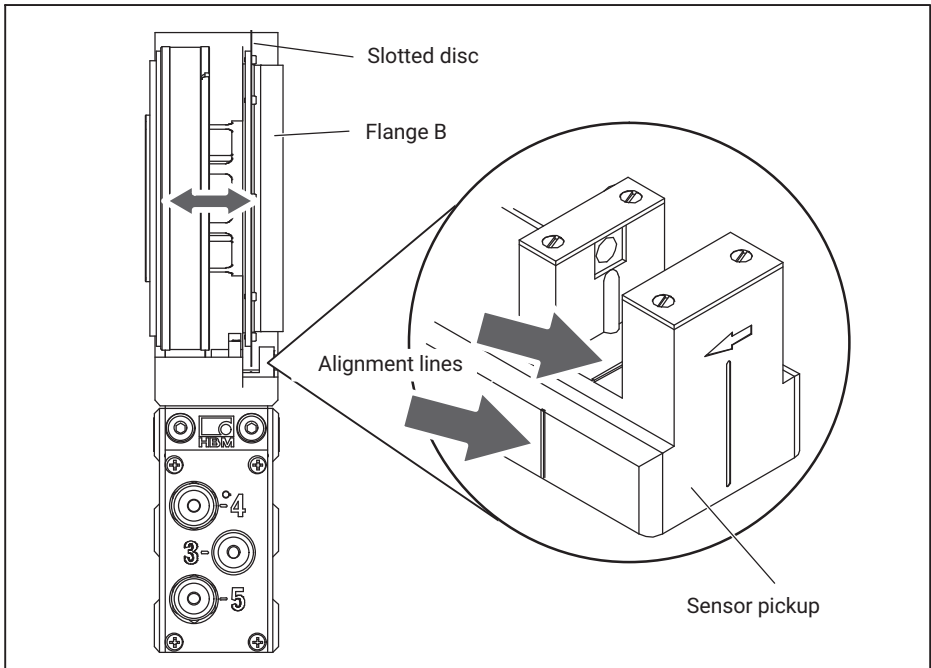

Fig. 8.21 Position of the slotted disc in the speed sensor

8.8.2 Radial alignment

The rotor axis and the optical axis of the speed sensor must be along a line perpendicular to the stator platform. A conical machined angle (or a colored mark) in the center of flange B and a vertical marker line on the sensor pickup serve as alignment aids.

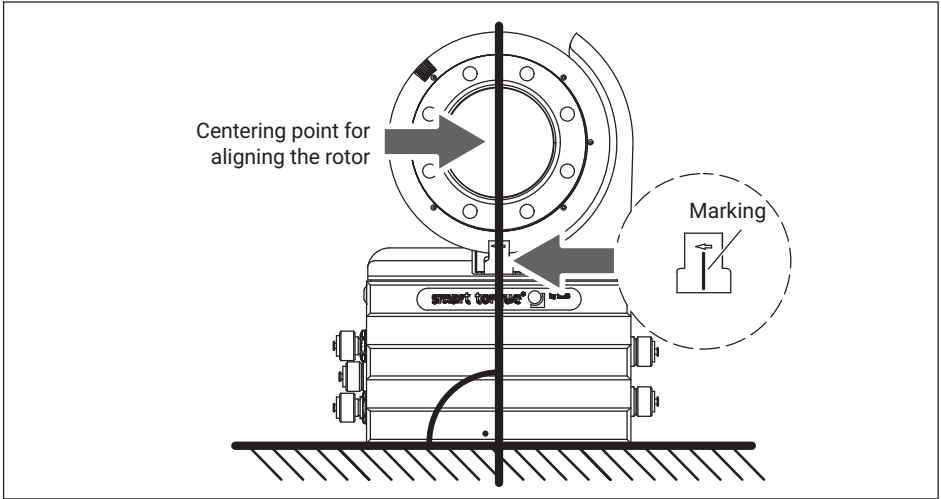

Fig. 8.22 Alignment markings on rotor and stator

Connect the power line (plug 1).

Switch the LED display mode of the T12HP Assistant to "optical speed system" setting mode and turn the rotor. Watch the LED to the right of plug 4; this must stay green if the setting is correct (*also see Section 9.3*).

! **Important**

Angle of rotation measurement is not suitable for static and quasi-static applications!

9 LED STATUS DISPLAY

The LED in the stator housing (next to device plug 4) has three display modes: Standard (measuring mode), rotor clearance setting mode and optical speed system setting mode.

9.1 Measuring mode operation

LED color	Significance
Flashing green (fast)	CAN device: service data objects (SDO) are being transmitted
Flashing green	CAN device has operational status
Green	For PROFIBUS option only: data exchange is taking place ¹⁾⁾
Flashing yellow (slow)	Rotor communication is taking place
Yellow	For PROFIBUS option only: searching for the baud rate, or parameterization or configuration are taking place, or there is no data exchange taking place ¹⁾⁾
Flashing red	Overflow in the measured value (amplifier input, measured value ovfl.), frequency or analog output
Red	Error situation

¹⁾ When PROFIBUS option is present: messages to the PROFIBUS take precedence over messages to the CAN bus.

9.2 Rotor clearance setting mode operation

LED color	Significance
Green	Rotor/stator alignment is OK
Yellow	Rotor/stator alignment is borderline
Red	Rotor/stator alignment is not OK

9.3 Rotational speed measuring system setting mode operation

LED color	Significance
Green	The position of the two sensors is OK, the signals (F1/F2) are phase-shifted by 90° or 270° and can be correctly evaluated
Yellow	The phase relation of the two sensor signals is not perfect, there is a variation of 10° to 30°
Red	The phase relation of the two sensor signals is not correct, there is a variation of more than 30°

For more information on setting mode, look in the T12HP Assistant online Help.

10.1 General information

Detailed instructions for connecting the T12HP to the CAN bus or the PROFIBUS can be found in the “T12 CAN bus/PROFIBUS” interface description (in pdf format) on the T12 system CD.

To make the electrical connection between the torque transducer and the measuring amplifier, we recommend using shielded, low-capacitance measurement cables from HBK.

With extension cables, make sure that there is a proper connection with minimum contact resistance and good insulation. All plug connections or swivel nuts must be fully tightened.

Do not route the measurement cables parallel to power lines and control circuits. If this cannot be avoided (in cable pits, for example), maintain a minimum distance of 50 cm and also draw the measurement cable into a steel tube. Avoid transformers, motors, contactors, thyristor controls and similar stray-field sources.



Important

Transducer connection cables from HBK with attached plugs are marked in accordance with their intended purpose (Md or n). When cables are shortened, inserted into cable ducts or installed in control cabinets, this marking can be lost or hidden. If this is the case, it is essential for the cables to be re-labeled!



Information

Cables and plugs for connectors 1, 2 and 3 are compatible with torque flange T10XX, T40XX.

10.1.1 Using the EMI filter/toroidal strip-wound core, for applications in the USA and Europe

To suppress high frequencies, use an EMI filter/toroidal strip-wound core for the cable through which the transducer is supplied. For use in the USA and in the EU, work with 5 cable windings for the 100 Nm and 200 Nm measurement ranges. Apply 3 cable windings for all other measurement ranges.

The mounting must be implemented with cable ties that are suitable for the particular application. Choose an area for the mounting that is not exposed to any mechanical stress (i.e. no unwelcome vibrations, etc.).

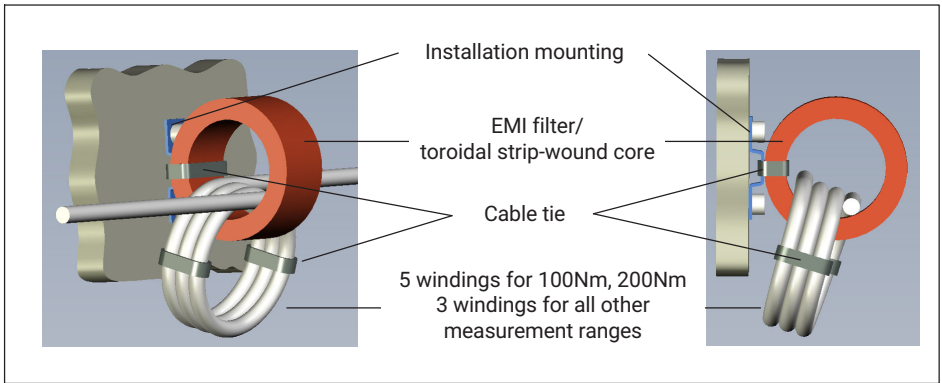

Fig. 10.1 EMI filter/toroidal strip-wound core installation example

i Information

Take into account approx. 40 cm (3 windings), or approx. 70 cm (5 windings) of additional cable length to install the EMI filter/toroidal strip-wound core.

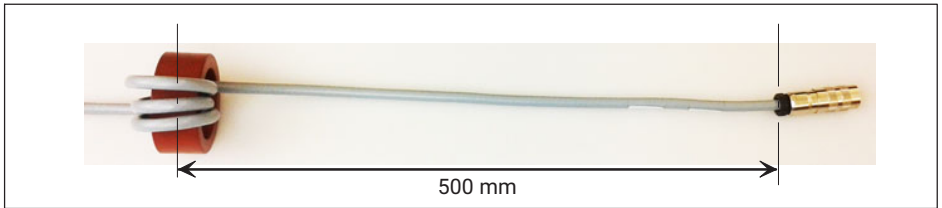

Fig. 10.2 Max. distance between the EMI filter/toroidal strip-wound core and the connector

If the EMI filter/toroidal strip-wound core has to be removed for some reason (e.g. for maintenance work), it must be re-attached to the cable afterwards. Only use an EMI filter/toroidal strip-wound core of the following type:

HBK ordering no.: 2-9290.0092

Type: Vitroperm R

Model No.: T60006-22063W517

Size: outside diameter x internal diameter x height = 63 mm x 50 mm x 25 mm

The mounting option shown in Fig. 10.1 and Fig. 10.2 needs an EMI filter/toroidal strip-wound core as well as the cable. Use additional mountings to avoid stress on the connector from the additional weight of the cable.



Important

For applications in the USA, the use of an EMI filter/toroidal strip-wound core on the cable through which the transducer is supplied (plug 1 or plug 3) is mandatory, to ensure compliance with FCC Rules. The same applies to applications in the EU, for compliance with the relevant EMC requirements.

10.2 Shielding design

The cable shield is connected in accordance with the Greenline concept. This encloses the measurement system (without the rotor) in a Faraday cage. It is important that the shield is laid flat on the housing ground at both ends of the cable. Any electromagnetic interference active here does not affect the measurement signal. Special electronic coding methods are used to protect the purely digital signal transmission between the transmitter head and the rotor from electromagnetic interference.

In the case of interference due to potential differences (compensating currents), supply voltage zero and housing ground must be disconnected on the amplifier and a potential equalization line established between the stator housing and the amplifier housing (copper conductor, 10 mm² wire cross-section).

If potential differences arise between the rotor and the stator on the machine, perhaps due to unchecked leakage, and this causes interference, it can usually be overcome by connecting the rotor directly to ground by a wire loop, for instance. The stator should be fully grounded in the same way.

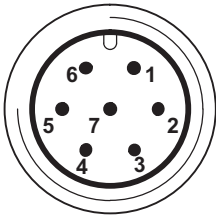

10.3 Pin assignment

Assignment for plug 1 - supply voltage and frequency output signal



Device plug

Top view

Plug pin	Assignment	KAB153 Color code	KAB149 D-SUB Plug pin	KAB178 ¹⁾ HD-SUB plug pin
1	Torque measurement signal (frequency output; 5 V ²⁾)	wh	13	5
2	Supply voltage 0 V 	bk	5	-
3	Supply voltage 18 V ... 30 V	bu	6	-
4	Torque measurement signal (frequency output; 5 V ²⁾)	rd	12	10
5	Measurement signal 0 V; symmetrical 	gy	8	6
6	Shunt signal trigger 5 V ... 30 V	gn	14	15
7	Shunt signal 0 V 	gy	8	6
	Shield connected to housing ground			

1) Bridge between 4 + 9

2) RS-422 complementary signals; with cable lengths exceeding 10 m, we recommend using a termination resistor R = 120 ohms between the (wh) and (rd) wires.



Important

If power supplied to the device via plug 1, high frequencies must be filtered out. For applications in the USA, the use of an EMI filter/toroidal strip-wound core on the mains cable is mandatory, to ensure compliance with FCC Rules. The same applies to applications in the EU, for compliance with the relevant EMC requirements.

Notice

Torque transducers are only intended for operation with a DC supply voltage (safety extra low voltage), see page 48.

Assignment for plug 2 - rotational speed measuring system

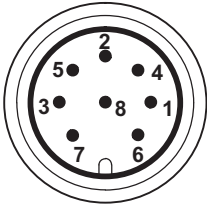

Device plug

Top view

		KAB154	KAB150	KAB179 ¹⁾
Plug pin	Assignment	Color code	D-SUB plug pin	HD-SUB plug pin
1	Speed measurement signal ²⁾ (pulse string, 5 V; 0°)	rd	12	10
2	Not in use	bu	-	-
3	Speed measurement signal ²⁾ (pulse string, 5 V; 90° phase shifted)	gy	15	8
4	Not in use	bk	-	-
5	Not in use	vt	-	-
6	Speed measurement signal ²⁾ (pulse string, 5 V; 0°)	wh	13	5
7	Speed measurement signal ²⁾ (pulse string, 5 V; 90° phase shifted)	gn	14	7
8	Supply voltage zero	bk/bu ³⁾	8	6
	Shield connected to housing ground			

¹⁾ Bridge between 4 + 9

²⁾ RS-422 complementary signals; with cable lengths exceeding 10 m, we recommend using a termination resistor of R = 120 ohms.

³⁾ For KAB163 / KAB164 color code brown (bn)

Assignment for plug 2 - rotational speed measuring system with reference pulse

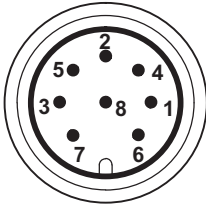

Device plug

Top view

		KAB164	KAB163	KAB181 ¹⁾
Plug pin	Assignment	Color code	D-SUB plug pin	HD-SUB plug pin
1	Speed measurement signal ²⁾ (pulse string, 5 V; 0°)	rd	12	10
2	Reference signal (1 pulse/revolution, 5 V) ²⁾	bu	2	3
3	Rotational speed measurement signal ²⁾ (pulse string, 5 V; 90° phase shifted)	gy	15	8
4	Reference signal (1 pulse/revolution, 5 V) ²⁾	bk	3	2
5	Not in use	vt	-	-
6	Speed measurement signal ²⁾ (pulse string, 5 V; 0°)	wh	13	5
7	Speed measurement signal ²⁾ (pulse string, 5 V; 90° phase shifted)	gn	14	7
8	Supply voltage zero	bk ³⁾	8	6
	Shield connected to housing ground			

¹⁾ Bridge between 4 + 9



²⁾ RS-422 complementary signals; with cable lengths exceeding 10 m, we recommend using a termination resistor of R = 120 ohms.

³⁾ For KAB163 / KAB164 color code brown (bn)

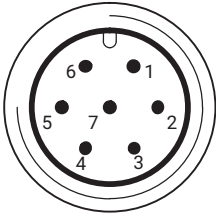
Assignment for plug 3 - supply voltage and voltage output signal



Device plug
Top view

		KAB153	KAB149
Plug pin	Assignment	Color code	D-SUB Plug pin
1	Torque/rotational speed measurement signal (voltage output; 0 V) or rotational speed measurement signal (0 V) 	wh	13
2	Supply voltage 0 V 	bk	5
3	Supply voltage 18 V to 30 V DC	bu	6
4	Torque measurement signal (voltage output; ± 10 V) or rotational speed measurement signal (± 10 V)	rd	12
5	Not in use	gy	8
6	Shunt signal resolution 5 V to 30 V and TEDS for torque	gn	14
7	Shunt signal 0 V 	gy	8
	Shield connected to housing ground		



Important

If power supplied to the device via plug 3, high frequencies must be filtered out. For applications in the USA, the use of an EMI filter/toroidal strip-wound core on the mains cable is mandatory, to ensure compliance with FCC Rules. The same applies to applications in the EU, for compliance with the relevant EMC requirements.

Notice

Do not use cable KAB149 to connect the voltage output signal at AP01i to ML01B of the MGCplus system!
This cable is only suitable for the frequency output signal connection.



Information

The analog output is designed as a monitoring output. The power transmission of the torque transducer can cause interference on the connected cable of up to 40 mV at 13.56 MHz. This interference can be suppressed by the parallel connection of a 100 nF capacitor, directly at the connected measuring device.

Assignment for plug 4

Standard CAN bus; A-coded, black washer

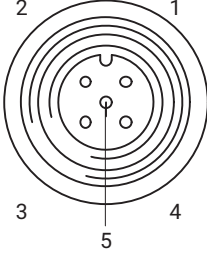
Binder 713 (M12x1)  Top view	Plug pin	Assignment	Color code
	1	Shield	-
	2	Not in use	-
	3	CAN ground	-
	4	CAN HIGH dominant high	wh
	5	CAN LOW dominant low	bu
		Shield connected to housing ground	

Assignment for plug 5

CAN bus, second device plug; A-coded, black washer

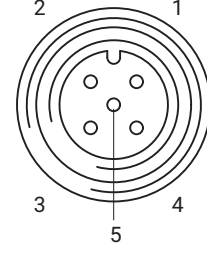
Binder 713 (M12x1)  Top view	Plug pin	Assignment	Color code
	1	Shield	-
	2	Not in use	-
	3	CAN ground	-
	4	CAN HIGH dominant high	wh
	5	CAN LOW dominant low	bu
		Shield connected to housing ground	

Assignment for plug 5

PROFIBUS (option); B-coded, violet washer

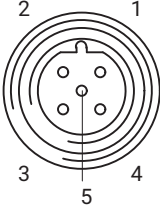
 <p>Binder 715 (M12x1)</p> <p>Top view</p>	Plug pin	Assignment	Color code
	1	5 V (typ. 50 mA)	-
	2	PROFIBUS A	gn
	3	PROFIBUS ground	-
	4	PROFIBUS B	rd
	5	Shield	
		Shield connected to housing ground	

10.4 Supply voltage

The transducer must be operated with a safety extra low voltage (nominal (rated) supply voltage 18 to 30 V_{DC}). You can supply one or more torque flanges within a test bench. Should the device be operated on a DC voltage network¹⁾⁾, additional precautions must be taken to discharge overvoltages.

The information in this section relates to the stand-alone operation of the T12HP without HBK system solutions.

The supply voltage is electrically isolated from the signal outputs and shunt signal inputs.

Connect a safety extra low voltage of 18 V to 30 V to pin 3 (+) and pin 2 (⚡) of plugs 1 or 3. We recommend using HBK cable KAB 8/00-2/2/2 and the relevant Binder sockets, that at nominal (rated) voltage (24 V) can be up to 50 m long, and in the nominal voltage range, 20 m long (see "Accessories", page 102).

If the permissible cable length is exceeded, you can feed the supply voltage in parallel over two connection cables (plugs 1 and 3). This enables you to double the permissible length. Alternatively, install an on-site power supply.

If you feed the supply voltage through an unshielded cable, the cable must be twisted (interference suppression). We also recommend that a ferrite element should be located close to the connector plug on the cable, and that the stator should be grounded.



Important

The instant you switch on, a current of up to 4 A may flow and this can switch off power packs with electronic current limiters.

¹⁾⁾ Distribution system for electrical energy with greater physical expansion (over several test benches, for example) that may possibly also supply consumers with high nominal (rated) currents.

11 SHUNT SIGNAL

The T12HP torque transducer delivers a shunt signal, at either 50% or 10% of the nominal (rated) torque, as selected. Activate this function via the T12HP Assistant or the shunt signal resolution on plug 1 or plug 3 (see *Section 10.3*). The shunt signal most recently selected in the T12HP Assistant is then triggered.



Information

Internal signal conditioning can cause a delay in triggering of about 5 seconds.

To achieve stable conditions, it is advisable to only activate the shunt signal once the transducer has been warming up for 15 minutes.

The boundary conditions for reproducibility (e.g. the mounting conditions) must be established in order to reproduce the measured values in the test report.



Important

The transducer should not be under load when the shunt signal is being measured, as the signal is applied additively.



Information

After about 5 minutes, the shunt signal is automatically deactivated.

12 LOAD-CARRYING CAPACITY

Nominal (rated) torque can be exceeded statically up to the torque limit. If the nominal torque is exceeded, additional irregular loading is not permissible. This includes longitudinal forces, lateral forces and bending moments. The limit values can be found in *Chapter 17, "Specifications", page 71*.

Measuring dynamic torque

The torque transducer is suitable for measuring static and dynamic torques. The following apply to the measurement of dynamic torque:

- The T12HP calibration performed for static measurements is also valid for dynamic torque measurements.
- The natural frequency f_0 of the mechanical measuring arrangement depends on the moments of inertia J_1 and J_2 of the connected rotating masses and the torsional stiffness of the T12HP.

Use the equation below to approximately determine the natural frequency f_0 of the mechanical measurement system:

$$f_0 = \frac{1}{2\pi} \cdot \sqrt{c_T \cdot \left(\frac{1}{J_1} + \frac{1}{J_2} \right)}$$

f_0	=	natural frequency in Hz
J_1, J_2	=	mass moment of inertia in kg·m ²
c_T	=	torsional stiffness in N·m/rad

- The maximum vibration bandwidth is 200% (measurement ranges 3 kN·m to 10 kN·m: 160%) of the typical nominal (rated) torque of the T12HP (see "Specifications", page 71). The oscillation bandwidth must lie between the maximum upper and lower torques of the defined loading range. The same also applies to transient resonance points.

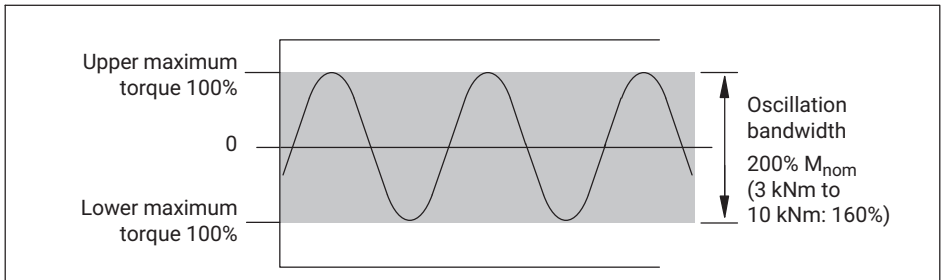

Fig. 12.1 Permissible dynamic loading

TEDS (Transducer Electronic Data Sheet) allows you to store the transducer data (rated outputs) in a chip, that can be read out by a connected measuring device.



Information

Not all available amplifiers/measuring devices support the TEDS functionality of the T12 torque transducer.

The T12HP digital torque transducer has two TEDS modules:

- TEDS 1 (torque): A choice of voltage sensor or frequency sensor/pulse sensor
- TEDS 2 (speed/angle of rotation): Frequency sensor/pulse sensor

The data are written automatically into the TEDS modules by the T12HP Assistant, when the parameters are stored. The same menu is used to select whether the device should be presented as a voltage sensor and as a frequency sensor or as a frequency or pulse sensor. A template is also stored, which provides the conversion factors for the various physical quantities.

The T12HP is a transducer, that is to say, the T12HP does not read the TEDS modules, it only writes them. (We therefore strongly advise against editing the values with the HBK TEDS Editor, for example!)

You can use the TEDS Editor to read the TEDS module data.



Important

To ensure that the data of the TEDS modules correspond to the properties of the T12HP torque transducer, you must not overwrite the information from the amplifier.

For more information on TEDS, look in the T12HP Assistant online Help.

Contents of the TEDS memory as defined in IEEE 1451.4

The information in the TEDS memory is organized into areas, which are prestructured to store defined groups of data in table form.

Only the entered values are stored in the TEDS memory itself. The amplifier firmware assigns the interpretation of the respective numerical values. This places a very low demand on the TEDS memory. The memory content is divided into three areas:

Area 1

An internationally unique TEDS identification number (cannot be changed).

Area 2

The base area (basic TEDS), to the configuration defined in standard IEEE 1451.4. The transducer type, the manufacturer and the transducer serial number are contained here.

Example: TEDS content of a T12HP/1 kN · m transducer

TEDS	
Manufacturer	HBK (31)
Model	T12HP (15)
Version letter	A
Version number	2 first position of stator ID no.
Serial number	7 first position of stator ID no.

Area 3

Data specified by the manufacturer and the user are contained in this area. Typical values for an HBK T12HP/1 kN · m torque transducer are shown in the "Value" column of the tables below.

Torque

HBK has already written the "Frequency/Pulse Sensor" and "High Level Voltage Output Sensor" templates for the measured quantity of torque.

Template: Frequency/Pulse Sensor				
Parameter	Value	Unit	Required user rights	Explanation
Transducer Electrical Signal Type	Pulse Sensor		ID	
Minimum Torque	0.000	N · m	CAL	The physical measurand and unit are defined when the template is created, after which they cannot be changed.
Maximum Torque	1000	N · m	CAL	
Pulse Measurement Type	Frequency			

Template: Frequency/Pulse Sensor				
Parameter	Value	Unit	Required user rights	Explanation
Minimum Electrical Value	10000	Hz	CAL	The difference between these values is the rated output (nominal).
Maximum Electrical Value	15000	Hz	CAL	
Mapping Method	Linear			
Discrete Signal Type	Active High		ID	
Discrete Signal Amplitude	4	V		
Discrete Signal Configuration	Single			
Transducer Response Time	0	sec.		
Excitation Level nom	24	V		
Excitation Level min	18	V		
Excitation Level max	30	V		
Excitation Type	DC			
Excitation Current draw	0.5	A		
Calibration Date	1-Nov-2006	CAL		<p>Date of the last calibration or creation of the test report (if no calibration carried out), or of the storage of the TEDS data (if only nominal (rated) values from the data sheet were used).</p> <p>Format: day-month-year.</p> <p>Abbreviations for the months: Jan, Feb, Mar, Apr, May, Jun, Jul, Aug, Sep, Oct, Nov, Dec.</p>

Template: Frequency/Pulse Sensor				
Parameter	Value	Unit	Required user rights	Explanation
Calibration Initials	HBM or PTB		CAL	Initials of the calibrator or calibration laboratory concerned.
Calibration Period (Days)	0	days	CAL	Time before recalibration, calculated from the date specified under Calibration Date.
Measurement location ID	0		USR	Identification number for the measuring point. Can be assigned according to the application. Possible values: a number from 0 to 2047.

Template: High Level Voltage Sensor				
Parameter	Value	Unit	Required user rights	Explanation
Minimum Torque	0.000	N · m	CAL	The physical measurand and unit are defined when the template is created, after which they cannot be changed.
Maximum Torque	1000	N · m	CAL	
Minimum Electrical Value	0	V	CAL	The difference between these values is the rated output (nominal).
Maximum Electrical Value	10	V	CAL	
Discrete Signal Type	Active High		ID	
Discrete Signal Amplitude	5	V		
Discrete Signal	Single			
Transducer Response Time	0			
Excitation Level nom	24	V		

Template: High Level Voltage Sensor				
Parameter	Value	Unit	Required user rights	Explanation
Excitation Level min	18	V		
Excitation Level max	30	V		
Excitation Type	DC			
Excitation Current draw	0.5	A		
Calibration Date	1-Nov-2006	CAL		Date of the last calibration or creation of the test report (if no calibration carried out), or of the storage of the TEDS data (if only nominal (rated) values from the data sheet were used). Format: day-month-year. Abbreviations for the months: Jan, Feb, Mar, Apr, May, Jun, Jul, Aug, Sep, Oct, Nov, Dec.
Calibration Initials	HBM or PTB		CAL	Initials of the calibrator or calibration laboratory concerned.
Calibration Period (Days)	0	days	CAL	Time before recalibration, calculated from the date specified under Calibration Date.
Measurement Location ID	0		USR	Identification number for the measuring point. Can be assigned according to the application. Possible values: a number from 0 to 2047.

Speed/angle of rotation

HBK has already written the “Frequency/Pulse Sensor” template for the measured quantity of rotational speed.

Template: Frequency/Pulse Sensor				
Parameter	Value	Unit	Required user rights	Explanation
Transducer Electrical Signal Type	Pulse Sensor		ID	
Minimum Frequency	0.000	Hz	CAL	The physical measurand and unit are defined when the template is created, after which they cannot be changed.
Maximum Frequency	108.000k	Hz	CAL	
Pulse Measurement Type	Frequency			
Minimum Electrical Value	0	Hz	CAL	
Maximum Electrical Value	108.000k	Hz	CAL	
Mapping Method	Linear			
Discrete Signal Type	Active High		ID	
Discrete Signal Amplitude	4	V		
Discrete Signal Configuration	Double phase plus zero index			
Transducer Response Time	0	sec.		
Excitation Level nom	24	V		
Excitation Level min	18	V		
Excitation Level max	30	V		

Template: Frequency/Pulse Sensor				
Parameter	Value	Unit	Required user rights	Explanation
Excitation Type	DC			
Excitation Current draw	0.5	A		
Calibration Date	1-Nov-2006	CAL		Date of the last calibration or creation of the test report (if no calibration carried out), or of the storage of the TEDS data (if only nominal (rated) values from the data sheet were used). Format: day-month-year. Abbreviations for the months: Jan, Feb, Mar, Apr, May, Jun, Jul, Aug, Sep, Oct, Nov, Dec.
Calibration Initials	HBM or PTB		CAL	Initials of the calibrator or calibration laboratory concerned.
Calibration Period (Days)	0	days	CAL	Time before recalibration, calculated from the date specified under Calibration Date.
Measurement location ID	0		USR	Identification number for the measuring point. Can be assigned according to the application. Possible values: a number from 0 to 2047.
Transducer Electrical Signal Type	Pulse Sensor		ID	
Minimum Frequency	0.000E+000	degrees	CAL	The physical measurand and unit are defined when the template is created, after which they cannot be changed.
Maximum Frequency	3.6E+002	degrees	CAL	

Template: Frequency/Pulse Sensor				
Parameter	Value	Unit	Required user rights	Explanation
Pulse Measurement Type	Count			
Minimum Electrical Value	0.0	pulses	CAL	The difference between these values is the rated output (nominal).
Maximum Electrical Value	360	pulses	CAL	
Mapping Method	Linear			
Discrete Signal Type	Active High		ID	
Discrete Signal Amplitude	4	V		
Discrete Signal Configuration	Double phase plus zero index			
Transducer Response Time	0	sec.		
Excitation Level nom	24	V		
Excitation Level min	18	V		
Excitation Level max	30	V		
Excitation Type	DC			
Excitation Current draw	0.5	A		

Template: Frequency/Pulse Sensor				
Parameter	Value	Unit	Required user rights	Explanation
Calibration Date	1-Nov-2006	CAL		Date of the last calibration or creation of the test report (if no calibration carried out), or of the storage of the TEDS data (if only nominal (rated) values from the data sheet were used). Format: day-month-year. Abbreviations for the months: Jan, Feb, Mar, Apr, May, Jun, Jul, Aug, Sep, Oct, Nov, Dec.
Calibration Initials	HBM or PTB		CAL	Initials of the calibrator or calibration laboratory concerned.
Calibration Period (Days)	0	days	CAL	Time before recalibration, calculated from the date specified under Calibration Date.
Measurement location ID	0		USR	Identification number for the measuring point. Can be assigned according to the application. Possible values: a number from 0 to 2047.

T12 / T12HP stator firmware version 1.26

! **Important**

The TEDS functionality applies exclusively for QuantumX amplifiers MX460B, MX840B and MX440B

General overview

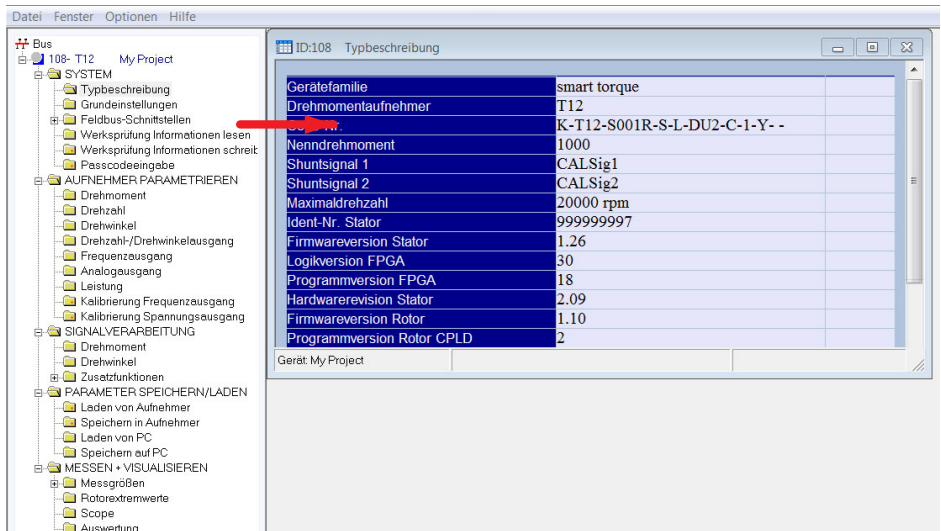

Fig. 14.1

The type description includes all important information about the rotor and stator used. This includes for example:

- Type
- Material number
- Nominal (rated) measuring range
- Nominal (rated) rotational speed
- Serial number of rotor, stator
- Firmware version of rotor, stator
- Hardware version of rotor, stator, etc.

Write T12HP torque calibration information to TEDS, with frequency output as example:

To enter the required data follow these steps:

- ▶ Enter the calibration points (two-point scaling / physical and electrical values) and any additional calibration information (red)
- ▶ Set Write calibration information to "ON" (yellow)
- ▶ Then confirm with OK (green)

Figure 14.2 shows the calibration configuration for TEDS, frequency output. The interface is divided into two main sections: a tree view on the left and a data entry table on the right.

The tree view on the left shows the project structure under '114- T12 My Project'. The 'Kalibrierung Frequenzausgang' folder is selected, indicated by a red arrow.

The data entry table on the right contains the following information:

Parameter	Value	Unit
Kalibrierung aktiv	Aus	
1. Kal.-Punkt physikalischer Istwert	0.000	N·m
1. Kal.-Punkt elektrischer Istwert	10.000000	kHz
2. Kal.-Punkt physikalischer Istwert	512.000	N·m
2. Kal.-Punkt elektrischer Istwert	15.000000	kHz
Kalibrierung Datum (tt.mm.jjjj)	06.09.2017	
Kalibrierung Initialen	abc	
Kalibrierung Zyklus Tage	200	
Ident-Nr. Rotor	121930010	
Ident-Nr. Stator	876543210	
Einstellungen kompatibel	Nein	
Messstellenummer	65535	
Kalibrierung schreiben/überschreiben	Aus	
Kalibrierung löschen/entfernen	Aus	

The 'OK' button is highlighted with a green box, and the 'Kalibrierung schreiben/überschreiben' row is highlighted with a yellow box. A red box highlights the first four rows of the table, which correspond to the calibration points mentioned in the instructions.

Fig. 14.2 Calibration information for TEDS, frequency output

- ▶ Next open the menu again and switch calibration active to "ON" (orange) and then confirm with OK (green)

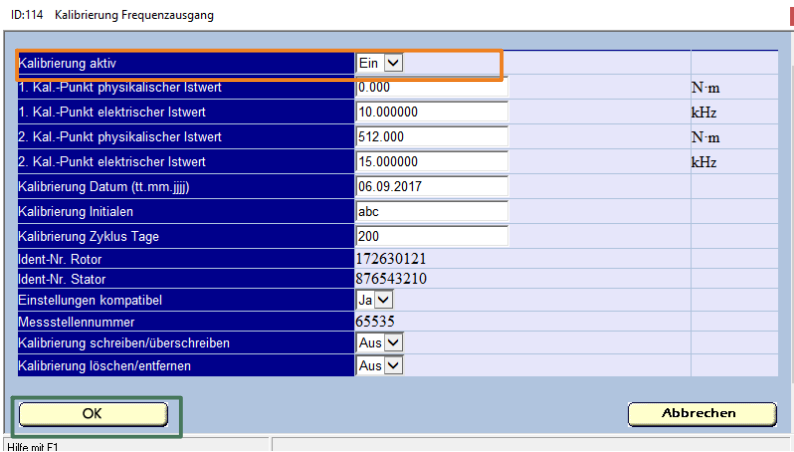
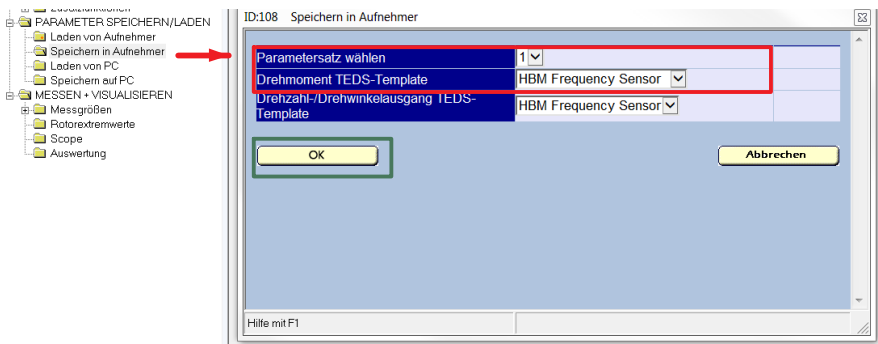

Fig. 14.3 Calibration information for TEDS, frequency output

- ▶ Then save the settings for torque to the TEDS provided for them in the transducer under the parameter set you choose. Next select the desired sensor type and confirm with (green)



Information is only written to TEDS when the parameter set is saved.

- ▶ TEDS data is read automatically after the T12(HP) transducer is connected to the QuantumX module MX460B, MX840B/440B. Then TEDS can be read with the TEDS editor (for example QuantumX Assistant) and the entries can be checked.



Important

Any change to the TEDS information (calibration) must be confirmed with 3) OK and confirmed to save in the parameter set with 5). Otherwise it will not be active.



Important

The TEDS of the T12HP may only be edited / written to with the T12 Assistant! Writing with the TEDS editor, for example, is not permitted. The T12 Assistant is always the TEDS master. If TEDS is written to with the QuantumX TEDS editor despite this, the next time the T12/T12HP restarts or when the parameter sets are loaded, the content will be overwritten by the valid values (parameter set) of the T12 Assistant.



Information

The latest Assistant software for QuantumX and the TEDS editor (DLL) must be used to detect T12HP.

Calibration active ON/OFF is used to control whether the calibration table will be written to TEDS during the TEDS write process (restart or write parameters menu). The downstream QuantumX amplifier series MX460B or MX840B/440B is then able to use the calibration data saved in TEDS for compensation. Normally information is always written to the measuring point.

The calibration points are the two points that are entered while calibrating on the calibration machine. They indicate the calibration protocol. For calibration to DIN51309 or VDI2646 we recommend using the rated output derived from the specified interpolation equation(s).

Settings compatible

The "Compatible" entry is read only and cannot be changed. It indicates that calibration can be activated (ON) because important parameters have not been changed (scaling, frequency range, rotor and stator ID, unit)

To overwrite/change values, the Write/overwrite calibration field must be set to ON (which serves as protection against accidental overwriting) – otherwise the changes will not be applied. This does not apply to the Calibration active ON/OFF item.

Writing / overwriting a calibration

The date, calibrator's initials and cycle are linked with this information and form a unit.

Also the rotor and stator ID and the unit of measure.

When rotors and stators with a different ID are used, for example when a rotor or stator is replaced, calibration is automatically deactivated (set to OFF) and therefore switched to invalid. Then the rated output (nominal) is automatically used for scaling



Important

For a deactivated calibration in TEDS to be represented as current, the stator must be restarted (which is generally done when a rotor is exchanged) or the current status/parameter set must be resaved ("Save to transducer" is linked with write to TEDS). Without a restart or "Save to transducer", modified settings/states are not updated in the Assistant in the TEDS data. This applies to all settings.



Important

When a rotor and stator are replaced and the ID is different, the calibration setting is automatically deactivated!

The same thing happens if the output signal scaling of the frequency output is changed in the T12(HP). The calibration setting can and must only be used in the status of scaling that was set during the calibration of the transducer (normally the factory setting).



Information

If the Calibration active OFF setting is not saved with "Save to transducer" and the original rotor is reinstalled, the calibration table (after restarting T12HP with OFF / ON) automatically becomes active again

Deleting/ removing a calibration

Calibrations of frequency / voltage are saved in the respective parameter sets. 4 pairs are possible with 4 parameter sets. To remove these from a parameter set, "Delete/remove calibration" must be set to ON and confirmed with OK. Then save the parameter set (this is necessary to delete the calibration from memory!). Otherwise the original calibration will not be active again after a restart.

The unit in the calibration window is determined at the time when the calibration values are saved by the unit that is currently valid. It remains in effect if the unit changes, but the calibration becomes inactive.

Copying and saving calibrations

A calibration can be copied from one parameter set to another with "Save to parameter set" ...

Checking / reading calibration information

If a calibration is present (active or inactive) it will be displayed as readable in the system menu under "Read calibration of frequency output" no later than after the T12 Assistant is restarted. This makes it very easy to check at a glance whether or not a calibration is present.

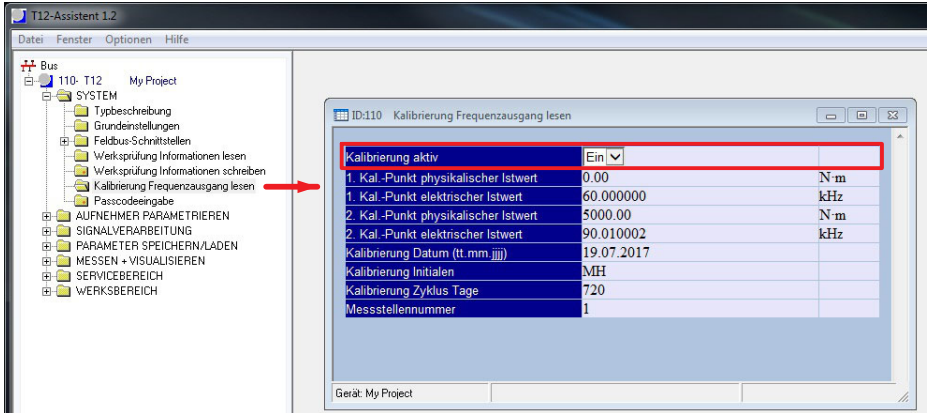

Information

The display can only be read if a calibration is active (i.e. switched to "ON")



Information

The T12 Assistant does not show the updated menu settings under XP until after the T12HP is restarted (switch OFF/ON)

Factory settings

If the factory settings are loaded, the calibration of the current parameter set becomes inactive. It will also be deleted if it has not been saved to a parameter set before the transducer is turned off!

The factory settings can be found under Save / Load.

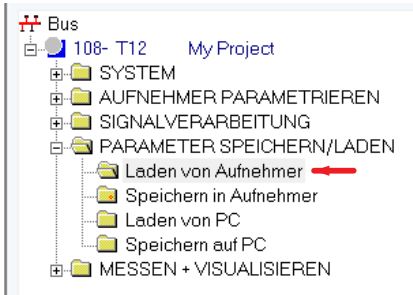

The factory settings apply system-wide. They are not linked with the parameter set.

The information for calibrations and factory settings are distinct and coexist together.

If there is a calibration for an output and it is active, it will overwrite the values of the factory settings in the TEDS descriptions: calibrator's initials, cycle, date.

Essentially the latest/most recent entry applies.

Writing T12HP calibration information of the voltage output to TEDS

The same procedure is used as in the example with the frequency output.

Writing T12HP calibration information for rotational speed/angle of rotation to TEDS

Adjust the desired behavior for the rotational speed output.

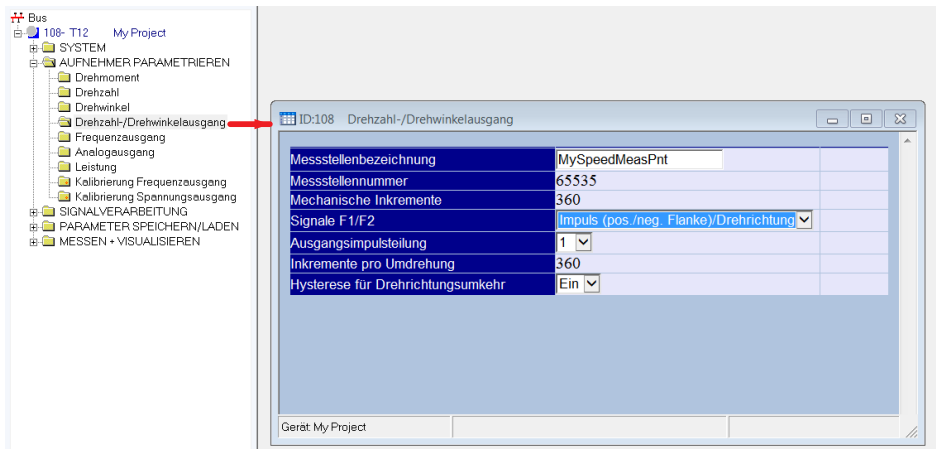

Under signal editing, only the measuring range as shown in figure ... (red) can be used in combination with TEDS functionality for TEDS angle of rotation. This means that the angle of rotation can only be measured with TEDS with the following setting.

No other settings will work.

- Measuring range: 1 x 360 degrees, positive direction of rotation (TEDS N=1)
- Number of revolutions n = 1

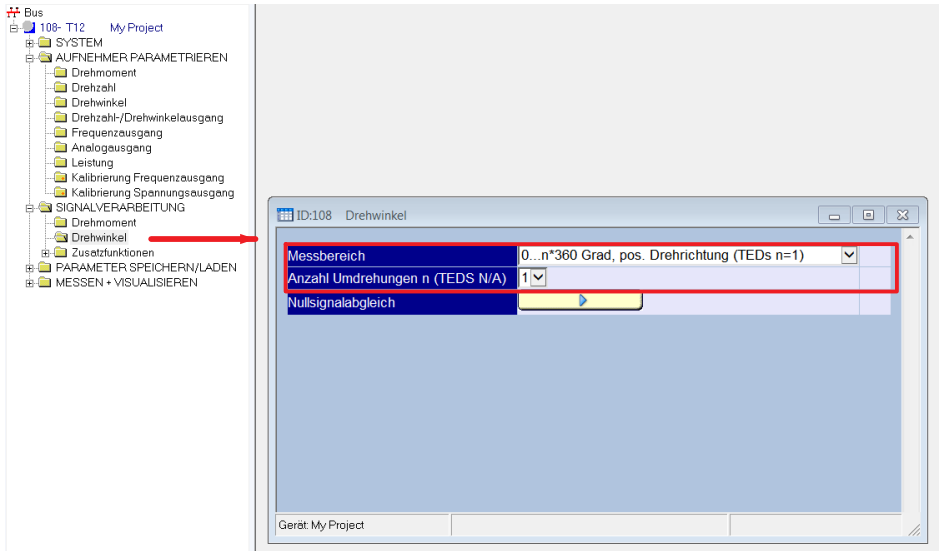

Important

The IEEE template specification does not permit the full scope of the function at this point. This means that any setting other than the one described above will not work with TEDS!

Of course the functions can still be used via the digital interfaces of the T12 stator.

Functionality restricted for TEDS is identified by N/A (Not Available).

Next save the settings for rotational speed/angle of rotation to the TEDS provided for them in the transducer under the parameter set you choose. Then select the desired sensor type.

Bus
108- T12 My Project
SYSTEM
AUFNEHMER PARAMETRIEREN
Drehmoment
Drehzahl
Drehwinkel
Drehzahl-/Drehwinkel Ausgang
Frequenz Ausgang
Analog Ausgang
Leistung
Kalibrierung Frequenz Ausgang
Kalibrierung Spannungs Ausgang
SIGNALVERARBEITUNG
PARAMETER SPEICHERN/LADEN
Laden von Aufnehmer
Speichern in Aufnehmer
Laden von PC
Speichern auf PC
MESSEN + VISUALISIEREN

ID:108 Speichern in Aufnehmer

Parametersatz wählen	1
Drehmoment TEDS-Template	HBM Frequency Sensor
Drehzahl-/Drehwinkel Ausgang TEDS-Template	HBM Pulse Sensor

OK Abbrechen

Hilfe mit F1

The T12HP torque transducer without a rotational speed measuring system is maintenance-free.

Cleaning the rotational speed measuring system

During operation and depending on the ambient conditions, the slotted disc of the rotor and the associated optical system of the stator sensor can get dirty. This becomes noticeable:

- in transducers with a reference pulse, when an incremental error is displayed in the "rotational speed signal" status in the T12HP Assistant
- in transducers without a reference pulse, when there are cyclic intrusions into the rotational speed signal.

Remedy:

1. Use compressed air (up to 6 bar) to clean the slotted disc.
2. Carefully clean the optical system of the sensor with a dry cotton bud or one soaked with pure spirit.

Notice

Do not use any other solvent to clean the optical system of the sensor! It could change the optical properties (by making the plastic cloudy).

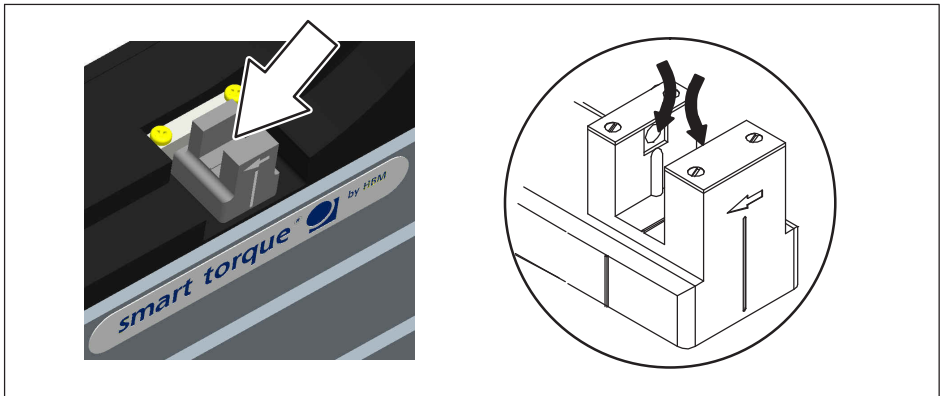

Fig. 15.1 Cleaning points on the rotational speed sensor

16 WASTE DISPOSAL, ENVIRONMENTAL PROTECTION

All electrical and electronic products must be disposed of as hazardous waste. The correct disposal of old equipment prevents ecological damage and health hazards.

Statutory waste disposal mark



The electrical and electronic devices that bear this symbol are subject to the European waste electrical and electronic equipment directive 2002/96/EC. The symbol indicates that, in accordance with national and local environmental protection and material recovery and recycling regulations, old devices that can no longer be used must be disposed of separately and not with normal household garbage.

As waste disposal regulations may differ from country to country, we ask that you contact your supplier to determine what type of disposal or recycling is legally applicable in your country.

Packaging

The original packaging of HBK devices is made from recyclable material and can be sent for recycling. Store the packaging for at least the duration of the warranty. In the case of complaints, the torque flange must be returned in the original packaging.

For ecological reasons, empty packaging should not be returned to us.

17 SPECIFICATIONS

17.1 Nominal (rated) torque 100 N·m to 1 kN·m

Type	T12HP				
Accuracy class	0.02				
Torque measuring system					
Nominal (rated) torque M_{nom}	N·m	100	200	500	1
	kN·m				
Nominal (rated) rotational speed n_{nom}					
Option 4, code L ¹⁾	rpm	15,000		12,000	
Option 4, code H ¹⁾	rpm	18,000		16,000	
Option 4, code F ^{1) 8) 19)}	rpm	22,000		20,000	
Linearity deviation including hysteresis, related to nominal sensitivity					
Fieldbuses, frequency output 10 kHz/60 kHz					
Standard accuracy option: for a max. torque in the range:					
between 0% of M_{nom} and 20% of M_{nom}	%			<±0.005	
> 20% of M_{nom} and 60% of M_{nom}	%			<±0.010	
> 60% of M_{nom} and 100% of M_{nom}	%			<±0.015	
Higher accuracy option: for a max. torque in the range:					
between 0% of M_{nom} and 20% of M_{nom}	%			± 0.003	
> 20% of M_{nom} and 60% of M_{nom}	%			± 0.005	
> 60% of M_{nom} and 100% of M_{nom}	%			± 0.007	
Rel. standard deviation of repeatability per DIN 1319, related to the variation of the output signal					
Fieldbuses/frequency output	%			± 0.005	
Voltage output	%			± 0.03	
Temperature effect per 10 K in the nominal (rated) temperature range					
on the output signal, related to the actual value of the signal span					
Fieldbuses/frequency output	%			<±0.02	
Voltage output	%			<±0.05	

Type	T12HP			
Nominal (rated) torque M_{nom}	N·m	100	200	500
	kN·m			
on the zero signal, related to the nominal sensitivity				
Fieldbuses/frequency output	%	±0.010 (higher accuracy option 0.005)		
Voltage output	%	±0.04		
Nominal sensitivity (spread between torque = zero and nominal (rated) torque)				
Frequency output 10 kHz/60 kHz	kHz	5/30		
Voltage output	V	10		
Sensitivity tolerance (deviation of the actual output quantity at M_{nom} from the nominal sensitivity)				
Frequency output	%	±0.05		
Voltage output	%	±0.1		
Output signal at torque = zero				
Frequency output 10 kHz/60 kHz	kHz	10/60		
Voltage output	V	0		
Nominal (rated) output signal				
Frequency output				
with positive nominal (rated) torque 10 kHz/60 kHz	kHz	15/90 (5 V symmetrical ²⁾)		
with negative nominal (rated) torque 10 kHz/60 kHz	kHz	5/30 (5 V symmetrical ²⁾)		
Voltage output				
at positive nominal (rated) torque	V	+10		
at negative nominal (rated) torque	V	-10		
Scaling range				
Frequency output/voltage output	%	10 to 1000 (of M_{nom})		
Resolution				
Frequency output 10 kHz/60 kHz	Hz	0.03/0.25		
Voltage output	mV	0.33		
Residual ripple				
Voltage output	mV	3		

Type	T12HP				
Nominal (rated) torque M_{nom}	N·m	100	200	500	
	kN·m				1
Maximum modulation range ³⁾					
Frequency output 10 kHz/60 kHz	kHz	4 to 16/24 to 96			
Voltage output	V	-10.2 to +10.2			
Load resistance					
Frequency output	k Ω	≥ 2			
Voltage output	k Ω	≥ 10			
Long-term drift over 48 h					
Voltage output	mV	± 3			
Measurement frequency range					
Frequency output/voltage output -1 dB	Hz	0 to 4000			
Frequency output/voltage output -3 dB	Hz	0 to 6000			
Low-pass filter LP1	Hz	0.05 to 4000 (fourth-order Bessel, -1 dB); factory setting 1000 Hz			
Low-pass filter LP2	Hz	0.05 to 100 (fourth-order Bessel, -1 dB); factory setting 1 Hz			
Group delay (low pass LP1: 4 kHz)					
Frequency output 10 kHz/60 kHz	μ s	320/250			
Voltage output	μ s	500			
Energy supply					
Nominal (rated) supply voltage (DC) (safety extra-low voltage)	V	18 to 30			
Current consumption in measuring mode	A	< 1 (typ. 0.5)			
Current consumption in startup mode	A	< 4			
Nominal (rated) power consumption	W	< 18			
Maximum cable length	m	50			
Shunt signal		50% of M_{nom} or 10% of M_{nom}			
Tolerance of the shunt signal, related to M_{nom}	%	± 0.05			

Type		T12HP			
Nominal (rated) torque M_{nom}	N·m	100	200	500	
	kN·m				1
Speed/angle of rotation measuring system					
Optical, using infrared light and a metallic slotted disc					
Mechanical increments	number	360			
Positional tolerance of the increments	mm	±0.05			
Tolerance of the slot width	mm	±0.05			
Pulses per revolution (adjustable)	number	360; 180; 90; 60; 45; 30			
Pulse frequency at nominal (rated) rotational speed n_{nom}					
Option 4, code L ⁴⁾	kHz	90	72		
Option 4, code H ⁴⁾	kHz	108	96		
Option 4, code F ⁴⁾	kHz	132	120		
Minimum rotational speed for sufficient pulse stability	rpm	2			
Group delay	µs	< 5 (typ. 2.2)			
Hysteresis of direction of rotation reversal in the case of relative vibrations between rotor and stator					
Torsional vibration of the rotor	degrees	< approx. 2			
Radial vibrations of the stator	mm	< approx. 2			
Permitted degree of contamination , in the optical path of the sensor pickup (lenses, slotted disc)	%	< 50			
Effect of turbulence (slotted disk) on the zero point , related to the nominal (rated) torque					
Option 4, code L ⁴⁾	%	<0.05	<0.03	<0.03	<0.03
Option 4, code H ⁴⁾	%	<0.08	<0.04	<0.03	<0.03
Option 4, code F ⁴⁾	%	<0.12	<0.06	<0.05	<0.05
Output signal for frequency/pulse output	V	5 ⁵⁾ symmetrical; two square-wave signals, approx. 90° out of phase			
Load resistance	kΩ	≥ 2			

Type	T12HP				
Nominal (rated) torque M_{nom}	N·m	100	200	500	
	kN·m				1
Rotational speed					
Fieldbuses					
Resolution	rpm	0.1			
System accuracy (with torsional vibrations of max. 3% of the current rotational speed at 2x rotational frequency)	ppm	150			
Max. rotational speed deviation at nominal (rated) rotational speed (100 Hz filter)	rpm	1.5			
Voltage output					
Measurement range	V	±10			
Resolution	mV	0.33			
Scaling range	%	10 to 1000			
Overload limits	V	±10.2			
Load resistance	kΩ	> 10			
Non-linearity	%	< 0.03			
Nominal (rated) power consumption	W	< 18			
Maximum cable length	m	50			
Temperature effect per 10 K in the nominal (rated) temperature range					
on the output signal, related to the actual value of the signal span	%	<0.03			
on the zero signal	%	<0.03			
Residual ripple	mV	< 3			
Angle of rotation					
Accuracy	degrees	1 (typ. 0.1)			
Resolution	degrees	0.01			
Correction of runtime deviation between torque LP1 and the angle of rotation for filter frequencies	Hz	4,000; 2,000; 1,000; 500; 200; 100			
Measurement range	degrees	0 to 360 (single-turn) to ±1440 (multi-turn)			

Type	T12HP				
Nominal (rated) torque M_{nom}	N·m	100	200	500	
	kN·m				1
Power					
Measurement frequency range	Hz	80 (-1 dB)			
Resolution	W	1			
Full scale value	W	$P_{max} = M_{nom} \cdot n_{nom} \cdot \frac{\pi}{30} \frac{[M_{nom}] \text{ in N}\cdot\text{m}}{[n_{nom}] \text{ in rpm}}$			
Temperature effect per 10 K in the nominal (rated) temperature range on the power signal, related to the full scale value	%	$\pm 0.05 \cdot n/n_{nom}$			
Linearity deviation including hysteresis, related to the full scale value	%	$\pm 0.02 \cdot n/n_{nom}$			
Sensitivity tolerance (deviation of the actual measurement signal span of the power signal related to the full scale value)	%	± 0.05			
Temperature signal of the rotor					
Accuracy	K	1			
Measurement frequency range	Hz	5 (-1 dB)			
Resolution	K	0.1			
Physical unit	-	°C			
Sample rate	meas. values/s	40			

- 1) See page 100.
- 2) RS-422 complementary signals, note termination resistor.
- 3) Output signal range in which there is a repeatable correlation between torque and output signal.
- 4) See page 100.
- 5) RS-422 complementary signals, note termination resistors.

Fieldbuses		
CAN bus		
Protocol	-	CAN 2.0B, CAL/CANopen-compatible
Sample rate	meas. values/s	max. 4800 (PDO)

Hardware bus link		as per ISO 11898				
Baud rate	kBit/s	1,000	500	250	125	100
Maximum line length	m	25	100	250	500	600
Connection	-	5-pin, M12x1, A-coding per CANopen DR-303-1 V1.3, electrically isolated from power supply and measurement ground				
PROFIBUS DP						
Protocol	-	PROFIBUS DP Slave, per DIN 19245-3				
Baud rate	MBaud	max. 12				
PROFIBUS Ident Number	-	096C (hex)				
Input data, max.	bytes	152				
Output data, max.	bytes	40				
Diagnostic data	bytes	18 (2 · 4 byte module diagnosis)				
Connection	-	5-pin, M12x1, B-coding, electrically isolated from power supply and measurement ground				
Update rate ⁶⁾						
Configuration entries ≤ 2						4,800
≤ 4						2,400
≤ 8						1,200
≤ 12						600
≤ 16						300
> 16						150
	meas. values/s					
Limit value switches (on fieldbuses only)						
Number	-	4 for torque, 4 for rotational speed				
Reference level	-	Torque low pass 1 or low pass 2 Rotational speed low pass 1 or low pass 2				
Hysteresis	%	0 to 100				
Adjustment accuracy	digits	1				
Response time (LP1 = 4000 Hz)	ms	typ. 3				
TEDS (Transducer Electronic Data Sheet)						
Number	-	2				

TEDS 1 (torque)	-	A choice of voltage sensor or frequency sensor
TEDS 2 (speed/angle of rotation)	-	Frequency/pulse sensor

6) When CAN PDOs are activated simultaneously, the update rate on the PROFIBUS is reduced.

Type		T12HP			
Nominal (rated) torque M_{nom}	N·m	100	200	500	
	kN·m				1
General information					
EMC					
Emission (EME) (per FCC 47 Part 15, Subpart C)	-				
Emission (EME) (per EN61326-1, Table 3)					
RFI voltage	-			Class A	
RFI power	-			Class A	
RFI field strength	-			Class A	
Immunity to interference (EN61326-1, Table A.1)					
Electromagnetic field (AM)	V/m			10	
Magnetic field	A/m			30	
Electrostatic discharge (ESD)					
Contact discharge	kV			4	
Air discharge	kV			8	
Fast transients (burst)	kV			1	
Impulse voltages (surge)	kV			1	
Conducted interference (AM)	V			3	
Degree of protection per EN 60529				IP 54	
Reference temperature	°C			23	
Nominal temperature range	°C			+10 to +70	
Operating temperature range	°C			-10 to +70	
Storage temperature range	°C			-20 to +75	
Mechanical shock and impact testing per DIN IEC 68; Part 2-27; IEC 68-2-27-1987					

Type		T12HP			
Nominal (rated) torque M_{nom}	N·m	100	200	500	
	kN·m				1
Number	n	1000			
Duration	ms	3			
Acceleration (half sine)	m/s ²	650			
Vibration testing per EN 60068-2-6: IEC 68-2-6-1982					
Frequency range	Hz	5 to 2,000			
Duration	h	2.5			
Acceleration (amplitude)	m/s ²	100			
Load limits 7)					
Limit torque, (static) ±	% of	200			
Breaking torque, (static) ±	M_{nom}	> 400			
Axial limit force (static) ±	kN	5	10	16	19
Axial limit force (dynamic) amplitude	kN	2.5	5	8	8.5
Lateral limit force (static) ±	kN	1	2	4	5
Lateral limit force (dynamic) amplitude	kN	0.5	1	2	2.5
Bending limit moment (static) ±	N·m	50	100	200	220
Bending limit moment (dynamic) amplitude	N·m	25	50	100	110
Oscillation width per DIN 50100 (peak-to-peak) 9)	N·m	200	400	1,000	2,000
Mechanical values					
Torsional stiffness c_T	kN·m/ rad	230	270	540	900
Torsion angle at M_{nom}	degrees	0.048	0.043	0.055	0.066
Stiffness in the axial direction c_a	kN/mm	420	800	740	760
Stiffness in the radial direction c_r	kN/mm	130	290	550	810
Stiffness during the bending moment round a radial axis c_b	kN·m/ degrees	3.8	7	11.5	12
Maximum deflection at axial limit force	mm	<0.02		<0.03	
Additional max. radial deviation at lateral limit force	mm	<0.02			

Type		T12HP			
Nominal (rated) torque M_{nom}	N·m	100	200	500	
	kN·m				1
Additional deviation from plane parallelism at bending limit moment (at $\varnothing d_B$)	mm	<0.03		<0.05	
Balance quality level per DIN ISO 1940		G 2.5			
Max. limits for relative shaft vibration (peak-to-peak)¹⁰⁾ Undulations in the connection flange area, based on ISO 7919-3	μm	Normal operation (continuous operation) $s_{(p-p)} = \frac{9000}{\sqrt{n}}$ Start and stop operation, resonance ranges (temporary) $s_{(p-p)} = \frac{13200}{\sqrt{n}}$ (n in rpm)			
Mass moment of inertia of the rotor I_V (around rotary axis) I_V with optical rotational speed measuring system	kg·m ² kg·m ²	0.0023 0.0025	0.0033 0.0035	0.0059 0.0062	
Proportional mass moment of inertia for the transmitter side without rotational speed measuring system with optical rotational speed measuring system	% %	58 56		56 54	
Max. permissible static eccentricity of the rotor (radially) to the center point of the stator without rotational speed measuring system with rotational speed measuring system	mm mm	± 2 ± 1			
Max. permissible axial displacement of the rotor to the stator	mm	± 2			
Weight, approx. Rotor Stator	kg kg	1.1	1.8	2.4 2.3	

- 7) Each type of irregular stress (bending moment, lateral or axial force, exceeding nominal (rated) torque) can only be permitted up to its specified limit, provided none of the others can occur at the same time. If this condition is not met, the limit values must be reduced. If 30% of the bending limit moment and lateral limit force occur at the same time, only 40% of the axial limit force is permissible and the nominal (rated) torque must not be exceeded. The effects of 10% of the permissible bending moments, axial and lateral forces on the measurement result are $\pm 0.02\%$ (Code S,U); $\pm 0.01\%$ (Code W) of the nominal (rated) torque.
- 8) Limit loads / Option 4, Code F (high-speed version): Limit loads (bending moment, lateral or axial force and oscillation width (peak-to-peak)) are reduced by 20%.
- 9) The nominal (rated) torque must not be exceeded.
- 10) The influence of radial run-out deviations, eccentricity, defects of form, notches, marks, local residual magnetism, structural inhomogeneity or material anomalies needs to be taken into account and isolated from the actual undulation.

17.2 Nominal (rated) torque 2 kN·m to 10 kN·m

Type		T12HP			
Accuracy class		0.02			
Torque measuring system					
Nominal (rated) torque M_{nom}	kN·m	2	3	5	10
Nominal (rated) rotational speed n_{nom}					
Option 3, code L ¹¹⁾		rpm	12,000	10,000	
Option 3, code H ¹¹⁾		rpm	16,000	14,000	12,000
Option 3, code F ^{1) 9) 19)}		rpm	18,000	n.a.	
Linearity deviation including hysteresis , related to nominal sensitivity					
Fieldbuses, frequency output 10 kHz/60 kHz					
For a max. torque in the range:					
between 0% of M_{nom} and 20% of M_{nom}		%	< ± 0.005 (optional < ± 0.003)		
> 20% of M_{nom} and 60% of M_{nom}		%	< ± 0.010 (optional < ± 0.005)		
> 60% of M_{nom} and 100% of M_{nom}		%	< ± 0.015 (optional < ± 0.007)		
Voltage output					
For a max. torque in the range:					
between 0% of M_{nom} and 20% of M_{nom}		%	< ± 0.015		
> 20% of M_{nom} and 60% of M_{nom}		%	< ± 0.035		
> 60% of M_{nom} and 100% of M_{nom}		%	< ± 0.05		
Rel. standard deviation of repeatability per DIN 1319, related to the variation of the output signal					
Fieldbuses/frequency output		%	± 0.005		
Voltage output		%	± 0.03		
Temperature effect per 10 K in the nominal (rated) temperature range					

Type		T12HP			
Nominal (rated) torque M_{nom}	kN·m	2	3	5	10
on the output signal, related to the actual value of the signal span					
Fieldbuses/frequency output	%	±0.02			
Voltage output	%	±0.5			
on the zero signal, related to the nominal sensitivity					
Fieldbuses/frequency output	%	±0.01 (optional ±0.005)			
Voltage output	%	±0.04			
Nominal sensitivity (spread between torque = zero and nominal (rated) torque)					
Frequency output 10 kHz/60 kHz	kHz	5/30			
Voltage output	V	10			
Sensitivity tolerance (deviation of the actual output quantity at M_{nom} from the nominal sensitivity)					
Frequency output	%	±0.05			
Voltage output	%	±0.1			
Output signal at torque = zero					
Frequency output 10 kHz/60 kHz	kHz	10/60			
Voltage output	V	0			
Nominal (rated) output signal					
Frequency output					
with positive nominal (rated) torque 10 kHz/60 kHz	kHz	15/90 (5 V symmetrical ¹²⁾)			
with negative nominal (rated) torque 10 kHz/60 kHz	kHz	5/30 (5 V symmetrical ¹²⁾)			
Voltage output					
at positive nominal (rated) torque	V	+10			
at negative nominal (rated) torque	V	-10			
Scaling range					
Frequency output/voltage output	%	10 to 1000 (of M_{nom})			
Resolution					
Frequency output 10 kHz/60 kHz	Hz	0.03/0.25			
Voltage output	mV	0.33			
Residual ripple					
Voltage output	mV	3			

Type		T12HP			
Nominal (rated) torque M_{nom}	kN·m	2	3	5	10
Maximum modulation range ¹³⁾					
Frequency output 10 kHz/60 kHz	kHz	4 to 16/24 0 96			
Voltage output	V	-10.2 to +10.2			
Load resistance					
Frequency output	kΩ	≥2			
Voltage output	kΩ	≥10			
Long-term drift over 48 h					
Voltage output	mV	±3			
Measurement frequency range					
Frequency output/voltage output -1 dB	Hz	0 to 4000			
Frequency output/voltage output -3 dB	Hz	0 to 6000			
Low-pass filter LP1		0.05 to 4000 (fourth order Bessel, -1 dB); factory setting 1000 Hz			
Low-pass filter LP2		0.05 to 100 (fourth order Bessel, -1 dB); factory setting 1 Hz			
Group delay (low pass LP1: 4 kHz)					
Frequency output 10 kHz/60 kHz	μs	320/250			
Voltage output	μs	500			
Energy supply					
Nominal (rated) supply voltage (DC) (safety extra low voltage)	V	18 to 30			
Current consumption in measuring mode	A	< 1 (typ. 0.5)			
Current consumption in startup mode	A	< 4			
Nominal (rated) power consumption	W	<18			
Maximum cable length	m	50			
Shunt signal		50% of M_{nom} or 10% of M_{nom}			
Tolerance of the shunt signal, related to M_{nom}		%			
		±0.05			
Speed/angle of rotation measuring system					
Optical, using infrared light and a metallic slotted disc					
Mechanical increments		number	360	720	
Positional tolerance of the increments		mm	±0.05		
Tolerance of the slot width		mm	±0.05		

Type		T12HP			
Nominal (rated) torque M_{nom}	kN·m	2	3	5	10
Pulses per revolution (adjustable)	number	360; 180; 90; 60; 45; 30		720; 360; 180; 120; 90; 60	
Pulse frequency at nominal (rated) rotational speed n_{nom}					
Option 4, code L ¹¹⁾	kHz	72		120	
Option 4, code H ¹¹⁾	kHz	96		168	
Option 4, code F ¹¹⁾	kHz	108		not available	
Minimum rotational speed for sufficient pulse stability	rpm	2			
Group delay	µs	< 5 (typ. 2.2)			
Hysteresis of direction of rotation reversal in the case of relative vibrations between rotor and stator					
Torsional vibration of the rotor	degrees	< approx. 2			
Radial vibrations of the stator	mm	< approx. 2			
Permitted degree of contamination, in the optical path of the sensor pickup (lenses, slotted disc)	%	< 50			
Effect of turbulence (slotted disk) on the zero point, related to the nominal (rated) torque					
Option 4, code L ¹¹⁾	%	<0.02		<0.01	
Option 4, code H ¹¹⁾	%	<0.02		<0.01	
Option 4, code F ¹¹⁾	%	<0.03		not available	
Output signal for frequency/pulse output	V	5 ¹⁴⁾ symmetrical; two square-wave signals, approx. 90° out of phase			
Load resistance	kΩ	≥ 2			
Rotational speed					
Fieldbuses					
Resolution	rpm	0.1			
System accuracy (with torsional vibrations of max. 3% of the current rotational speed at 2x rotational frequency)	ppm	150			

Type		T12HP			
Nominal (rated) torque M_{nom}	kN·m	2	3	5	10
Max. rotational speed deviation at nominal (rated) rotational speed (100 Hz filter)	rpm	1.5			
Voltage output					
Measurement range	V	±10			
Resolution	mV	0.33			
Scaling range	%	10 to 1000			
Overload limits	V	±10.2			
Load resistance	kΩ	> 10			
Non-linearity	%	< 0.03			
Nominal (rated) power consumption	W	< 18			
Maximum cable length	m	50			
Temperature effect per 10 K in the nominal (rated) temperature range					
on the output signal, related to the actual value of the signal span	%	< 0.03			
on the zero signal	%	< 0.03			
Residual ripple	mV	< 3			
Angle of rotation					
Accuracy	degrees	1 (typ. 0.1)			
Resolution	degrees	0.01			
Correction of runtime deviation between torque LP1 and the angle of rotation for filter frequencies	Hz	4000; 2000; 1000; 500; 200; 100			
Measurement range	degrees	0 to 360 (single-turn) to ±1440 (multi-turn)			
Power					
Measurement frequency range	Hz	80 (-1 dB)			
Resolution	W	1			
Full scale value	W	$P_{max} = M_{nom} \cdot n_{nom} \cdot \frac{\pi}{30} \frac{[M_{nom}] \text{ in}}{[n_{nom}] \text{ in rpm}}$			

Type		T12HP			
Nominal (rated) torque M_{nom}	kN·m	2	3	5	10
Temperature effect per 10 K in the nominal (rated) temperature range on the power signal , related to the full scale value	%	$\pm 0.05 \cdot n/n_{nom}$			
Linearity deviation including hysteresis , related to the full scale value	%	$\pm 0.02 \cdot n/n_{nom}$			
Sensitivity tolerance (deviation of the actual measurement signal span of the power signal related to the full scale value)	%	± 0.05			
Temperature signal of the rotor					
Accuracy	K	1			
Measurement frequency range	Hz	5 (-1 dB)			
Resolution	K	0.1			
Physical unit	-	°C			
Sample rate	meas. values/s	40			

1¹⁾ See page 100.

1²⁾ RS-422 complementary signals, note termination resistor.

1³⁾ Output signal range in which there is a repeatable correlation between torque and output signal.

1⁴⁾ RS-422 complementary signals, note termination resistors.

Fieldbuses						
CAN bus						
Protocol	-	CAN 2.0B, CAL/CANopen-compatible				
Sample rate	meas. values/s	max. 4800 (PDO)				
Hardware bus link		as per ISO 11898				
Baud rate	kBit/s	1000	500	250	125	100
Maximum line length	m	25	100	250	500	600
Connection	-	5-pin, M12x1, A-coding per CANopen DR-303-1 V1.3, electrically isolated from power supply and measurement ground				
PROFIBUS DP						
Protocol	-	PROFIBUS DP Slave, per DIN 19245-3				
Baud rate	MBaud	max. 12				
PROFIBUS Ident Number	-	096C (hex)				
Input data, max.	bytes	152				
Output data, max.	bytes	40				
Diagnostic data	bytes	18 (2 · 4 byte module diagnosis)				
Connection	-	5-pin, M12x1, B-coding, electrically isolated from power supply and measurement ground				
Update rate ¹⁵⁾						
Configuration entries						
≤ 2	meas. values/s	4800				
≤ 4		2400				
≤ 8		1200				
≤ 12		600				
≤ 16		300				
>16		150				
Limit value switches (on fieldbuses only)						
Number	-	4 for torque, 4 for rotational speed				
Reference level	-	Torque low pass 1 or low pass 2 Rotational speed low pass 1 or low pass 2				
Hysteresis	%	0 to 100				

Adjustment accuracy	digits	1
Response time (LP1 = 4000 Hz)	ms	typ. 3
TEDS (Transducer Electronic Data Sheet)		
Number	-	2
TEDS 1 (torque)	-	A choice of voltage sensor or frequency sensor
TEDS 2 (speed/angle of rotation)	-	Frequency/pulse sensor

¹⁵⁾When CAN PDOs are activated simultaneously, the update rate on the PROFIBUS is reduced.

Nominal (rated) torque M_{nom}	kN·m	2	3	5	10
General information					
EMC					
Emission (EME) (per FCC 47 Part 15, Subsection C ¹⁶⁾)					
Emission (EME) (per EN61326-1, Table 3) ¹⁷⁾					
RFI voltage	-			Class A	
RFI power	-			Class A	
RFI field strength	-			Class A	
Immunity from interference (EN61326-1, Table A.1)					
Electromagnetic field (AM)	V/m			10	
Magnetic field	A/m			30	
Electrostatic discharge (ESD)					
Contact discharge	kV			4	
Air discharge	kV			8	
Fast transients (burst)	kV			1	
Impulse voltages (surge)	kV			1	
Conducted interference (AM)	V			3	
Degree of protection per EN 60529				IP 54	
Reference temperature	°C			23	
Nominal temperature range	°C			+10 to +70	
Operating temperature range	°C			-10 to +70	

Nominal (rated) torque M_{nom}	kN·m	2	3	5	10
Storage temperature range	°C	-20 to +75			
Mechanical shock and impact testing per DIN IEC 68; Part 2-27; IEC 68-2-27-1987					
Number	n	1000			
Duration	ms	3			
Acceleration (half sine)	m/s ²	650			
Vibration testing per EN 60068-2-6: IEC 68-2-6-1982					
Frequency range	Hz	5 to 2,000			
Duration	h	2.5			
Acceleration (amplitude)	m/s ²	100			50
Load limits ¹⁸⁾					
Limit torque, (static) ±	%	200	160		
Breaking torque, (static) ±	of M_{nom}	> 400	> 320		
Axial limit force (static) ±	kN	39	42	80	120
Axial limit force (dynamic) amplitude	kN	19.5	21	40	60
Lateral limit force (static) ±	kN	9	10	12	18
Lateral limit force (dynamic) amplitude	kN	4.5	5	6	9
Bending limit moment (static) ±	N·m	560	600	800	1200
Bending limit moment (dynamic) amplitude	N·m	280	300	400	600
Oscillation width per DIN 50100 (peak-to-peak) ²⁰⁾	N·m	4000	4800	8000	16000
Mechanical values					
Torsional stiffness c_T	kN·m/rad	2300	2600	4600	7900
Torsion angle at M_{nom}	degrees	0.049	0.066	0.06	0.07
Stiffness in the axial direction c_a	kN/mm	950	1000	950	1600
Stiffness in the radial direction c_r	kN/mm	1300	1500	1650	2450
Stiffness during the bending moment round a radial axis c_b	kN·m/degrees	21.7	22.4	43	74
Maximum deflection at axial limit force	mm	<0.05		<0.1	
Additional max. radial deviation at lateral limit force	mm	<0.02			

Nominal (rated) torque M_{nom}	kN·m	2	3	5	10
Additional deviation from plane parallelism at bending limit moment (at $\varnothing d_B$)	mm	<0.07			
Balance quality level per DIN ISO 1940		G 2.5			
Max. limits for relative shaft vibration (peak-to-peak) ²¹⁾ Undulations in the connection flange area, based on ISO 7919-3	μm	Normal operation (continuous operation) $s_{(p-p)} = \frac{9000}{\sqrt{n}}$ Start and stop operation, resonance ranges (temporary) $s_{(p-p)} = \frac{13200}{\sqrt{n}}$ (n in rpm)			
Mass moment of inertia of the rotor I_V (around rotary axis) I_V with optical rotational speed measuring system	kg·m ² kg·m ²	0.0192 0.0196	0.037 0.038	0.097 0.0995	
Proportional mass moment of inertia for the transmitter side without rotational speed measuring system with optical rotational speed measuring system	% %	54 53		53 52	
Max. permissible static eccentricity of the rotor (radially) to the center point of the stator without rotational speed measuring system with rotational speed measuring system	mm mm		± 2 ± 1		
Max. permissible axial displacement of the rotor to the stator	mm		± 2		

Nominal (rated) torque M_{nom}	kN·m	2	3	5	10
Weight, approx.					
Rotor	kg	4.9	8.3	14.6	
Stator	kg	2.4	2.5	2.6	

¹⁶⁾ Option 9, code U

¹⁷⁾ Option 9, code N

¹⁸⁾ Each type of irregular stress (bending moment, lateral or axial force, exceeding nominal (rated) torque) can only be permitted up to its specified limit, provided none of the others can occur at the same time. If this condition is not met, the limit values must be reduced. If 30% of the bending limit moment and lateral limit force occur at the same time, only 40% of the axial limit force is permissible and the nominal (rated) torque must not be exceeded. The effects of 10% of the permissible bending moments, axial and lateral forces on the measurement result are $\pm 0.02\%$ (Code S,U); $\pm 0.01\%$ (Code W) of the nominal (rated) torque.

¹⁹⁾ Limit loads / Option 4, Code F (high-speed version): Limit loads (bending moment, lateral or axial force and oscillation width (peak-to-peak)) are reduced by 20%.

²⁰⁾ The nominal (rated) torque must not be exceeded.

²¹⁾ The influence of radial run-out deviations, eccentricity, defects of form, notches, marks, local residual magnetism, structural inhomogeneity or material anomalies needs to be taken into account and isolated from the actual undulation.

18 DIMENSIONS

Detailed technical drawings are available in the relevant product group on our website at www.hbm.com.

Mounting dimensions

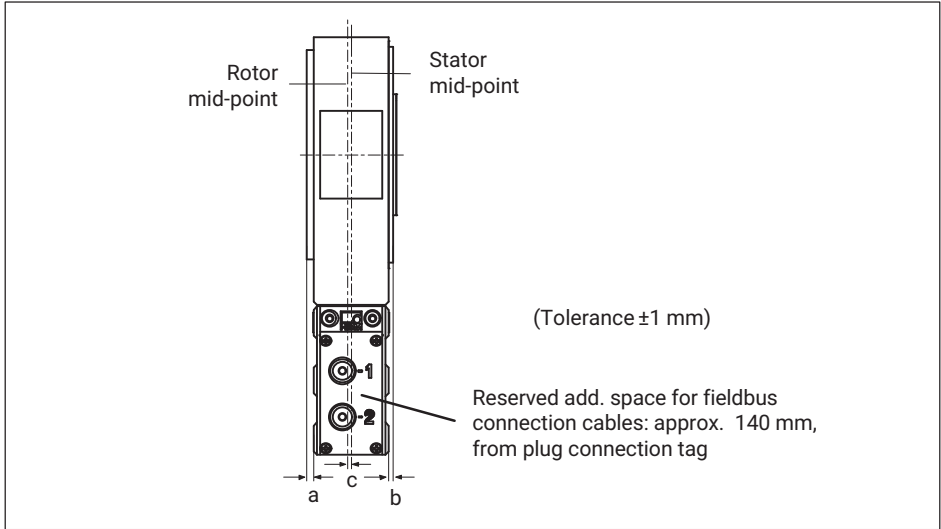

Measurement range	Mounting dimension (mm)		
	a	b	c
100 N·m 200 N·m	4	0	2
500 N·m 1 kN·m	2	2	0
2 kN·m 3 kN·m	5	3	1
5 kN·m	25	3	11
10 kN·m	33	3	15

19 SUPPLEMENTARY TECHNICAL INFORMATION

Axial and radial run-out tolerances

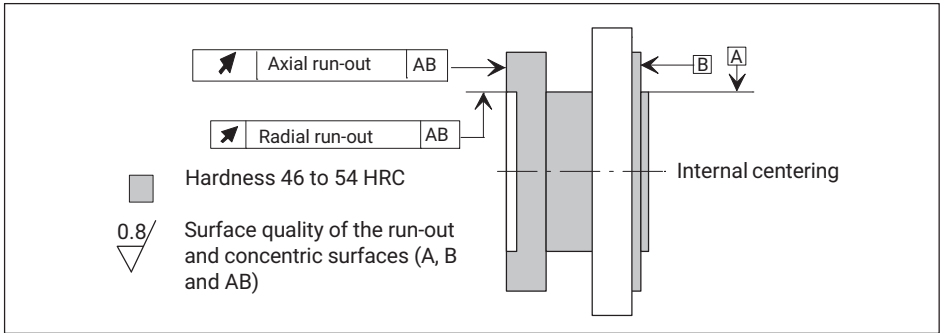

Measurement range (N·m)	Axial run-out tolerance (mm)	Radial run-out tolerance (mm)
100	0.01	0.01
200	0.01	0.01
500	0.01	0.01
1 k	0.01	0.01
2 k	0.02	0.02
3 k	0.02	0.02
5 k	0.025	0.025
10 k	0.025	0.025

20 CONDITION AT THE TIME OF DELIVERY

The parameter factory settings are marked by an asterisk (*). Underlined parameters will not be overwritten by resetting to the factory settings.

SYSTEM	
Default settings	
Project name	My Project
Language	Deutsch; English
Define passcode (1 – 9999)	0
Passcode active?	Yes*; No
Reactivate passcode	Reactivate passcode
LED display mode	Standard (measuring mode) Rotor clearance setting mode Opt. rot. speed measuring system setting mode
Fieldbus interfaces	
CANopen	
CAN address	110
CAN baud rate	100 kB; 125 kB; 250 kB; 500 kB; <u>1000 kB*</u>
LSS manufacturer number	285
LSS product number	1025
LSS revision number	4294967040
LSS serial number	4294967040
PDO output rate divider	1; 2*; 4; 8; 16; 32; 64
Signal PDO 1 (transmit, max. 4.8 kHz)	Off Torque low pass 1* Torque + torque low pass 1 Torque low pass 1 + angle of rotation
Signal PDO 2 (transmit, max. 1.2 kHz)	Off Torque low pass 2* Torque + torque low pass 2
Signal PDO 3 (transmit, max. 0.6 kHz)	Off* Power + rotor temperature

Signal PDO 4 (transmit, max. 0.6 kHz)	Off* Torque, speed/angle of rotation status
Write calibration information	
Torque calibration date (dd.mm.yyyy)	30.11.06
Torque calibration initials	RH
Torque calibration cycle	0
Measuring point number	0
Speed/angle of rotation output calibration date (dd.mm.yyyy)	30.11.06
Speed/angle of rotation output calibration initials	KM
Speed/angle of rotation output calibration cycle	0
Measuring point number	0
Voltage calibration date (dd.mm.yyyy)	30.11.06
Voltage calibration initials	HM
Voltage calibration cycle	0
Measuring point number	0
Passcode entry	
Enter passcode (1 – 9999)	0
TRANSDUCER PARAMETERIZATION	
Torque	
Measuring point name	<u>MyTorqueMeasPnt</u>
Measuring point number	<u>0</u>
Unit	Nm*; kNm; ozfin; ozfft; lbfm; lbfft
Decimal point	.; .0; .00; .000*; .0000; .00000
Sign	Positive*; negative
Low-pass filter 1 (nominal value)	0.05 Hz; 0.1 Hz; 0.2 Hz; 0.5 Hz; 1 Hz; 2 Hz; 5 Hz; 10 Hz; 20 Hz; 50 Hz; 100 Hz; 200 Hz; 500 Hz; 1 kHz*; 2 kHz; 4 kHz
Low-pass filter 2 (nominal value)	0.05 Hz; 0.1 Hz; 0.2 Hz; 0.5 Hz; 1 Hz*; 2 Hz; 5 Hz; 10 Hz; 20 Hz; 50 Hz; 100 Hz

Measure 1st point	Measure 1st point
1st point physical actual value	0.000*
1st point physical setpoint value	0.000*
Measure 2nd point	Measure 2nd point
2nd point physical actual value	100.000*
2nd point physical setpoint value	100.000*
Two-point scaling	Active; deactivated*
Rotational speed	
Unit	1/min*; rpm; 1/s; rad/s
Decimal point	.; .0; .00; .000*
Sign	Positive*; negative
Low-pass filter 1 (nominal value)	0.05 Hz; 0.1 Hz; 0.2 Hz; 0.5 Hz; 1 Hz; 2 Hz; 5 Hz; 10 Hz; 20 Hz; 50 Hz; 100 Hz; 200 Hz; 500 Hz; 1 kHz*; 2 kHz; 4 kHz
Low-pass filter 2 (nominal value)	0.05 Hz; 0.1 Hz; 0.2 Hz; 0.5 Hz; 1 Hz*; 2 Hz; 5 Hz; 10 Hz; 20 Hz; 50 Hz; 100 Hz
Angle of rotation	
Unit	degree*; rad
Decimal point	.; .0*; .00
Signal for zero balance	Speed sensor* (with reference pulse); Command* (without reference pulse)
Speed/angle of rotation output	
Measuring point name	<u>MySpeedMeasPnt</u>
Measuring point number	0
Mechanical increments	360*/720*
Signals F1/ F2	Frequency* Pulse (pos. edge) / direction of rotation Pulse (pos./neg. edge) / direction of rotation Pulse (4 edges) / direction of rotation
Output pulse division	1*; 2; 4; 6; 8; 12
Increments per revolution	360*/720*

Hysteresis for reversing the direction of rotation	On*; Off
Frequency output	
Signal	Torque low pass 1* Torque low pass 2*
Mode	10 +/- 5 kHz* 60 +/- 30 kHz*
1st point physical setpoint value	0.000* (depending on the nominal (rated) measuring range)
2nd point physical setpoint value	1000.000* (depending on the nominal (rated) measuring range)
1st point frequency	10.000000* (depending on the electrical configuration)
2nd point frequency	15.000000* (depending on the electrical configuration)
Analog output	
Signal	Torque low pass 1* Torque low pass 2* Rotational speed low pass 1* Rotational speed low pass 2*
Measuring point number	0
Mode	10 V*
1st point physical setpoint value	0.000*
2nd point physical setpoint value	1000.000*
1st point voltage	0.0000*
2nd point voltage	10.0000*
Power	
Unit	W; kW*; MW; hp
Decimal point	.; .0; .00; .000*
Low-pass filter (-1 dB)	0.1 Hz; 1 Hz*; 10 Hz; 100 Hz
SIGNAL CONDITIONING	
Torque	
Shunt	On; <u>Off</u> *
Shunt signal (of nominal value)	10%; 50%*

Zero signal compensation	Zero signal compensation	
Zero value	0.000*	
Angle of rotation		
Measurement range	0 to n x 360 degrees, pos. direction of rotation* 0 to n x 360 degrees, neg. direction of rotation 0 to -n x 360 degrees, pos. direction of rotation 0 to -n x 360 degrees, neg. direction of rotation -n x 360 to n x 360 degrees, pos. direction of rotation -n x 360 to n x 360 degrees, neg. direction of rotation	
Number of revolutions n	1*; 2; 3; 4	
ADDITIONAL FUNCTIONS		
Limit values		
Limit value 1		
Monitoring	On; Off*	On; Off*
Signal	Torque low pass 1* Torque low pass 2	Rotational speed low pass 1* Rotational speed low pass 2*
Switching direction	Overshoot* Undershoot	Overshoot* Undershoot
Level	10.000*	10.0*
Hysteresis	0.500*	0.5*
Limit value 2		
Monitoring	On; Off*	On; Off*
Signal	Torque low pass 1* Torque low pass 2	Rotational speed low pass 1* Rotational speed low pass 2*
Switching direction	Overshoot* Undershoot	Overshoot* Undershoot
Level	10.000*	10.0*
Hysteresis	0.500*	0.5*
Limit value 3		
Monitoring	On; Off*	On; Off*
Signal	Torque low pass 1* Torque low pass 2	Rotational speed low pass 1* Rotational speed low pass 2*
Switching direction	Overshoot Undershoot*	Overshoot Undershoot*

Level	-10.000*	-10.0*
Hysteresis	0.500*	0.5*
Limit value 4		
Monitoring	On; Off*	On; Off*
Signal	Torque low pass 1* Torque low pass 2	Rotational speed low pass 1* Rotational speed low pass 2*
Switching direction	Overshoot Undershoot*	Overshoot Undershoot*
Level	-10.000*	-10.0*
Hysteresis	0.500*	0.5*
SAVE/LOAD PARAMETERS		
Loading from the transducer		
Select parameter set	1*; 2; 3; 4; factory settings	
Saving to the transducer		
Select parameter set	1; 2; 3; 4	
Torque TEDS template	<u>HBM Frequency Sensor*</u> High Level Voltage Output	
Speed/angle of rotation output	<u>HBM Frequency Sensor*</u> HBK Pulse Sensor	

21 ORDERING NUMBERS

Ordering number:	
K-T12HP	
Code	Option 1: Measurement range
S100Q	100 N·m
S200Q	200 N·m
S500Q	500 N·m
S001R	1 kN·m
S002R	2 kN·m
S003R	3 kN·m
S005R	5 kN·m
S010R	10 kN·m
Code	Option 2: Components
MF	Complete measurement flange
RO	Rotor
ST	Stator
Code	Option 3: Accuracy
0	No stator option
S	Standard accuracy (lin. $\leq\pm 0.015\%$; $TC_0 \leq\pm 0.010\%/10K$) $CT=0.02\%$
U	High accuracy (lin. $\leq\pm 0.007\%$; $TC_0 \leq\pm 0.005\%/10K$) $CT=0.02\%$
W	High accuracy (lin. $\leq\pm 0.007\%$; $TC_0 \leq\pm 0.005\%/10K$) $CT=0.01\%$
Code	Option 4: Nominal (rated) rotational speed
0	No stator option
L	10,000-15,000 rpm, rel. to meas. range
H	12,000-18,000 rpm, rel. to meas. range
F	18,000-22,000 rpm, rel. to meas. range (available exclusively for measuring ranges 100 Nm to 3 kNm)
Code	Option 5: electrical configuration
000	No rotor option
DF1	Output 60kHz \pm 30kHz
DU2	Output 60kHz \pm 30kHz and \pm 10V
SF1	Output 10kHz \pm 5kHz
SU2	Output 10kHz \pm 5kHz and \pm 10V

K-T12HP - S500Q - MF - S - L - SU2 - C - N - N - U

Ordering example (continued on the next page)

Code	Option 6: Bus connection
0	No rotor option
C	CANopen
P	CANopen and Profibus DPV1

Code	Option 7: Rotational speed measuring system
N	No rotational speed measuring system
1	Optical
A	Optical with reference pulse

Code	Option 8: Protection against contact
N	Without protection against contact
Y	With protection against contact

Code	Option 9: Customized modification
U	None

K-T12HP -

S	5	0	0	Q
---	---	---	---	---

 -

M	F
---	---

 -

S

 -

L

 -

S	U	2
---	---	---

 -

C

 -

N

 -

N

 -

U

Ordering example (continued from previous page)

22 ACCESSORIES

Article	Ordering number
Connection cable, set	
Torque	
Torque connection cable, Binder 423 7-pin D-Sub 15-pin, 6 m	1-KAB149-6
Torque connection cable, Binder 423 free ends, 6 m	1-KAB153-6
Rotational speed	
Rotational speed connection cable, Binder 423 8-pin D-Sub 15-pin, 6 m	1-KAB150-6
Rotational speed connection cable, Binder 423 8-pin free ends, 6 m	1-KAB154-6
Rotational speed connection cable, reference signal, Binder 423 8-pin D-Sub 15-pin, 6 m	1-KAB163-6
Rotational speed connection cable, reference signal, Binder 423 8-pin free ends, 6 m	1-KAB164-6
CAN bus	
CAN bus M12 connection cable, A-coded - D-Sub 9-pin, switchable termination resistor, 6 m	1-KAB161-6
Plugs/sockets	
Torque	
423G-7S, 7-pin cable socket, straight cable entry, for torque output (plug 1, plug 3)	3-3101.0247
423W-7S, 7-pin cable socket, 90° cable entry, for torque output (plug 1, plug 3)	3-3312.0281
Rotational speed	
423G-8S, 8-pin cable socket, straight cable entry, for rotational speed output (plug 2)	3-3312.0120
423W-8S, 8-pin cable socket, 90° cable entry, for rotational speed output (plug 2)	3-3312.0282
CAN bus	
TERMINATOR M12/termination resistor, M12, A-coded, 5-pin, plug	1-CANHEAD-TERM
Termination resistor, CAN bus M12, A-coded, 5-pin, socket	1-CAN-AB-M12
T-SPLITTER M12/T-piece M12, A-coded, 5-pin	1-CANHEAD-M12-T

Article	Ordering number
Cable plug/socket/CAN bus M12, cable socket 5-pin M12, A-coded, cable plug 5-pin M12, A-coded	1-CANHEAD-M12
PROFIBUS	
Connection cable, Y-splitter, M12 socket, B-coded; M12 plug, B-coded; M12 socket, B-coded, 2 m	1-KAB167-2
Cable plug/socket/PROFIBUS M12, cable socket 5-pin M12, B-coded, cable plug 5-pin M12, B-coded	1-PROFI-M12
Termination resistor PROFIBUS M12, B-coded, 5-pin	1-PROFI-AB-M12
T-piece PROFIBUS M12, B-coded, 5-pin	1-PROFI-VT-M12
Connection cable, by the meter	
Kab8/00-2/2/2	4-3301.0071
Kab8/00-2/2/2/1/1	4-3301.0183
DeviceNet cable	4-3301.0180
Other	
Setup toolkit for T12HP (System-CD T12HP, PCAN-USB adapter, CAN bus connection cable, 6 m)	1-T12-SETUP-USB

23 COMPATIBILITY BETWEEN T12HP AND T12

Our products are constantly being developed and improved. In the case of the T12HP, it was necessary to raise the hardware revision level of both the rotor and stator from 1.xx to 2.xx.

The new hardware revision version impacts on the compatibility with older models, and therefore the hardware revision versions of type T12.

If there is incompatibility, torque measurement becomes impossible.

i Information

In cases of incompatibility, all the torque-related outputs are set to “invalid” for safety reasons.

i Information

The current hardware version for the torque transducer (rotor/stator) used can be found in the T12 Assistant under the heading Type Description.

Parameter	Value
Gerätefamilie	Smart torque
Drehmomtaufnehmer	T12
Code-Nr.	K-T12-S001R-S-L-DU2-P-A-N-
Nennmoment	1000
Shuntsignal 1	CALSig1
Shuntsignal 2	CALSig2
Maximalschzahl	16000
Zeit/Nr. Stator	123912007
Hardwareversion Stator	1.22
Hardwareversion Rotor	1.16
Logiversion FPGA	S0
Programmversion FPGA	16
Hardwareversion Stator	4.02
Hardwareversion Rotor	2.50
Programmversion Rotor CPLD	2
Zeit/Nr. Rotor	200650072
TEDS-Seriennummer Drehmoment	236ED8350100007A
TEDS-Seriennummer Drehzahl/Drehwinkelausgang	2335D835010000AC

Fig. 23.1 Type description with the current hardware revision version

The product version currently being used can also be seen on the type plate of the rotor and stator.

104

T12HP
COMPATIBILITY BETWEEN T12HP AND T12

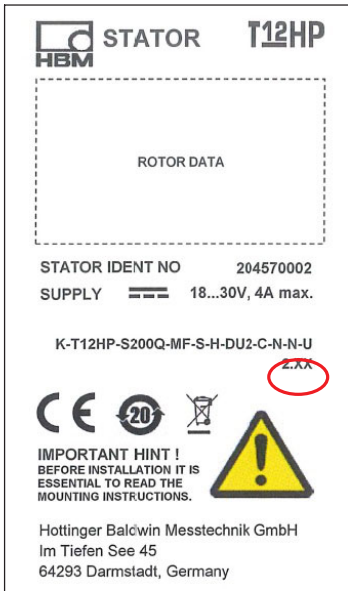

Fig. 23.2 Stator sticker: stator hardware revision version

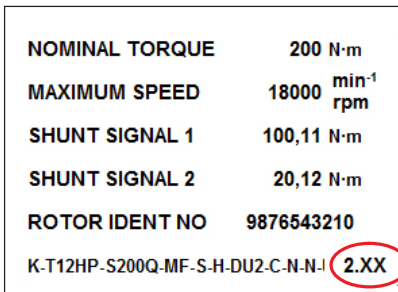

Fig. 23.3 Stator sticker: rotor hardware revision version

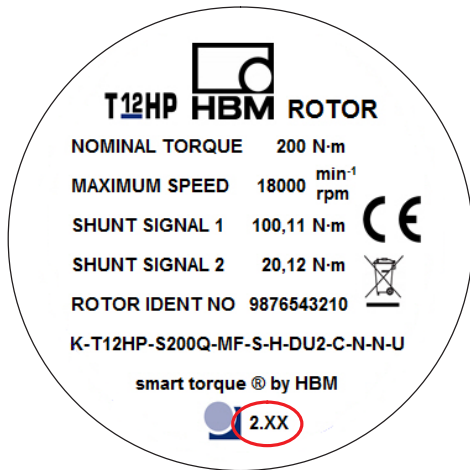

Fig. 23.4 Rotor sticker: rotor hardware revision version

The HW revision version that is read with the T12 Assistant does not necessarily have to match the product version on the rotor and stator type plate. It is important when using the T12HP that the first number of the revision versions is not greater than 2.xx.



The T12HP is compatible with its predecessor, the T12 model, in the vast majority of cases with regard to interconnecting the rotor and stator. Combinations that could occur in practice are shown below.



i Information



Change of the position of the reference pulse sensor/marker on the stator

On the stator with hardware version 1.xx and 2.xx, sampling of the reference marker was implemented axially on the rotational speed ring. From hardware version 3.xx onwards, sampling is implemented radially on the transmitter. For this purpose, the magnet is located within the winding of the rotor and the sampling sensor is integrated in the stator head, so that neither are visible from the outside.

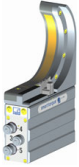
Compatibility tables

T12 stator	T12HP rotor	Compatibility
		
HW rev. 1.xx	HW rev. 2.xx	NOK Measured values set to invalid LED on the stator glows red
HW rev. 2.xx	HW rev. 2.xx	OK
HW rev. 2.xx	HW rev. 3.xx	OK

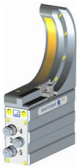
T12HP stator	T12 rotor	Compatibility
		
HW rev. 2.xx	HW rev. 1.xx	OK
HW rev. 2.xx	HW rev. 2.xx	OK
HW rev. 3.xx	HW rev. 1.xx	NOK Reference pulse has no function
HW rev. 3.xx	HW rev. 2.xx	OK

T12HP stator	T12HP rotor	Compatibility
		All T12HP stators and T12HP rotors can be combined with each other, irrespective of their hardware version!
HW rev. 2.xx	HW rev. 2.xx	OK
HW rev. 2.xx	HW rev. 3.xx	OK
HW rev. 3.xx	HW rev. 2.xx	OK
HW rev. 3.xx	HW rev. 3.xx	OK

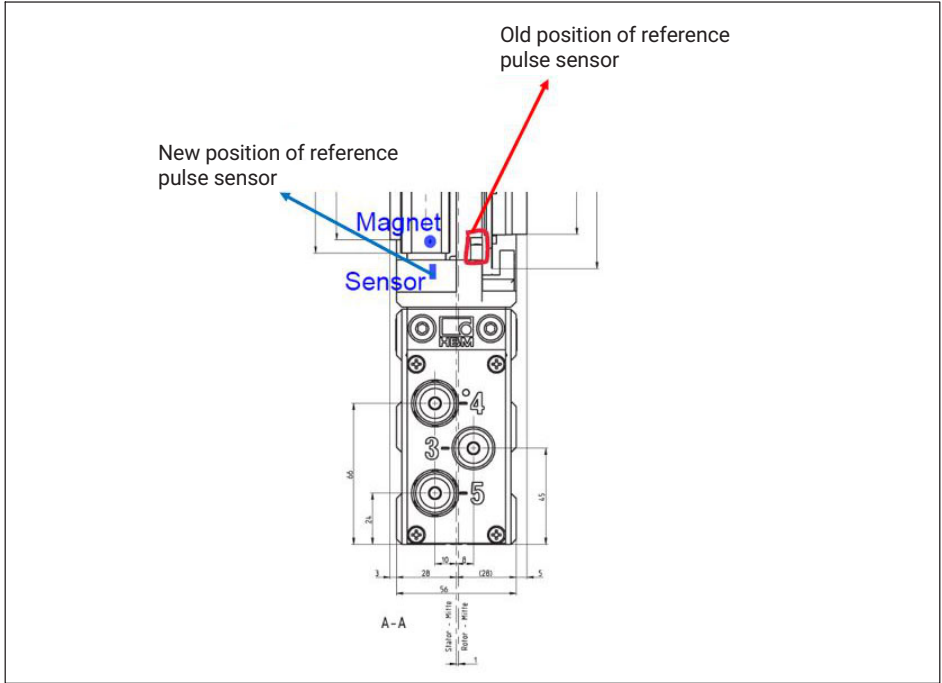
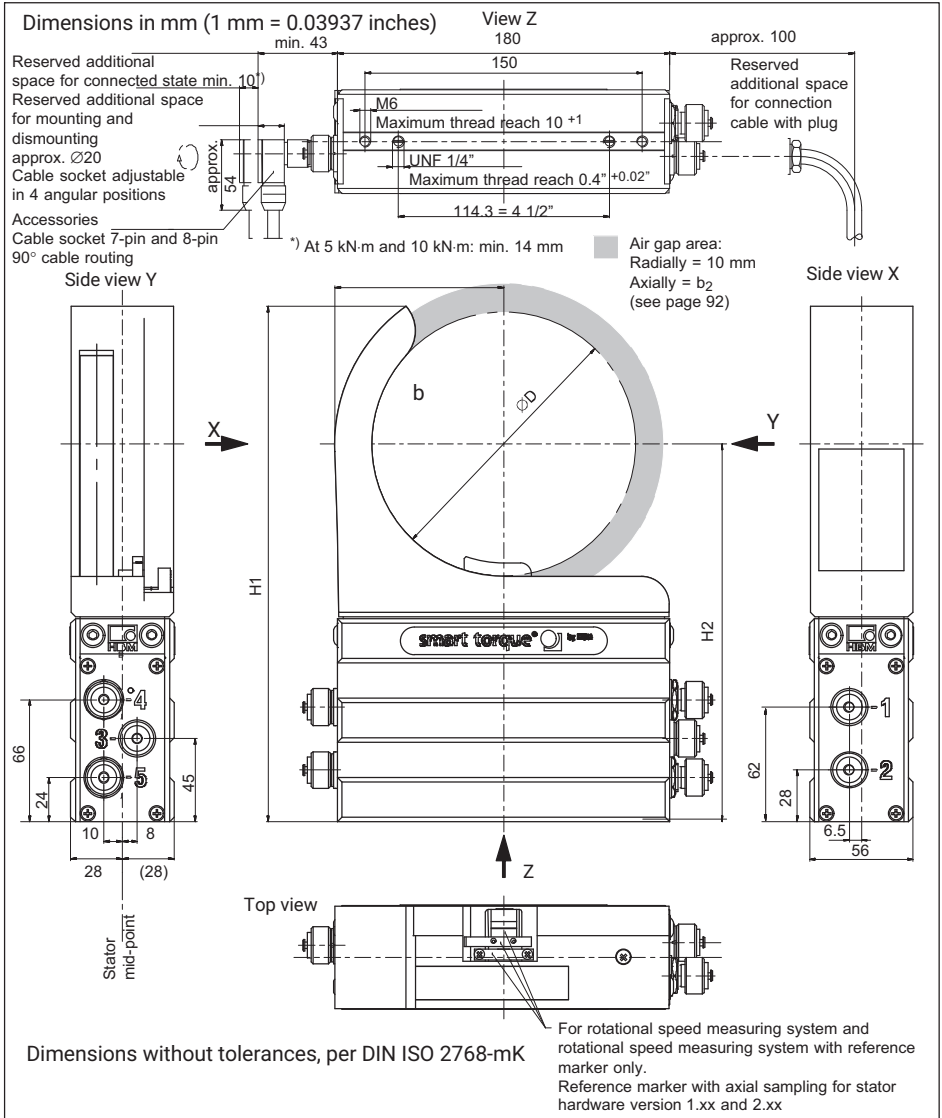

Fig. 23.5 New position of the reference pulse sensor, valid from stator hardware version 3.xx

24 DIMENSIONS

Stator 100 N·m to 10 kN·m with rot. speed meas. system Reference marker/sensor with stator hardware version 1xx and 2.xx



Measuring range (N·m)	Dimensions in mm (1 mm = 0.03937 inches)			
	b	∅D	H1	H2
100 200	81	122	260	194.5
500 1 k	91.5	143	280	204.5
2 k 3 k	109.5	179	310	222.5
5 k	123.5	207	333	239.5
10 k	144.5	249	369	263.5

Complete measurement flange, T12HP/100 Nm to 200 Nm, with rotational speed measuring system

Reference marker/sensor with stator hardware version 1xx and 2.xx

Dimensions in mm
(1 mm = 0.03937 inches)

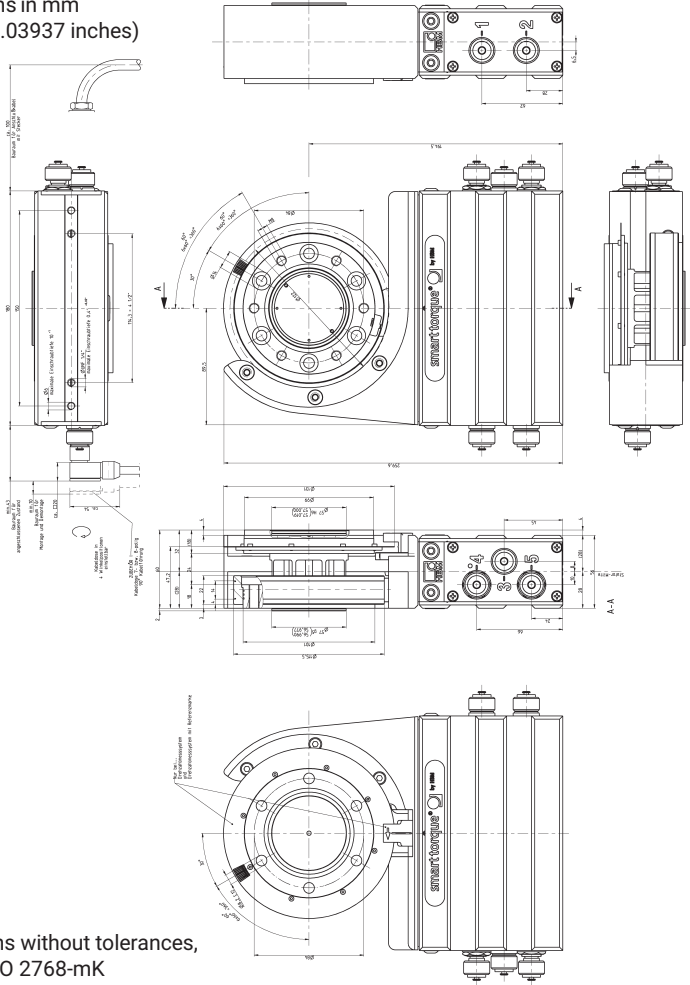

Dimensions without tolerances,
per DIN ISO 2768-mK

Complete measurement flange, T12HP/500 Nm to 1 kNm, with rotational speed measuring system
Reference marker/sensor with stator hardware version 1xx and 2.xx

Dimensions in mm
 (1 mm = 0.03937 inches)

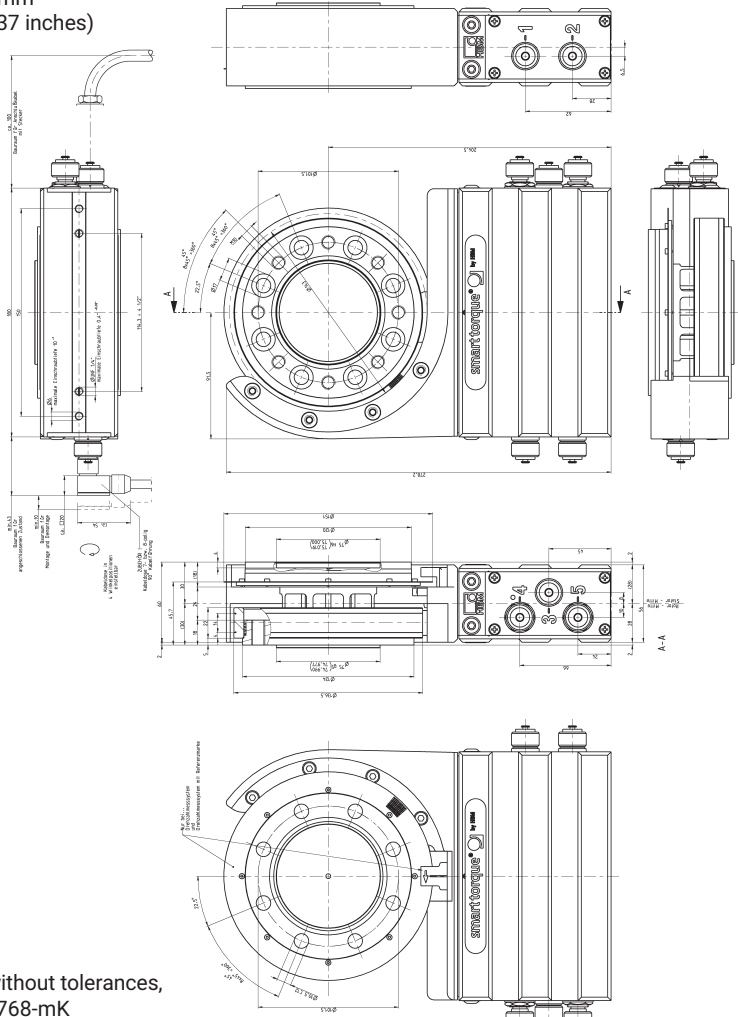

Complete measurement flange, T12HP/2 to 3 kNm, with rotational speed measuring system
Reference marker/sensor with stator hardware version 1xx and 2.xx

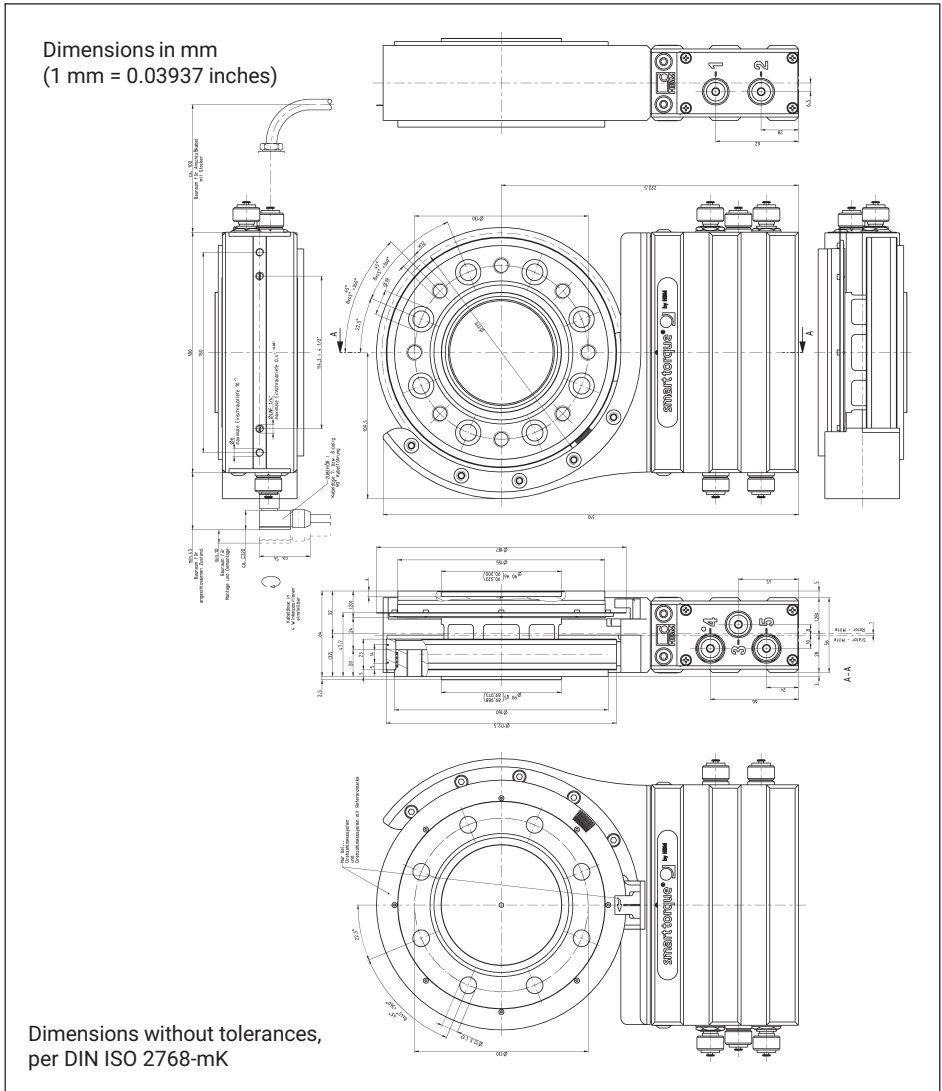

Protection against contact plates 100 N·m ... 200 N·m

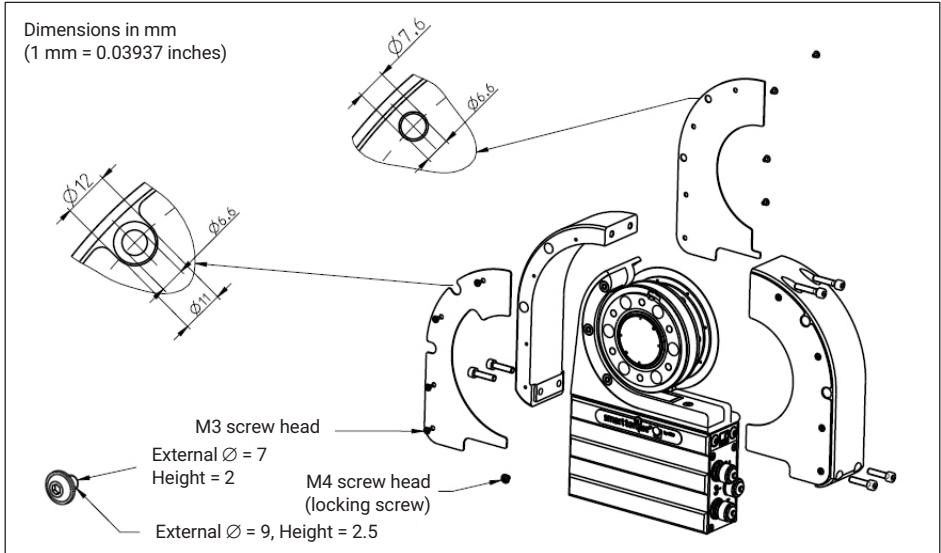

Protection against contact plates 0,5 kN·m ... 1 kN·m

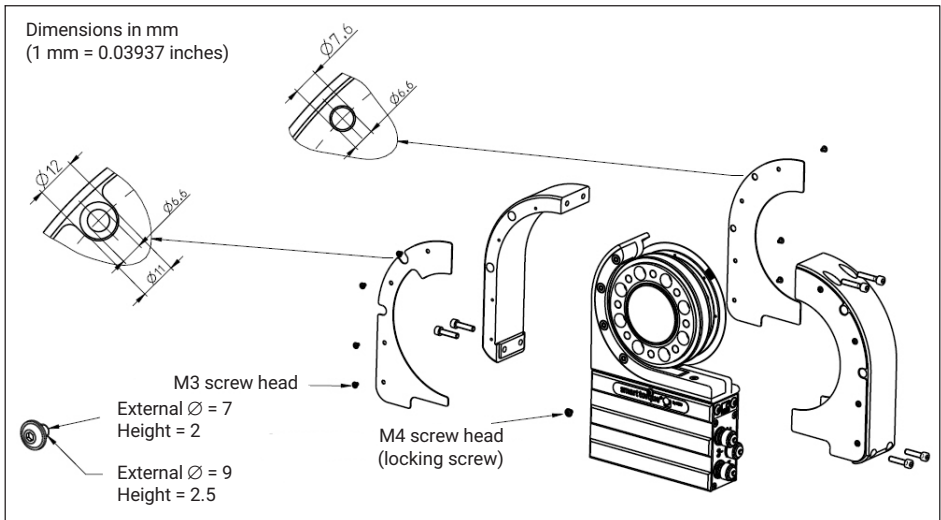

Protection against contact plates 2 kN-m ... 3 kN-m

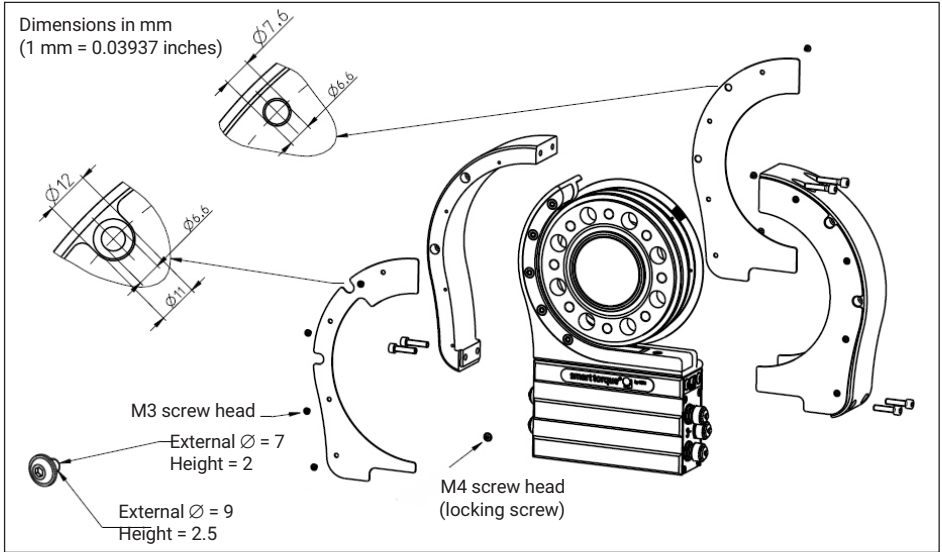

Protection against contact plates 5 kN-m ... 10 kN-m

