

TB2

Torque reference transducer

Special features

- Accuracy class 0.02
- Nominal (rated) torques 100 N·m, 200 N·m, 500 N·m, 1 kN·m, 2 kN·m, 3 kN·m, 5 kN·m and 10 kN·m
- High permissible oscillation stress
- In combination with German Calibration Service calibration certificate, class 0.05 as per DIN 51309 or EA-10/14
- Optional: Degree of protection IP67 as per EN 60529



Standard version



Optional: Degree of protection IP67

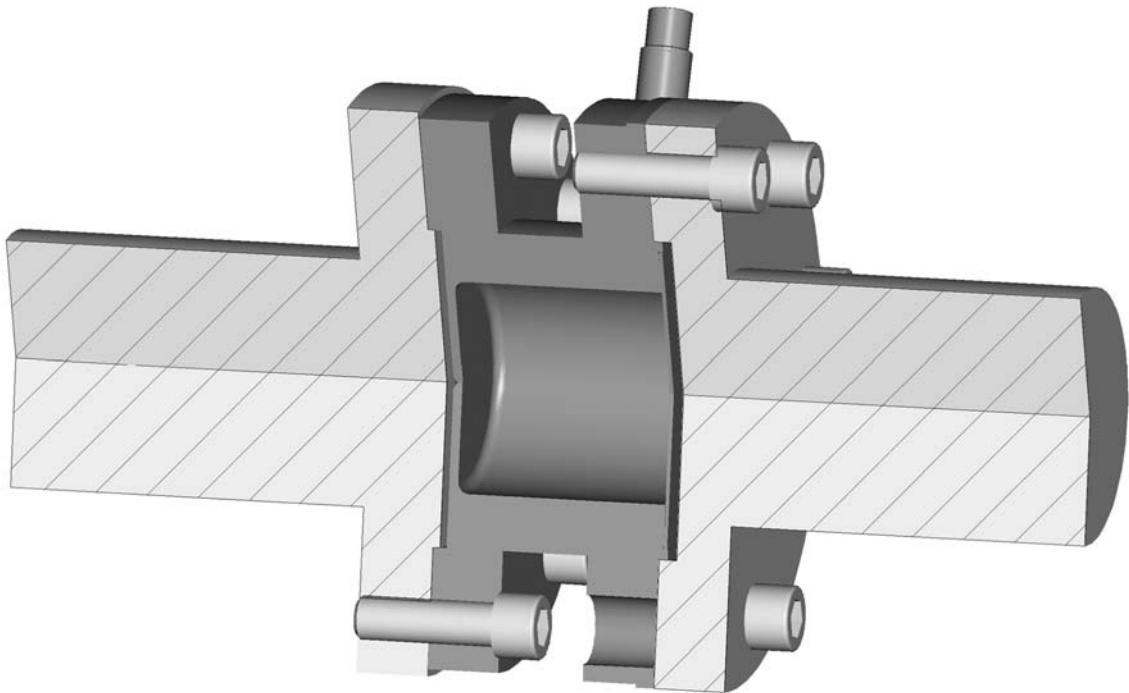

Specifications

Type		TB2							
Accuracy class		0.02							
Nominal (rated) torque M_{nom}	N·m	100	200	500					
	kN·m				1	2	3	5	10
Nominal sensitivity (spread between torque = zero and nominal (rated) torque)		mV/V							
		1							
Sensitivity tolerance (deviation of the actual output quantity at M_{nom} from the nominal (rated) sensitivity)		%							
		<±0.1							
Temperature effect per 10K in the nominal (rated) temperature range									
on the output signal, relative to the actual value		%							
on the zero signal relative to the nominal (rated) sensitivity		%							
		<±0.02							
		<±0.01							
Linearity deviation including hysteresis relative to the rated output (nominal)									
for max. torque in the range:									
between 0 % of M_{nom} and 20 % of M_{nom}		%							
>20 % of M_{nom} and 60 % of M_{nom}		<±0.004							
>60 % of M_{nom} and 100 % of M_{nom}		<±0.006							
		<±0.01							
Relative standard deviation of repeatability									
as per DIN 1319, relative to the variation of the output signal		%							
		<±0.005							
Input resistance at reference temperature		Ω							
		1550 ±100							
Output resistance at reference temperature		Ω							
		900 ... 1500							
Reference excitation voltage		V							
		5							
Operating range of the excitation voltage		V							
		2.5 ... 12							
Emission (EME) in accordance with (EN 61326-1, table 4)									
RFI field strength		Class B							
Immunity to interference (EN 61326-1, table A.1)									
Electromagnetic field (AM)		V/m							
		10							
Magnetic field		A/m							
		100							
Electrostatic discharge (ESD)									
Contact discharge		kV							
		4							
Air discharge		kV							
		8							
Burst (fast transients)		kV							
		2							
Surge (impulse voltages)		kV							
		1							
Conducted interference		V							
		10							
Degree of protection as per EN 60 529		-							
		IP54, optionally IP67							
Nominal (rated) temperature range		°C							
		+10 ... +60							
Operating temperature range		°C							
		-10 ... +80							
Storage temperature range		°C							
		-50 ... +85							
Mechanical shock and impact testing per EN 60068-2-27; IEC 68-2-27-1987									
Number		n							
		1000							
Duration		ms							
		3							
Acceleration (half sine)		m/s ²							
		650							
Vibration testing per EN 60068-2-6; IEC 68-2-6-1982									
Frequency range		Hz							
		5 ... 65							
Duration		h							
		1.5							
Acceleration (amplitude)		m/s ²							
		50							
Load limits¹⁾									
Torque limit , relative to M_{nom}		%							
		200				160			
Breaking torque , relative to M_{nom}		%							
		400				320			

Type		TB2							
Accuracy class		0.02							
Nominal (rated) torque M_{nom}	N·m	100	200	500					
	kN·m				1	2	3	5	10
Longitudinal limit force	kN	5	10	16	19	39	42	80	120
Lateral limit force	kN	1	2	4	5	9	10	12	18
Bending moment limit	N·m	50	100	200	220	560	600	800	1200
Oscillation width as per DIN 50100 (peak-to-peak)	N·m	200	400	1000	2000	4000	4800	8000	16000
Mechanical values									
Nominal (rated) torque M_{nom}	N·m	100	200	500					
	kN·m				1	2	3	5	10
Torsional stiffness	kN·m/ rad	230	270	540	900	2300	2600	4600	7900
Torsion angle at M_{nom}	degrees	0.048	0.043	0.055	0.066	0.049	0.066	0.06	0.07
Stiffness in axial direction, approx.	kN/mm	420	800	900	970	1000	1100	950	1600
Stiffness in radial direction, approx.	kN/mm	130	290	700	840	1400	1600	1400	2500
Stiffness with the bending moment about a radial axis	N·m/rad	66	120	165	170	380	390	550	1240
Maximum deflection at axial limit force	mm	0.02		< 0.03		< 0.05		< 0.1	
Additional max. radial deviation at lateral limit force	mm	< 0.01							
Additional deviation from plane parallelism at bending moment limit	mm	< 0.03		< 0.04		< 0.06		< 0.1	
Mass moment of inertia (without taking flange bolts into account) of the rotor I_v (about the longitudinal axis)	kg·m ² 10 ⁻³	1.6	2.6	5.9		19.2		37	97
Proportional mass moment of inertia (measuring side)	%	56		55		52		50	
Position of SG level (as distance to level of adaption surface of flange with external centering)	% of total length	50							
Weight, approx. (excl. cable)	kg	0.7	1.7	2.4		4.9		8.3	14.6
Weight, IP67 version, approx. (incl. cable)	kg	0.9	1.9	2.6		5.1		8.5	14.8

Supplementary data as per DIN 51309 or EA 10/14		
Class as per DIN 51309		0.05
Rel. zero error (zero signal return)	%	< ± 0.008 (typical < 0.003)
Rel. reproducibility and repeatability errors (0.2 M_{nom} to M_{nom}) for		
a constant mounting position	%	< 0.02 (typical < 0.01)
a changing mounting position	%	< 0.03 (typical < 0.02)
Rel. hysteresis error (0.2 M_{nom} to M_{nom})	%	< 0.06 (typical < 0.03)

1) Each type of irregular stress (bending moment, lateral or longitudinal force, exceeding nominal (rated) torque) can only be allowed up to its specified limit, provided none of the others can occur at the same time. If this condition is not met, the limit values must be reduced. If 30% of the bending moment limit and lateral limit force occur at the same time, only 40% of the axial limit force is allowed and the nominal (rated) torque must not be exceeded. The effects of 10% of the allowed bending moments, axial and lateral forces on the measurement result are $\leq \pm 0.02\%$ of the nominal (rated) torque

Standard version (dimensions in mm)

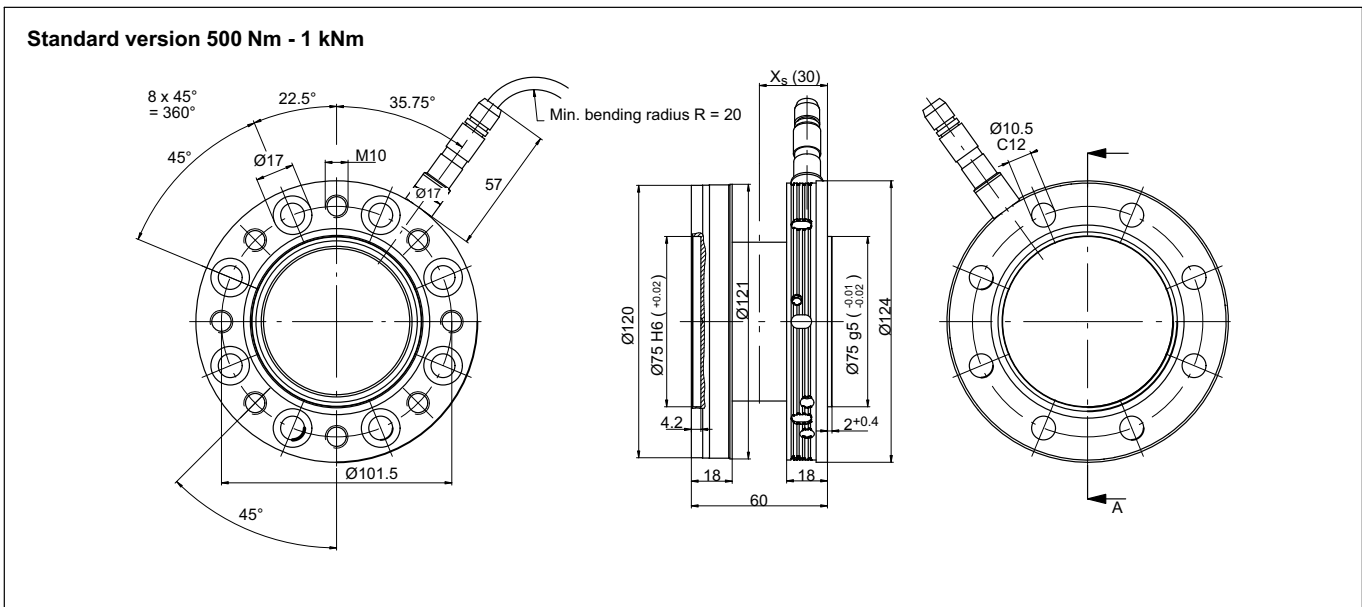
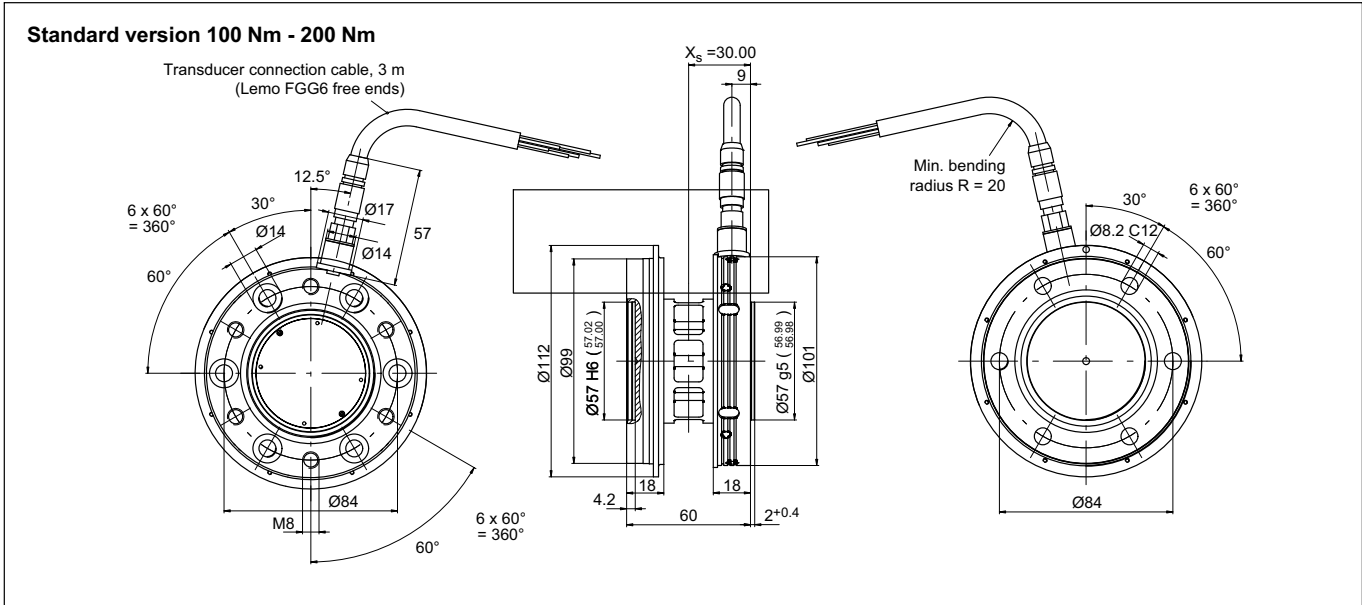

Standard version 2 kNm - 3 kNm

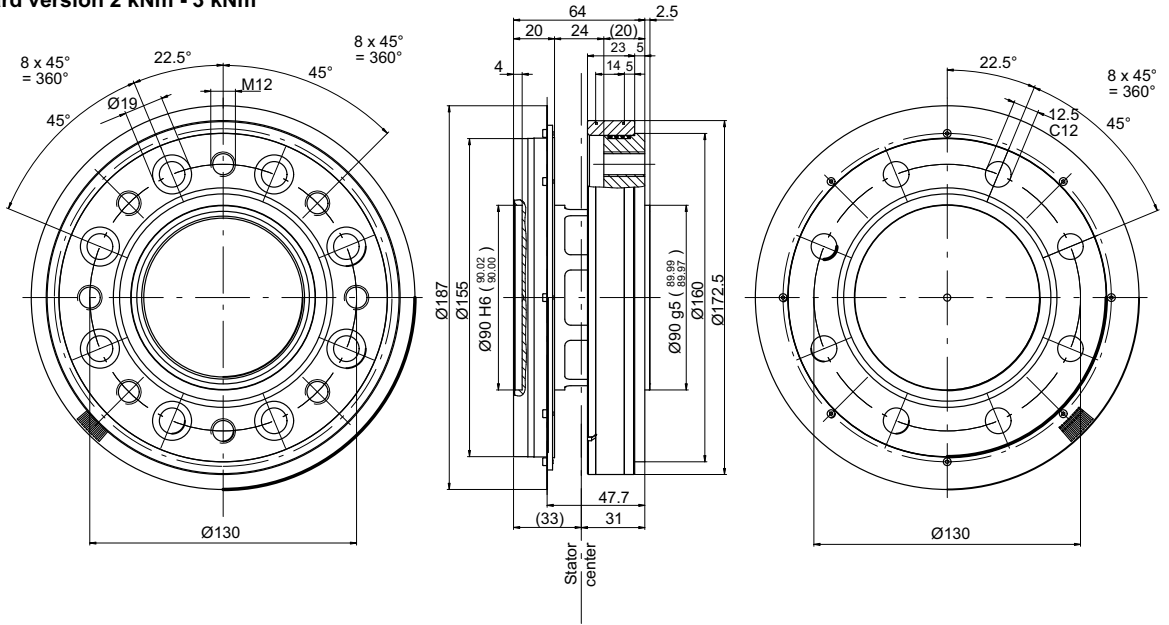

Standard version 5 kNm

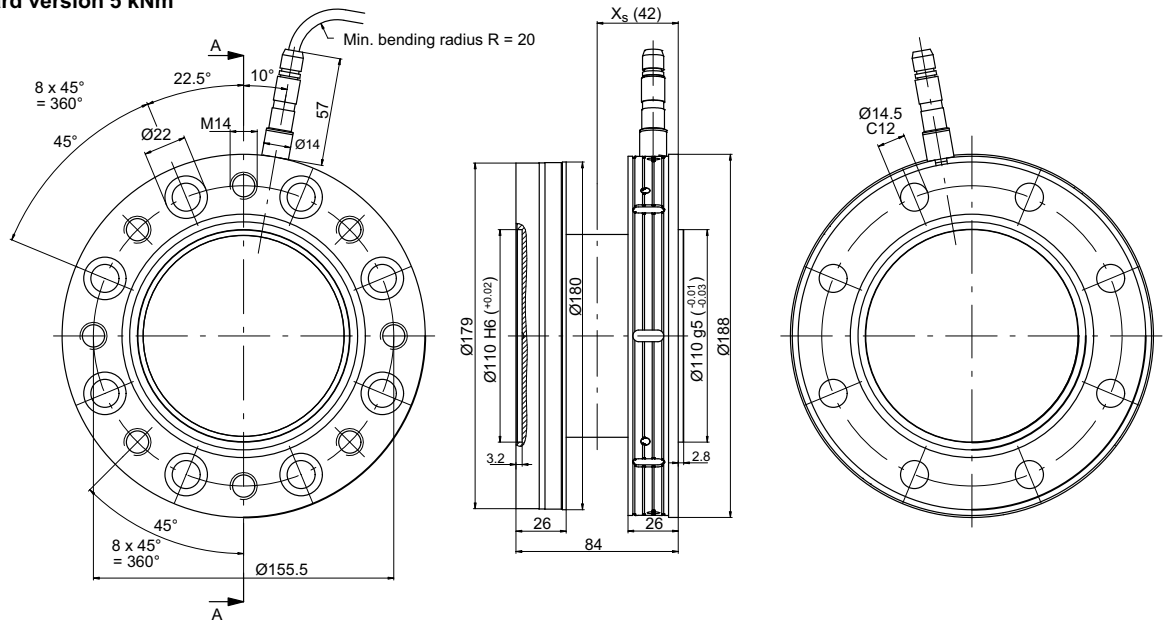

Standard version 10 kNm

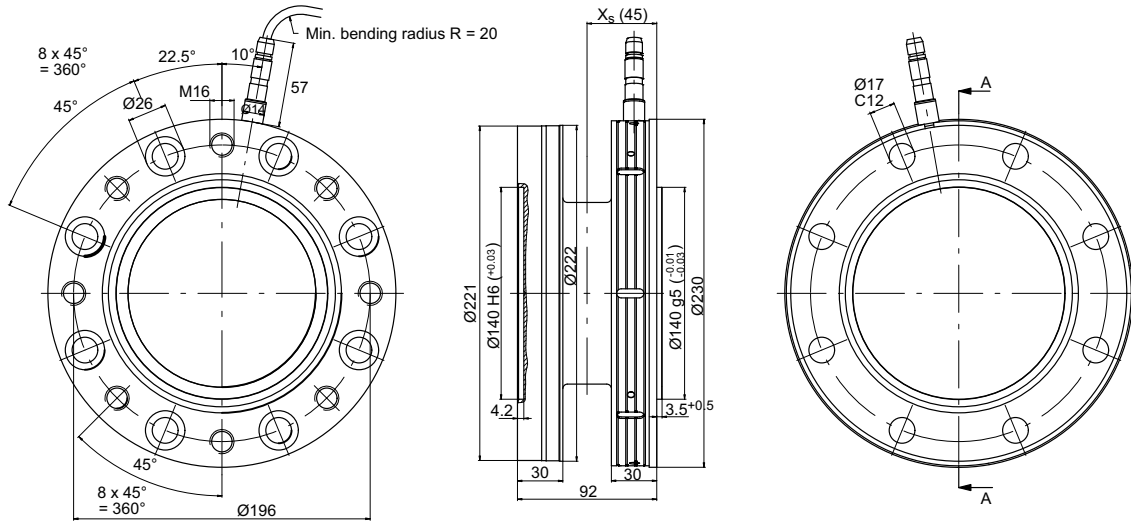

Option: Degree of protection IP67 (dimensions in mm)

Option: Degree of protection IP67, 100 Nm - 200 Nm

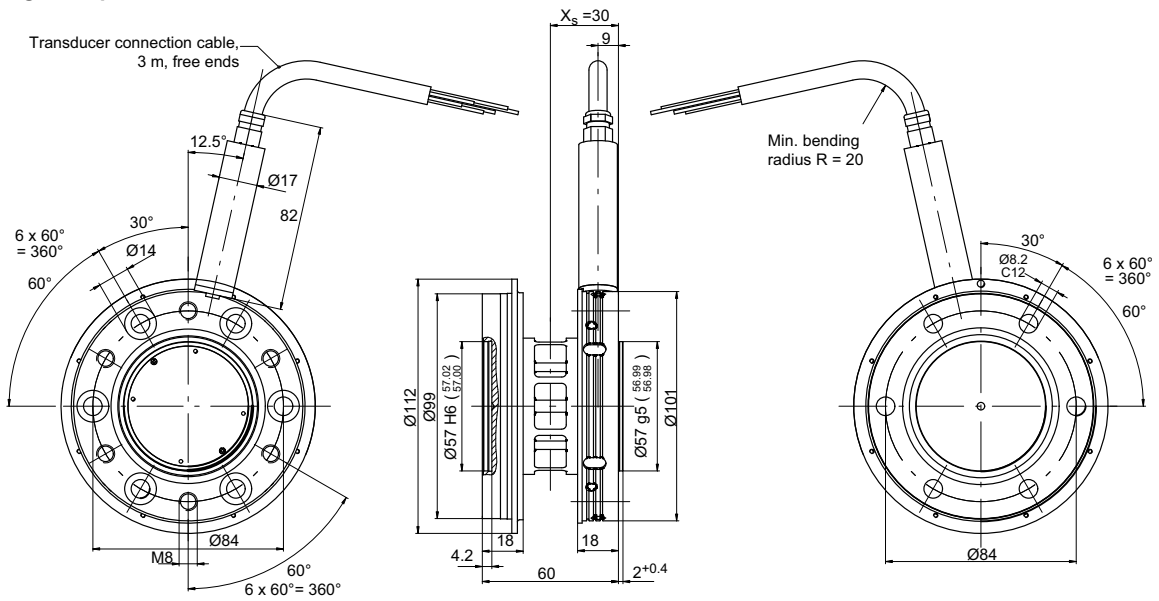

Option: Degree of protection IP67, 500 Nm - 1 kNm

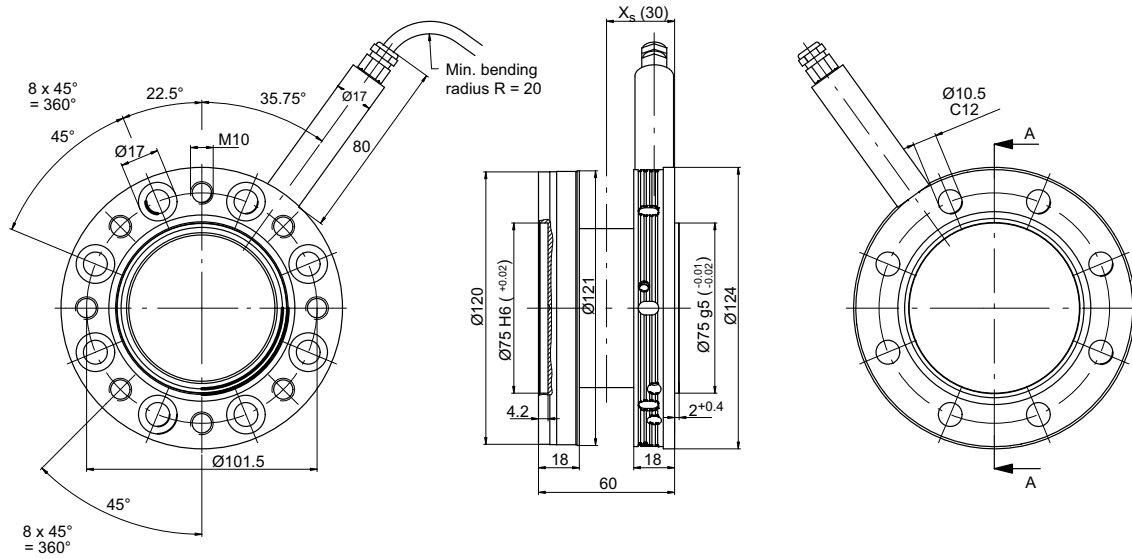

Option: Degree of protection IP67, 2 kNm - 3 kNm

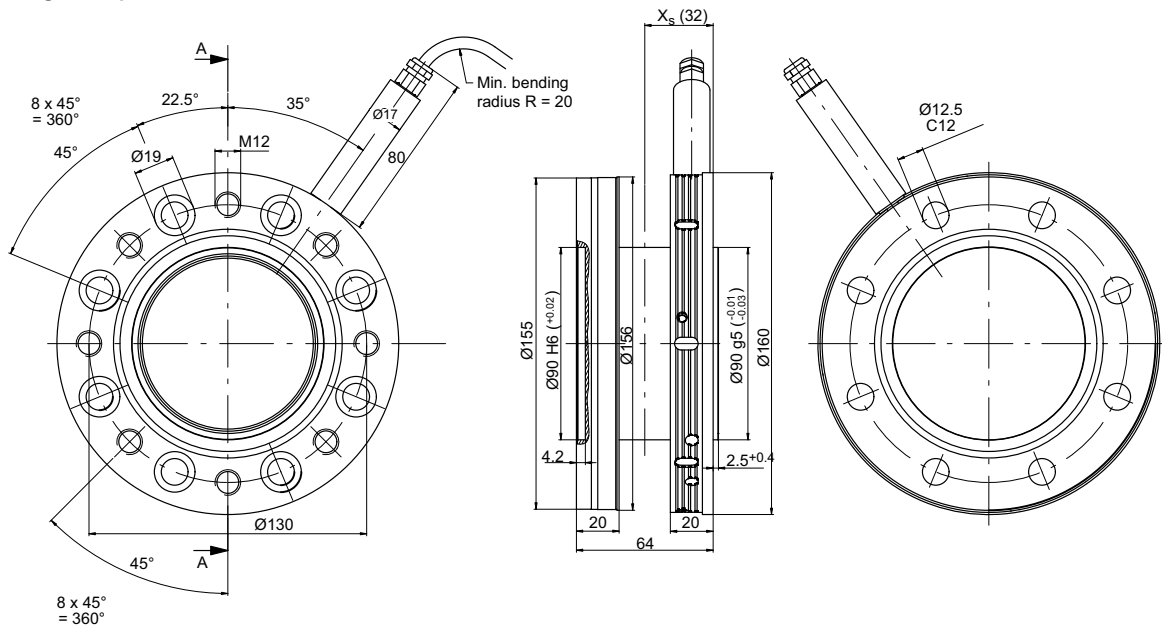

Option: Degree of protection IP67, 5 kNm

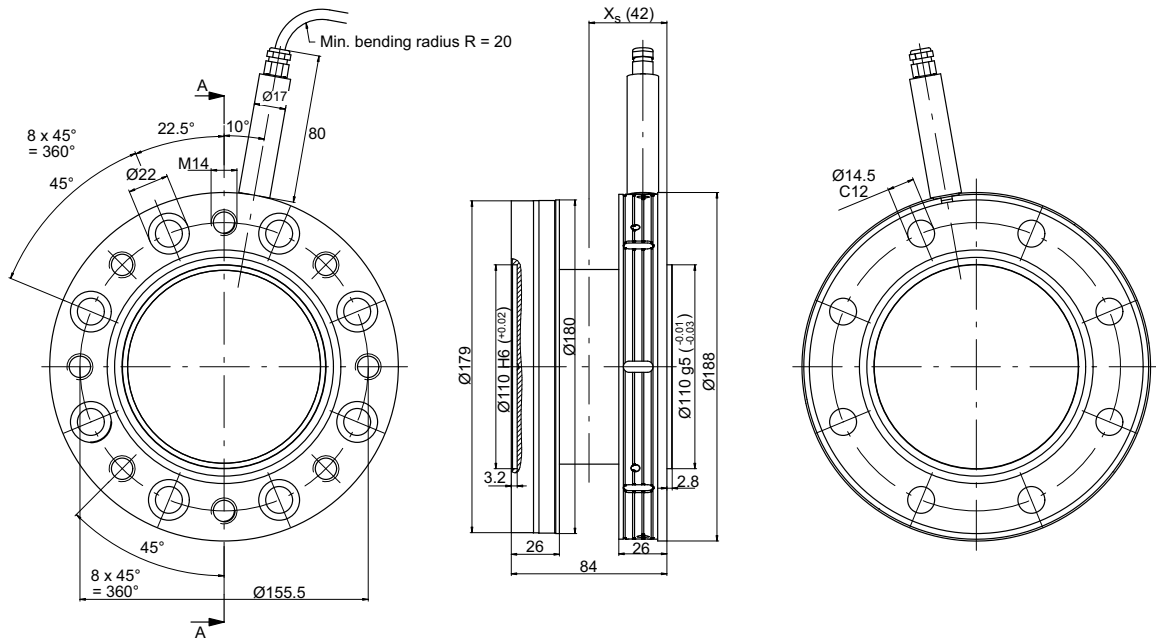

Option: Degree of protection IP67, 10 kNm

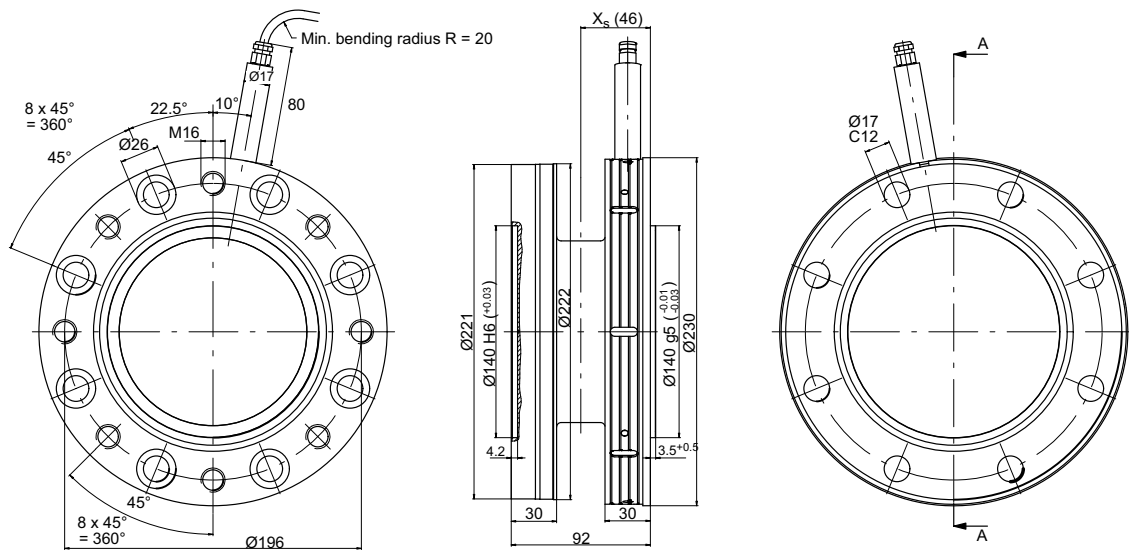

Scope of supply

- TB2
- Transducer connection cable, 3m, (Lemo® FGG6-free ends)
- Test record
- Mounting instructions

Option

Degree of protection IP67 as per EN 60529

Ordering no.: D-TB2/IP67

Accessories

- Connector plug MS 3106PEMV, mounted on cable Ordering no.: D-MS/MONT
- 15-pin D-plug, mounted on cable Ordering no.: D-15D/MONT
- Calibration certificate from German Calibration Service as per DIN 51309 or EA-10/14:

Axial and radial run-out tolerances

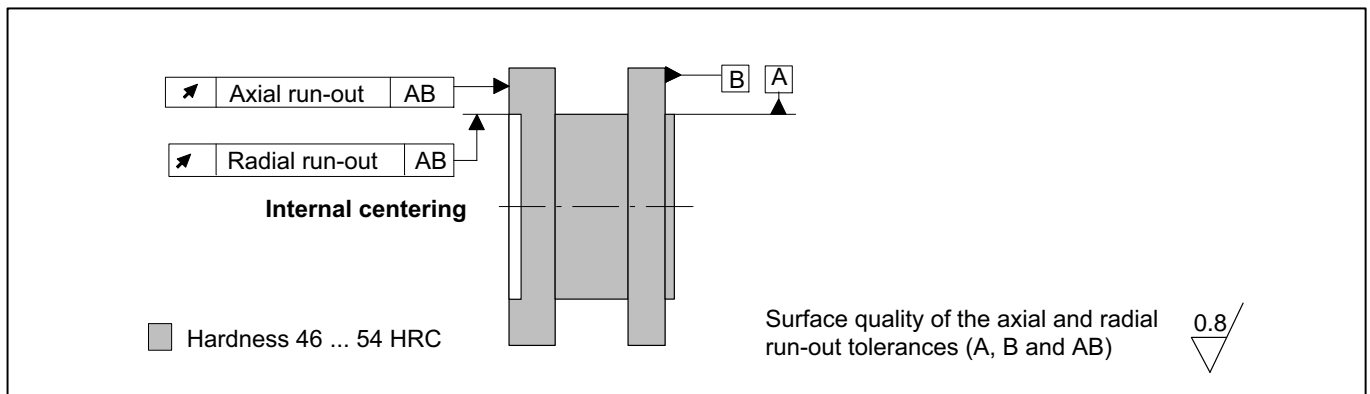

Measurement range	Axial run-out tolerance (mm)	Radial run-out tolerance (mm)
100 N·m - 1 kN·m	0.01	0.01
2 kN·m - 10 kN·m	0.02	0.02

Subject to modifications.
All product descriptions are for general information
only. They are not to be understood as a guarantee
of quality or durability.

Hottinger Baldwin Messtechnik GmbH
Im Tiefen See 45 · 64293 Darmstadt · Germany
Tel. +49 6151 803-0 · Fax +49 6151 803-9100
E-mail: info@hbm.com · www.hbm.com

measure and predict with confidence

