

SP4M... Single point load cells

with
 **IO-Link**
option

SPECIAL FEATURES

- Maximum capacities: 1 kg ... 200 kg
- Aluminum
- High ratio of minimum verification interval Y
- Off-center load compensation
- Shielded connection cable
- Explosion protection and other options deliverable
- Available as LCMC measurement chain with smart option (IO-Link), with digital option (CANopen or RS-485), with analog option (4 ... 20 mA or 0 ... 10 V)

precix 

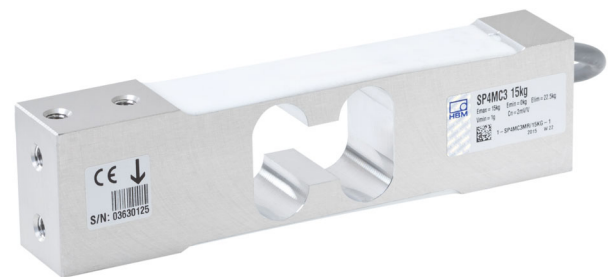

DIMENSIONS

Dimensions in mm (1 mm = 0.03937 inches)

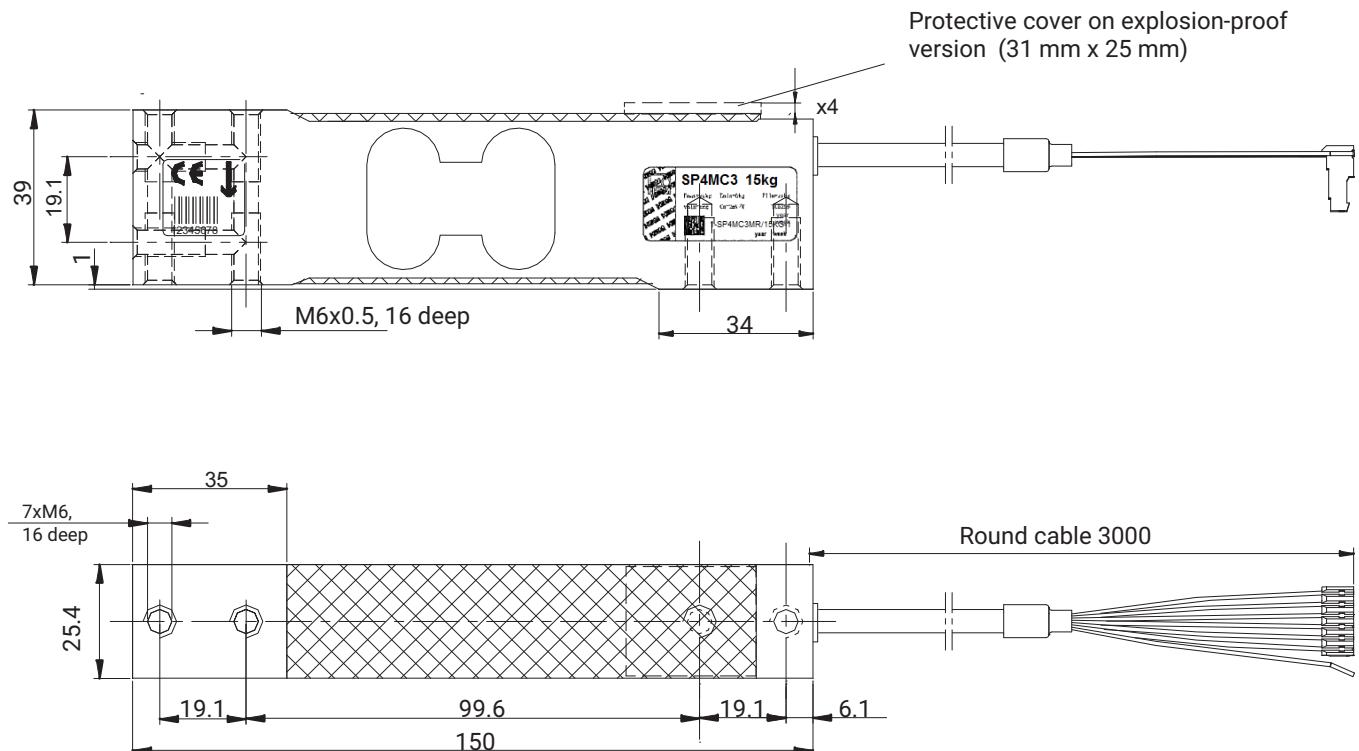

SPECIFICATIONS

Type			SP4M...												
Accuracy class as per OIML R60			C3 Multi Range (MR)												
Number of load cell verification intervals	n_{LC}		3000												
Maximum capacity ²⁾	E_{max}	kg	1	3	5	7	10	15	20	30	50	75	100	150	200
Minimum load cell verification interval	v_{min}	g	0.1	0.2	0.5	0.5	1	1	2	2	5	5	10	10	20
Temperature coefficient of zero signal	TC_0	% of $C_n/10\text{ K}$	± 0.0140	± 0.0093	± 0.0140	± 0.0100	± 0.0140	± 0.0093	± 0.0140	± 0.0093	± 0.0140	± 0.0093	± 0.0140	± 0.0093	± 0.0140
Ratio of minimum verification interval	Y		10000	15000	10000	14000	10000	15000	10000	15000	10000	15000	10000	15000	10000
General specifications															
Maximum platform size		mm	300 × 300				450 × 450				600 × 600				
Nominal sensitivity Maximum capacity 1 kg Maximum capacities 3 kg...200 kg	C_n	mV/V	1.8 +0.27 -0.18 (Option 6: A1 = 1.8 mV/V±0.1 %) 2.0±0.2 (Option 6: A = 2mV/V±0.1 %)												
Zero signal		mV/V	0±0.1												
Temperature coefficient of sensitivity ²⁾ Temperature range: +20 °C ... +40 °C -10 °C ... +20 °C	TC_S	% of $C_n/10\text{ K}$	± 0.0170 ± 0.0110												
Non-linearity ²⁾	d_{lin}	% of C_n	± 0.0166												
Relative reversibility error ²⁾	d_{hy}		± 0.0166												
Minimum dead load output return	MDLOR		± 0.0166												
Off-center load error ³⁾ , as per OIML R76			± 0.0233												
Input resistance	R_{LC}	Ω	300...500												
Output resistance	R_0		300...500 (Option 6: A = 410 Ω ±0.2 Ω)												
Reference voltage	U_{ref}	V	5												
Nominal (rated) range of the excitation voltage	B_U		1 ... 12												
Max. excitation voltage			15												
Insulation resistance at 100 V _{DC}	R_{is}	G Ω	>2												
Nominal (rated) range of the ambient temperature	B_T	°C	-10 ... +40												
Operating temperature range	B_{tu}		-10 ... +50												
Storage temperature range	B_{tl}		-25 ... +70												
Limit load	E_L	% of E_{max}	150												
Limit lateral loading, static	E_{lq}		300												
Service load at max. 100 mm eccentricity	E_U	% of E_{max}	150												
Breaking load at 20 mm eccentricity	E_d		300												
Relative permissible oscillation stress at max. 20 mm eccentricity	F_{srel}		70												
Rated displacement at E_{max} , approx.	s_{nom}	mm	<0.5	<0.3				<0.25							
Weight, approx.	m	kg	0.45												
Degree of protection ⁴⁾			IP67												
Material Measuring body Application protection Cable sheath			Aluminum Silicone rubber PVC												

1) Max. eccentric loading as per OIML R76.

2) If the values for non-linearity (d_{lin}), relative reversibility error (d_{hy}) and temperature coefficient of sensitivity (TC_S) are added together, they are within the cumulated error limit specified in OIML R60.

3) As per OIML R76

4) As per EN 60 529 (IEC 529)

SPECIFICATIONS (CONTINUED)

Type			SP4M...												
Accuracy class as per OIML R60			C6 Multi Range (MR)												
Number of load cell verification intervals	n_{LC}		6000												
Maximum capacity ¹⁾	E_{max}	kg	7	10	15	18	20	30	36	50	75	100	150	200	
Minimum load cell verification interval	v_{min}	g	0.5	0.5	1	1	1	2	2	2	5	5	10	10	
Temperature coefficient of zero signal	TC_0	% of $C_n/10$ K	± 0.0084	± 0.0070	± 0.0084	± 0.0070	± 0.0070	± 0.0093	± 0.0070	± 0.0056	± 0.0084	± 0.0070	± 0.0084	± 0.0070	
Ratio of minimum verification interval	Y		14000	20000	15000	18000	20000	15000	18000	25000	15000	20000	15000	20000	
Accuracy class as per NTEP			III S												
Number of load cell verification intervals	n_{LC}		5000												
Maximum capacity	E_{max}	kg	7	10	15	-	20	-	36	50	75	100	150	200	
Minimum load cell verification interval	v_{min}	g	0.42	0.61	0.91	-	1.21	-	2.18	3.03	4.55	6.06	9.09	12.12	
Ratio of minimum verification interval	Y		16667	16393	16484		16529		16514	16502	16484	16502	16502	16502	
General specifications															
Max. platform size		mm	300 x 300			450 x 450					600 x 600				
Nominal sensitivity	C_n	mV/V	2.0 \pm 0.2			1.8 \pm 0.18	2.0 \pm 0.2		2.4 \pm 0.2	2 \pm 0.2	2 \pm 0.2	2 \pm 0.2	2 \pm 0.2	2 \pm 0.2	
Zero signal			0 \pm 0.10												
Temperature coefficient of sensitivity ²⁾ Temperature range: +20 ... +40 °C -10 ... +20 °C	TC_S	% of $C_n/10$ K	± 0.0087 ± 0.0058												
Relative reversibility error ²⁾	d_{hy}		± 0.0083												
Non-linearity ²⁾	d_{lin}		± 0.0083												
Minimum dead load output return	MDLOR	% of C_n	± 0.0083												
Off-center load error ³⁾			± 0.0116												

1) Max. eccentric loading as per OIML R76.
 2) The values for non-linearity (d_{lin}), relative reversibility error (d_{hy}) and temperature coefficient of sensitivity (TC_S) are recommended values. If these values are added together, they are within the cumulated error limit specified in OIML R60.
 3) As per OIML R76

For further specifications, see Table SP4M..., Accuracy class C3 Multi Range (MR) (page 2)

CABLE ASSIGNMENT

6-wire cable connection, 6 x 0.14 mm²/AWG 26 (available cable lengths: 1.5 m; 3 m; 6 m; 12 m)

Schematic diagram of a TE connector (TE 3-640442-6), 6-pin
Connector only with Option 4: = N (no explosion protection)

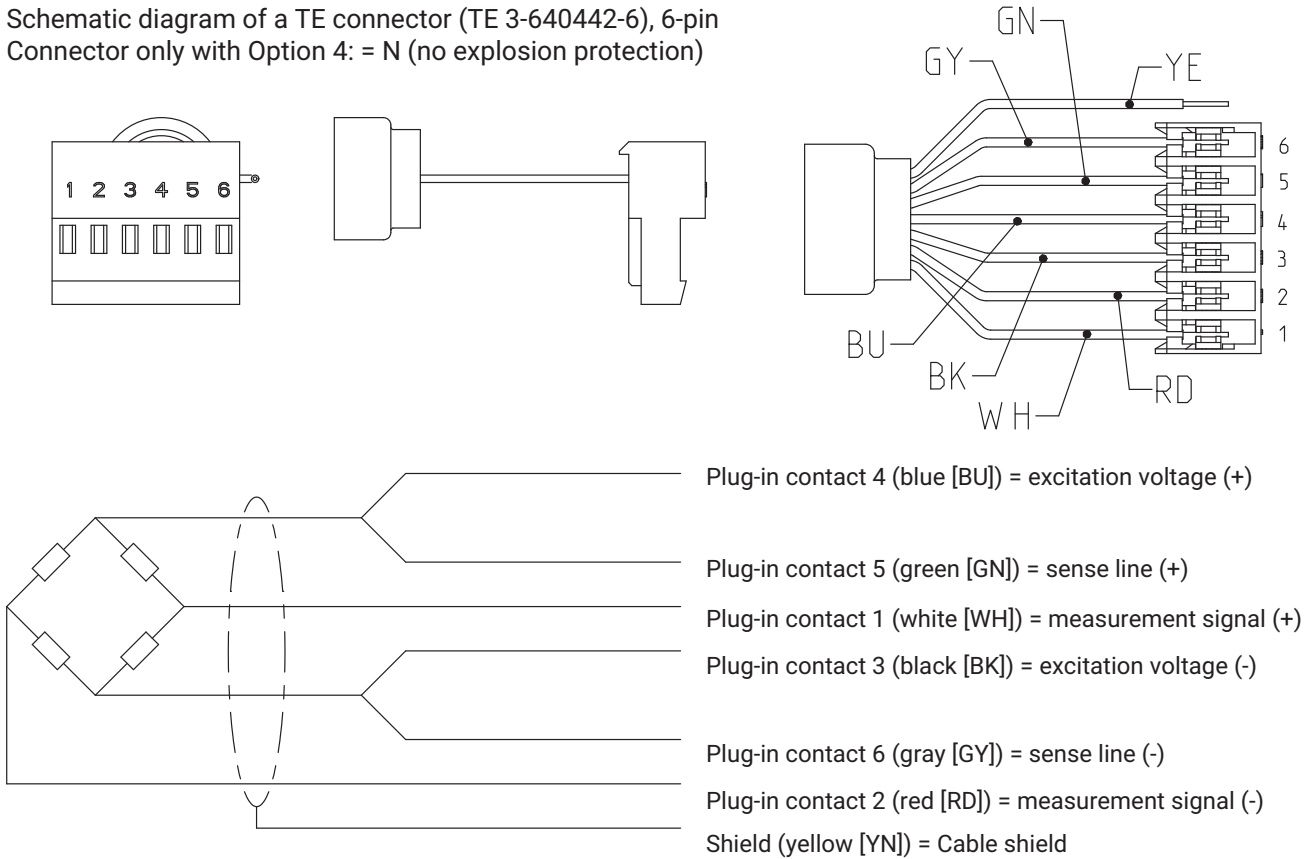

MOUNTING AND LOAD APPLICATION

The load cells are firmly clamped at the mounting holes, the load is applied at the other end. The recommended screws and tightening torques can be found in the table below:

Maximum capacities	Thread	Min. property class	Tightening torque ¹⁾
1...36 kg	M6	8.8	6 N·m
50...200 kg	M6	10.9	14 N·m

¹⁾ Recommended value for the specified property class. Please comply with the screw manufacturer's instructions with regard to screw dimensions.

Load must not be applied to the side where the cable connection is located, as this would cause a force shunt.

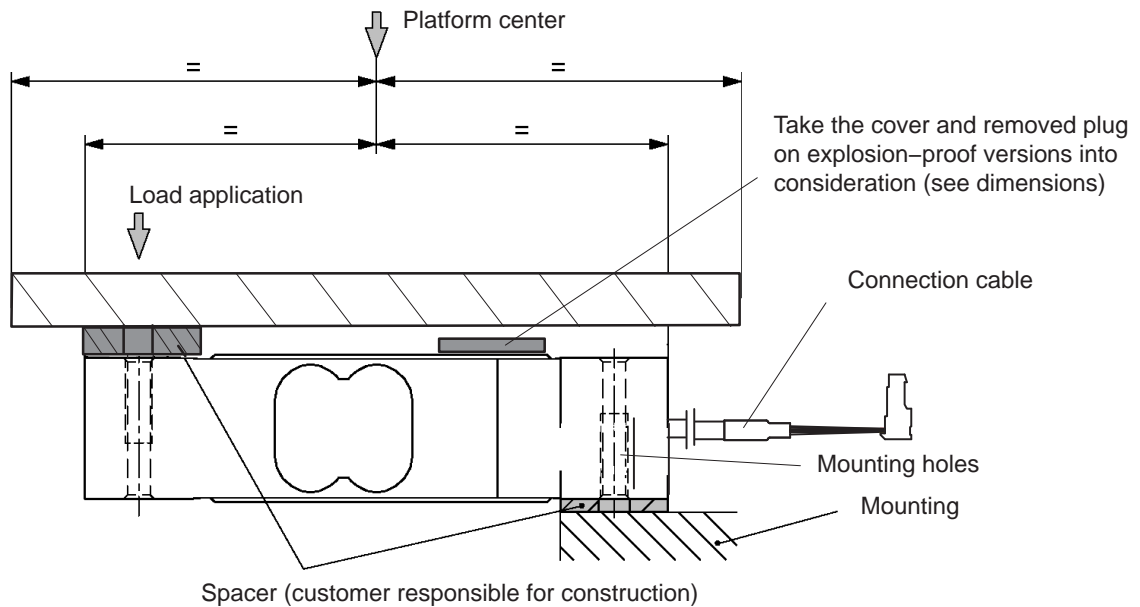

PRODUCT NUMBERS (OVERVIEW)

SP4M... (aluminum)

Type	SP4M	
Accuracy class	C3-MR (OIML) (Multi Range)	C6-MR (OIML) (Multi Range)
Comments	Cable length 3 m (6-wire)	Cable length 3 m (6-wire)

Maximum capacity [kg]	Ordering number	Ordering number
1	1-SP4MC3MR/1KG-1	-
3	1-SP4MC3MR/3KG-1	-
5	1-SP4MC3MR/5KG-1	-
7	1-SP4MC3MR/7KG-1	1-SP4MC6MR/7KG-1
10	1-SP4MC3MR/10KG-1	1-SP4MC6MR/10KG-1
15	1-SP4MC3MR/15KG-1	1-SP4MC6MR/15KG-1
18	-	1-SP4MC6MR/18KG-1
20	1-SP4MC3MR/20KG-1	1-SP4MC6MR/20KG-1
30	1-SP4MC3MR/30KG-1	-
36	-	1-SP4MC6MR/36KG-1
50	1-SP4MC3MR/50KG-1	1-SP4MC6MR/50KG-1
75	1-SP4MC3MR/75KG-1	1-SP4MC6MR/75KG-1
100	1-SP4MC3MR/100KG-1	1-SP4MC6MR/100KG-1
150	1-SP4MC3MR/150KG-1	1-SP4MC6MR/150KG-1
200	1-SP4MC3MR/200KG-1	1-SP4MC6MR/200KG-1

SP4M... (aluminum), optional versions

K-SP4M				
1	Code	Option 1: Mechanical design		
	N	-		
2	Code	Option 2: Accuracy class		
	C3MR	C3-MR (OIML) (Multi Range)		
	C6MR	C6-MR (OIML) (Multi Range) [only with Option 3: = 15 / 20 / 30 / 50, Option 5: = 6, Option 6: = N]		
3	Code	Option 3: Nominal load	Code	Option 3: Nominal load
	1	1 kg	30	30 kg
	3	3 kg	50	50 kg
	5	5 kg	75	75 kg
	7	7 kg	100	100 kg
	10	10 kg	150	150 kg
	15	15 kg	200	200 kg
	20	20 kg		
4	Code	Option 4: Explosion protection		
	N	No explosion protection		
	A11/21	ATEX+IECEX+FM Zone 1/21, intrinsically safe; ATEX/IECEX: II 2G Ex ia IIC T6/T4 Gb + II 2D Ex ia IIIC T125°C Db; FM(US/CA): Class I Zone 1 AEx/Ex ia IIC T4 Gb + Zone 21 AEx/Ex ia IIIC T125°C Db; FM(US): Class I, II, III Division 1, Groups A, B, C, D, E, F, G T4		
	A12/22	ATEX+IECEX Zone 2/22, not intrinsically safe; ATEX/IECEX: II 3G Ex ec IIC T6/T4 Gc + II 3D Ex tc IIIC T125°C Dc		
5	Code	Option 5: Cable length		
	1.5	1.5 m		
	3	3 m		
	6	6 m		
	12	12 m		
6	Code	Option 6: Other		
	N	Without		
	A	2 mV/V ±0.1% / 410 Ω ± 0.2 Ω (adjusted output, suitable for parallel connection)		[not with option 3 = 1]
	A1	1.8 mV/V ±0.1% / 410 Ω ± 0.2 Ω (adjusted output, suitable for parallel connection)		[only with option 3 = 1]

K-SP4M -

N

 -

--	--	--	--

 -

--	--	--	--

 -

--	--	--	--	--	--	--	--

 -

--	--	--

 -

--	--

1 2 3 4 5 6

Not all codes can be combined with one another. Take note of the conditions in square brackets!

LCMC - LOAD CELL MEASURING CHAIN

A wide range of famous load cells combined with a choice of excellent measuring electronics makes your tailored Load Cell Measuring Chain.

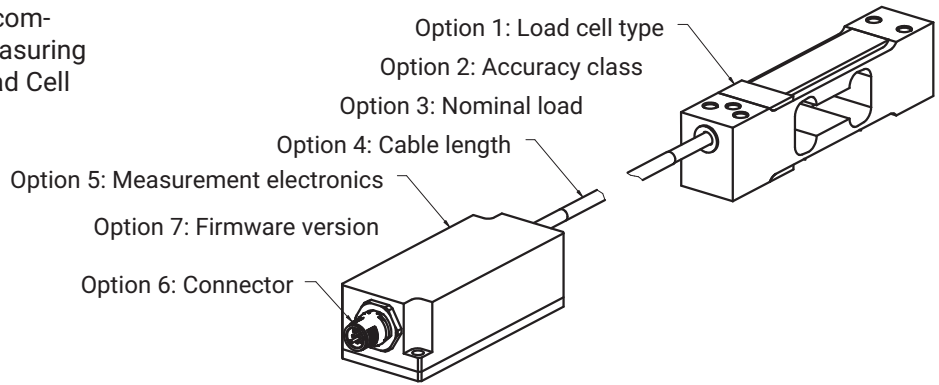

K-LCMC-SP4M ordering options

K-LCMC				
1	Code	Option 1: Load cell type		
	SP4M	SP4M		
2	Code	Option 2: Accuracy class		
	MR	C3 MR (OIML)		
3	Code	Option 3: Nominal load	Code	Option 3: Nominal load
	1K00	1 kg	30K0	30 kg
	3K00	3 kg	50K0	50 kg
	5K00	5 kg	75K0	75 kg
	7K00	7 kg	100K	100 kg
	10K0	10 kg	150K	150 kg
	15K0	15 kg	200K	200 kg
	20K0	20 kg		
4	Code	Option 4: Cable length		
	0M3	0.3 m		
	0M5	0.5 m		
	1M0	1.0 m		
	3M0	3.0 m		
5	Code	Option 5: Measurement electronics		
	105C	CAN (200 S/s)		
	105R	RS485 (200 S/s) 2-wire		
	112C	CAN (1,200 S/s)		
	112R	RS485 (1,200 S/s) 4-wire		
	RM42	Analog 4 ... 20 mA		
	RM43	Analog 0 .. 10 V		
RMIO	IO-link			
6	Code	Option 6: Connector		
	M12A8	M12 A-coded, male, 8-pin		
	M12A4	M12 A-coded, male, 4-pin		
7	Code	Option 7: Firmware version		
	N	NA		
	01	WTIO 1.03.00		

K-LCMC -

S	P	4	M
---	---	---	---

 -

M	R
---	---

 -

--	--	--	--

 -

--	--	--	--

 -

--	--	--	--	--	--

 -

--	--	--	--	--	--	--	--

 -

--	--

1 2 3 4 5 6 7

Hottinger Brüel & Kjaer GmbH

Im Tiefen See 45 · 64293 Darmstadt · Germany
Tel. +49 6151 803-0 · Fax +49 6151 803-9100
www.hbkworld.com · info@hbkworl.com

Subject to modifications. All product descriptions are for general information only. They are not to be understood as a guarantee of quality or durability.