

INVESTIGATION OF THE INFLUENCE OF TRANSDUCER ELECTRONIC DATA SHEETS (TEDS) ON CALIBRATION RESULTS

Jochen Schneider¹, Lioba Stenner², Georg Wegener³

¹ HBM, Darmstadt, Germany, jochen.schneider@hbm.com

² HBM, Darmstadt, Germany, lioba.stenner@hbm.com

³ HBM, Darmstadt, Germany, georg.wegener@hbm.com

Abstract: The international standard IEEE 1451.4 [1] is the basis for transducer electronic data sheets (TEDS), where information related to the transducer like serial number or nominal sensitivity is stored into a chip inside the transducer. For bridge type sensors, with a novel circuit (patent pending [2]) it is possible to read the TEDS information for 6-wire bridge sensors without additional wires by using the sense lines. The paper shows the investigations of the influence of TEDS on measurement results. Voltage ratio calibrations with TEDS between measuring amplifier and calibration unit had been carried out at different carrier frequencies. Verification measurements with the TEDS chip built into a force transducer checked for the technical specifications e.g. temperature behavior of the nominal sensitivity. Additional investigations focus on different linearization methods checked with force and voltage ratio calibrations. With force calibration according to ISO 376 a 3rd degree polynomial equation is calculated from the calibration results. With a new kind of amplifier it is possible to store the coefficients of this polynomial equation and make an online calculation. The results of the measurements when using TEDS to store the coefficients and read into the amplifier are presented.

Keywords: TEDS - Transducer Electronic Data Sheet, calibration, measuring amplifier, polynomial equation, force transducer.

1. INTRODUCTION

Transducer electronic data sheets (TEDS) help the user to set up their amplifier very quickly. To achieve this, all information about the transducer is stored into an electronic chip integrated into the transducer itself. The information is imported by the measuring amplifier and used for its adjustment. The international standard IEEE 1451.4 [1] defines the method with its unique serial number, the data format, the data protocol and the most essential data blocks (templates). Not completely defined is the wiring. Most solutions add the TEDS chip with two additional wires, but needing no additional wires is advantageous for most applications. In this case the chip can be added into an existing transducer without changing connectors. Especially for bridge type sensors, with a novel circuit [2] it is possible

to read the TEDS information for 6-wire bridge sensors using the sense lines, therefore no additional wires are necessary. The principle of this circuit is shown in Figure 1. The TEDS chip and the control circuit are added between the sense line and the excitation line.

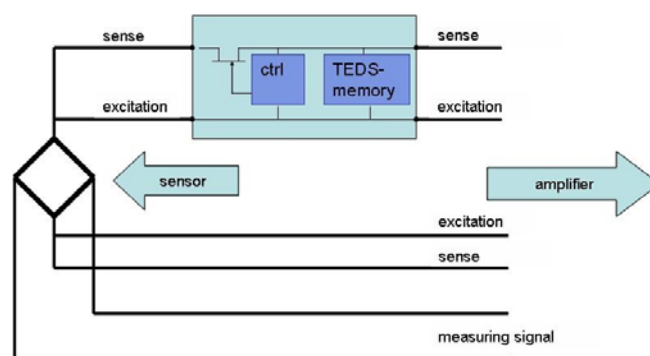

Fig. 1. Layout circuit with TEDS-chip for 6-wire bridge sensors

The amplifier will switch between the measuring mode and the TEDS information mode. This is only done when setting up the amplifier, during the measuring mode the TEDS circuit is passive. Although the principle of the circuitry keeps the impact on the measuring signal low, there are electronic components which have been added between the transducer and the measuring amplifier and their influence has to be checked.

In industries most measuring amplifiers may be adjusted with a two point linearization, a straight line between the zero point and the nominal physical value with its corresponding sensitivity. The linearity error for this method is quite high. A polynomial of higher order describes the ratio between the electrical and physical value much better. With a new kind of measuring amplifier it is now possible to store the coefficients of a 3rd-order polynomial equation into the memory of the amplifier and to use them for an online calculation.

Information about a higher order polynomial for linearization of a transducer can be stored into the TEDS chip. It is defined in the IEEE 1451.4 standard in a template named calibration curve. A multi-segment polynomial calibration curve is specified to describe the electrical-to-

physical transfer function of the transducer. The principle of the function is shown in figure 2.

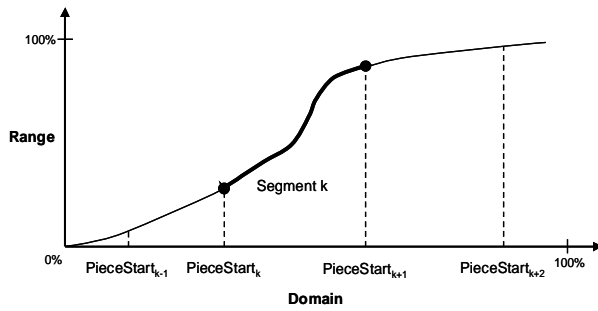

Fig. 2. Definition of the calibration curve by the IEEE 1451.4 standard [1]

The coefficients of the 3rd order polynomial equation given in calibration certificates for force transducers according to ISO 376 or torque calibration certificates according to DIN 51309, resp. EA 10-14 are defined different to the IEEE 1451.4 standard and can not be typed unchanged into the TEDS calibration template. A conversion is necessary which has to be verified.

2. VOLTAGE RATIO CALIBRATION

For investigating the influence of the TEDS chip on voltage ratio calibrations measurements with and without the additional TEDS circuit have been carried out.

2.1. Description of the setup for voltage ratio calibration

A computer controlled calibration unit (model K148) simulating strain-gauge full-bridge sensors has been connected to measuring amplifiers of one system (MGCplus) with different carrier frequencies (225 Hz, 600 Hz, 4.8 kHz) and DC. The setup can be seen in figure 3. Seven points in positive and negative direction from 0 mV/V to 2 mV/V have been measured. The filter frequency has been set to 0.5 Hz.



Fig. 3. Setup of the voltage ratio calibration with MGCplus measuring amplifier and computer controlled calibration unit K148

After the first calibration without TEDS an additional adaptor cable with the TEDS circuit inside has been connected between the calibration unit and the measuring

amplifier. Just after that the same measurements have been carried out again.

2.2. Results of the voltage ratio calibration

For the evaluation the measured values without and with TEDS have been compared.

Figure 4 shows the absolute deviation between the first measurement without and the second measurement with TEDS. Only at the carrier frequency 4.8 kHz a very small deviation of 0.0003 mV/V can be seen. But this is only a constant shift which will be compensated when setting the amplifier to zero or when calibrating the transducer with an already mounted TEDS. And compared to the accuracy of the amplifier with 0.03% this effect is negligible.

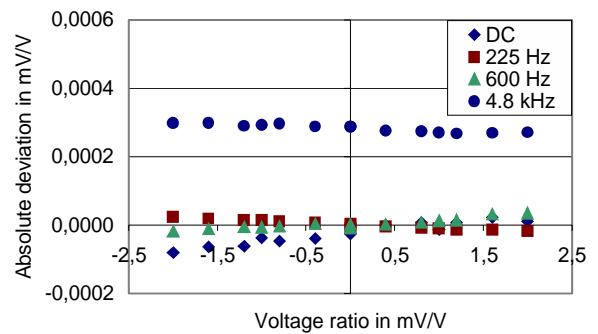

Fig. 4. Absolute deviation for different carrier frequencies between voltage ratio calibration with and without TEDS

There has been no change in the linearity with TEDS compared to the calibration without TEDS, respectively the linearity deviation has always been much better than the allowed and the differences are within the measurement uncertainty of the calibration and are listed in table 1.

Table 1. Linearity deviation for different carrier frequencies with and without TEDS

Amplifier type	Allowed linearity deviation in %	Maximum linearity deviation in %	
		Without TEDS	With TEDS
DC	0.03	-0.0002	+0.0004
225 Hz	0.002	-0.0002	-0.0004
600 Hz	0.02	+0.004	-0.001
4.8 kHz	0.02	-0.0009	-0.0012

3. VERIFICATION MEASUREMENTS FOR TEDS IMPLEMENTED INTO FORCE TRANSDUCERS

When adding TEDS into transducers several measurements must prove that there will be no influence on the technical specifications of the transducer. For these tests the TEDS chip has been implemented into a force transducer with a nominal sensitivity of 200 N. The measuring body was made of aluminum and based on the bending beam principle.

3.1. EMC Conformity

An important aspect for industrial measurements is the EMC conformity. This has been approved by HBM's EMC-

laboratory which is accredited according to ISO 17025. The irradiation measurements have been carried out according to EN 61236.

The force transducer passed all tests, TEDS has no impact on the EMC conformity.

3.2. Temperature behavior

Another technical specification the TEDS chip may have impact on is the effect of temperature on the sensitivity. The force transducer with TEDS had to run several temperature cycles. The worst TK_C is listed in table 2, compared with the allowed TK_C of this force transducer type and compared with a transducer of the same type without TEDS.

There is no importance on the TK_C by TEDS, the effect per 10K is still within the normal distribution of this force transducer type and far away from the permissible value.

Table 2. Effect of temperature on sensitivity with and without TEDS compared with the allowed specification

Force Transducer	Allowed TK_C Effect / 10 K	Measured TK_C Effect / 10 K
Without TEDS	0.015	0.0033
With TEDS	0.015	0.0048

4. LINEARIZATION METHODS

4.1. Test description

Two different force transducer types have been chosen for force calibrations according to ISO 376. One type with a higher nonlinearity (membrane measuring body, model C2/1000N) and a second type (parallel bending beam, model TOP-Z30A/2kN) with a very good linearity [3]. For the measurements these transducers have been connected to an amplifier with 225 Hz carrier frequency (ML38B of the MGCplus measuring amplifier system), the principle of the setup is shown in figure 5.



Fig. 5. Force transducer Z30A connected to the measuring amplifier of the MGCplus system

Polynomial coefficients up to 3rd order can be stored into the amplifier and it has the functionality to write and read the TEDS chip with the novel circuit for 6-wire transducers without any additional wire which is described in section 1. When storing and activating the coefficients an online calculation shows the linearized physical values in the display.

For the measuring chain with suitable force introduction parts force calibrations according to ISO 376 have been

carried out in 8 steps at 10%, 20%, 30%, 40%, 50%, 60%, 80% and 100% of the nominal force. The force calibration machine used has been HBM's deadweight calibration machine accredited in the DKD (DKD – German Calibration Service) with a best possible relative measurement uncertainty of 0.005% in compression and 0.008% in tension.

For the first evaluation the measured values have been taken into account in the electronic unit mV/V, without any linearization or additional adjustment of the amplifier. This gives the unchanged behavior of the force transducers. From these points the interpolation equations of 1st order (two-point linearization) and 3rd order can be calculated using the method of least squares. A 1st order interpolation will be calculated with the following equation:

$$Y_{ph} = A_0 + A_1 Y_{el} \quad (1)$$

For the 3rd order interpolation the following equation is used:

$$Y_{ph} = A_0 + A_1 Y_{el} + A_2 Y_{el}^2 + A_3 Y_{el}^3 \quad (2)$$

The second calibration has been carried out with identical calibration procedure but this time with the 3rd order coefficients of the first calibration stored into TEDS and activated in the amplifier. Just one segment of the multi-segment polynomial calibration curve of TEDS is used, because of the amplifiers features and the indication in the calibration certificate. The display showed the converted physical values in Newton.

For a last verification again a voltage calibration of the amplifier ML38B has been carried out. The setup has been similar to the one described in section 2.1. But this time the coefficients of the 3rd order polynomial from the force calibrations have been stored into the TEDS chip, then read by the amplifier, used for the setup and calculation of the displayed values in Newton.

4.2. Results for the linearization methods

The difference for the relative interpolation error between the two point-point linearization and the linearization equation 3rd order is shown in figure 6 for the force transducer C2. The 3rd order equation has a significantly better behavior.

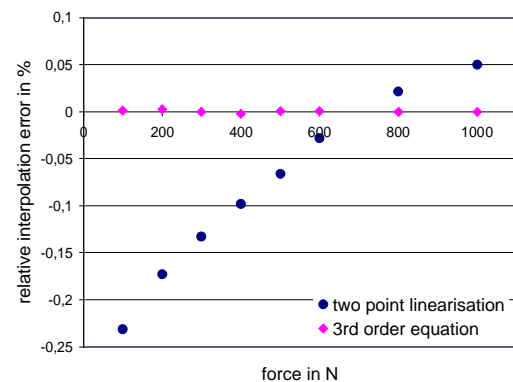

Fig. 6. Difference of the relative interpolation error with linear equation and with polynomial equation for force transducer C2

For checking the influence of the online calculation with the polynomial coefficients the relative interpolation error without (first calibration) and with activated polynomial coefficients (second calibration) is compared.

In figure 7 the results for the relative interpolation error according to ISO 376 of the two calibrations for the C2 force transducer are displayed. The calibration with the polynom results in a behaviour which is up to 2.5 times better.

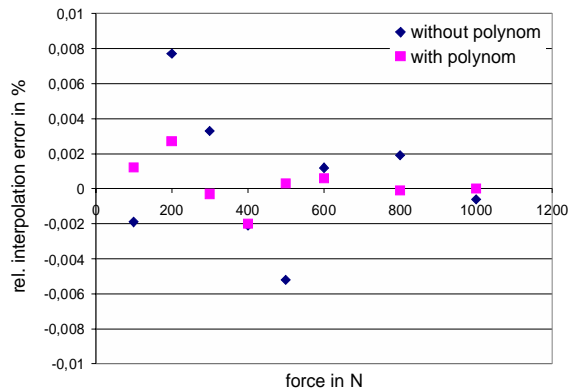

Fig. 7. Difference of the relative interpolation error without and with polynomial coefficients activated in the amplifier for the force transducer C2

Figure 8 shows the results for the relative interpolation error of the TOP-Z30A force transducer. This force transducer type already has an excellent linearity with the calibration in electrical units. In this case the comparison of the two calibrations gives the safety that the coefficients are not changing the behavior of an excellent transducer into worse.

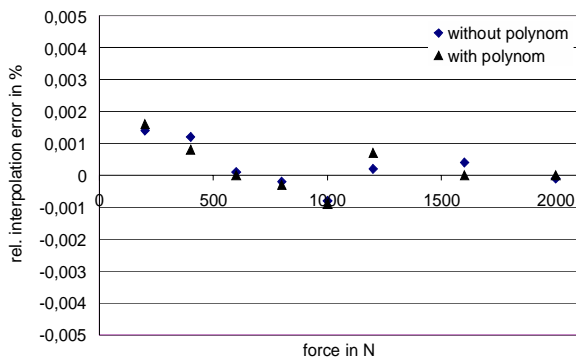

Fig. 8. Difference of the relative interpolation error without and with polynomial coefficients activated in the amplifier for the force transducer TOP-Z30A

For the verification of the linearization method, the conversion of the coefficients into the TEDS definition and reloading and recalculating this into the amplifier, not only the interpolation error is relevant, checking the absolute values is important too. For that the coefficients for the 3rd order polynomial have been taken from the first calibration to calculate the theoretical values in Newton. These theoretical values are compared with the measured values obtained with the second calibration. The accuracy of this comparison method is limited by the measurement

uncertainty of the force calibration. A much better measurement uncertainty will be reached with a voltage ratio calibration. For that reason the results of the voltage ratio calibration with activated coefficients are added to the graphs of figure 9 and 10 where the absolute deviation between the theoretical values and the measured values are shown.

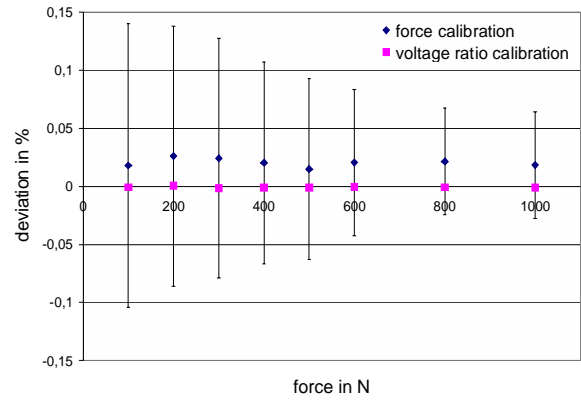

Fig. 9. Deviation of the absolute value theoretical calculate and obtained from force and from voltage ratio calibration for the coefficients of force transducer C2

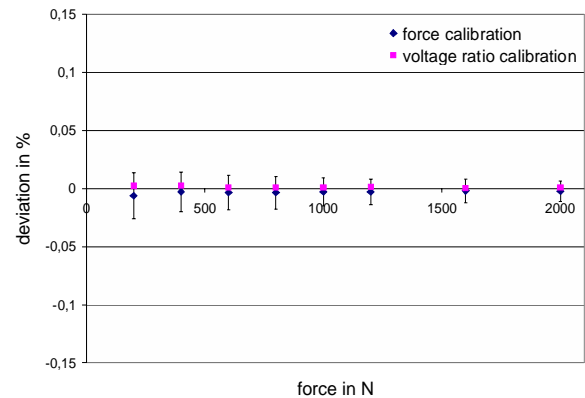

Fig. 10. Deviation of the absolute value theoretical calculate and obtained from force and from voltage ratio calibration for the coefficients of force transducer TOP-Z30A

For the force calibration the absolute deviation is much smaller than the expanded measurement uncertainty calculated according to EA 10/04 which is shown in the graphs with the error bars. The voltage ratio calibration shows a much smaller difference between the calculated and the measured values. Thus it is expected that the main deviation is coming from the behavior of the force transducer, the conversion inside the measuring amplifier has a negligible effect on the calibration result.

5. CONCLUSION

The influence of the TEDS chip with the novel circuit, which eliminates the need of extra wires in bridge type sensors, on the measuring accuracy at different carrier frequencies is negligible. Such a TEDS chip holds the calibration information of a transducer, which may be best described by a nonlinear relationship. Verification

measurements have shown that this TEDS circuit has no influence on the technical specifications of a transducer and thus may be added into the measuring body without any disadvantages.

It is possible to store the coefficients of a 3rd order polynomial into a measuring amplifier and to do a real time calculation for the displayed physical result. Measurements have shown a significantly better behavior compared to a two point linearization. With the measuring amplifiers available at the moment it is not yet possible to use the full capability of the TEDS multi segment calibration curve. Maybe new amplifier generations will have this feature and thus help to increase the accuracy for calibrations [4]. This feature will be more important when using transducers with a poor linearity. For transducers already showing a small interpolation error the additional minimizing effect is very low, it can not be differentiated between the error of the calibration machine and the portion of the transducer.

The main advantage of TEDS inside the transducer is that the polynomial coefficients are dedicated to a single transducer. When the transducer is connected to an amplifier it is not necessary to do a manual setup (e.g. enter the polynomial coefficients), with TEDS it is done automatically. This gives a higher safety for the set up of the amplifier and thus for the measurements.

REFERENCES

- [1] IEEE 1451.4, A Smart Transducer Interface for Sensors and Actuators – Mixed-Mode Communication Protocols and Transducer Electronic Data Sheet (TEDS) Format, 2004
- [2] Transducer comprising connected data memory, pending patent application, WO 03/001155 A2, 2003
- [3] [4] L. Stenner, J. Andrae, J. Mack, R. Kümme “Experience with a New Class of Force Transfer Standards”, Proceedings of the Joint international conference IMEKO TC3/TC5/TC20, pp 403-409, Celle, September 2002
- [4] B. Katz “A New Way to Minimize Uncertainty in Calibration Process of Force Testing Machines”, Proceedings of the Joint international conference IMEKO TC3/TC5/TC20, pp 571-575, Celle, September 2002