

## Clip Electronic

Amplifier for installation onto mounting rails

## Clip IG

Industrial amplifier in cast housing





<b>Contents</b>	<b>Page</b>
<b>Safety instructions</b> .....	<b>4</b>
<b>1 Application</b> .....	<b>7</b>
<b>2 Mounting / Dismounting</b> .....	<b>8</b>
<b>3 Connection</b> .....	<b>9</b>
3.1 Measuring amplifiers AE101, AE301, AE501 .....	10
3.2 GR201, EM201, EM201K2, TS101 additional units .....	12
3.3 NT101A, NT102A Power supply .....	14
<b>4 Setup</b> .....	<b>15</b>
4.1 AE101 Measuring amplifiers .....	15
4.2 AE301 Measuring amplifier .....	18
4.3 AE501 Measuring amplifier .....	22
4.4 GR201 Double limit-value switch .....	25
4.5 EM201 / EM201K2 Output stage .....	28
<b>5 TS101 Automatic tare and store unit</b> .....	<b>30</b>
5.1 General .....	30
5.2 Function .....	30
5.2.1 Taring .....	30
5.2.2 Store unit .....	31
5.3 Connection .....	33
5.3.1 Voltage supply .....	34
5.3.2 Inputs / Outputs .....	34
5.3.3 Control inputs / Control output .....	34
5.4 Adjustment .....	36
5.4.1 Factory setup .....	36
5.4.2 Tare unit adjustment .....	36
5.4.3 Store unit adjustment .....	38
5.5 Zero-point balance .....	40
5.6 Component position diagram .....	41
<b>6 Safety barriers</b> .....	<b>42</b>
<b>7 CLIP IG</b> .....	<b>42</b>
<b>8 Dimensions</b> .....	<b>43</b>

## Safety instructions

The NT101A and NT102A Power Supplies Conform to Protection Class I. The other Clip components correspond to Protection Class III (Symbol )

when they are operated with safety extra-low voltage (SELV circuits).

In order to ensure sufficient immunity from disturbance only use Greenline screening (see HBM's special publication "Greenline shielding design, EMC-compliant measuring cable")

### Appropriate use

The Clip Electronic with the connected transducers may be used for measurement and directly related control and regulation tasks, only. Any other use is not appropriate.

To ensure safe operation, the Clip Electronic may only be used according to the specifications given in this manual. When using the transducer, the legal and safety regulations for the respective application must also be observed. The same applies if accessories are used.

### General dangers in the case of non-observance of the safety instructions

The Clip Electronic complies with the state of the art and is operationally reliable. If the device is used and operated inappropriately by untrained personnel, residual dangers might develop.

Any person charged with device installation, operation, maintenance or repair must in any case have read and understood the operating manual and the safety instructions, in particular.

### Conditions on site

Protect the device from moisture or atmospheric influences such as rain, snow, etc.

### Maintenance and cleaning

The Clip Electronic are maintenance-free. Please note the following points when cleaning the housing:

- Remove the mains plug from the socket before cleaning.
- Clean the housing with a soft, slightly damp (not wet!) cloth. **Never** use solvents, since they may damage the labelling on the front panel.
- When cleaning, please ensure that no liquid finds its way into the device or onto the contacts.

## Residual dangers

The Clip Electronic scope of performance and supply covers part of the measuring-technology, only. The plant designer/constructor/operator must in addition design, realize and take responsibility for the measuring-system's safety such that potential residual dangers are minimized. The respective regulations must in any case be observed. Residual dangers regarding the measuring system must be specified explicitly.

If there is any risk of remaining dangers when working with the, it is pointed out in this introduction by means of the following symbols:



**DANGER**

*Meaning:*

**Maximum danger level**

Warns of an **imminently** dangerous situation in which failure to comply with safety requirements **will** result in death or serious physical injury.



**WARNING**

*Meaning:*

**Dangerous situation**

Warns of a **potentially** dangerous situation in which failure to comply with safety requirements **can** result in death or serious physical injury.



**CAUTION**

*Meaning:*

**Potentially dangerous situation**

Warns of a **potentially** dangerous situation in which failure to comply with safety requirements **could** result in damage to property or some form of physical injury.

Symbols for using advices and helpful information:



Symbol:

**NOTE**

Means that important information about the product or its handling is being given.



Symbol:

*Meaning:* **CE mark**

The CE mark enables the manufacturer to guarantee that the product complies with the requirements of the relevant EC directives (the declaration of conformity is available at <http://www.hbm.com/HBMdoc>).

### **Safe operation**

Do only quit error messages if the reason for the error has been eliminated and there is no more danger.

### **Reconstruction and modifications**

HBM's express consent is required for modifications regarding the Clip Electronic construction and safety. HBM does not take responsibility for damage resulting from unauthorized modifications.

In particular, repair and soldering works on the boards are prohibited. If complete componentry is replaced use original HBM components, only.

### **Qualified personnel**

The device may be used by qualified personnel, only; the technical data and the special safety regulations must in any case be observed. When using the device, the legal and safety regulations for the respective application must also be observed. The same applies if accessories are used.

Qualified personnel means: personnel familiar with the installation, mounting, start-up and operation of the product, and trained according to their job.

Maintenance and repair work on an open device with the power on should only be undertaken by trained personnel who are aware of the above-mentioned dangers.

## 1 Application

The measuring amplifiers are suitable for the measurement of mechanical quantities such as force, weight, torque, pressure, displacement, strain and acceleration. Appropriate transducers complying with the international standards can be connected to the measuring amplifiers.

Transducers can be operated in potentially explosive areas, if safety barriers are used.

The individual CLIP components can be arranged as desired and are wired by terminals. Switches and potentiometers for adjustment have been provided on the circuit boards. The accuracy class is 0.1.

The following units are available:

- AE101 (DC), AE301/301S6/301S7 (600 Hz CF), AE501 (4.8 kHz CF), Measuring amplifier
- GR201 Double limit-value switch
- EM201, EM201K2 Output-stage modules with current output
- NT101A, NT102A Power supply units
- TS101 Automatic Tare and Store Unit

## 2 Mounting / Dismounting

The housings are installed onto mounting rails to DIN EN 50 022; they are hooked onto the upper edge and snapped into the spring plate on the lower edge.

For dismounting, use a screwdriver to push down the spring plate and unhook the housing.

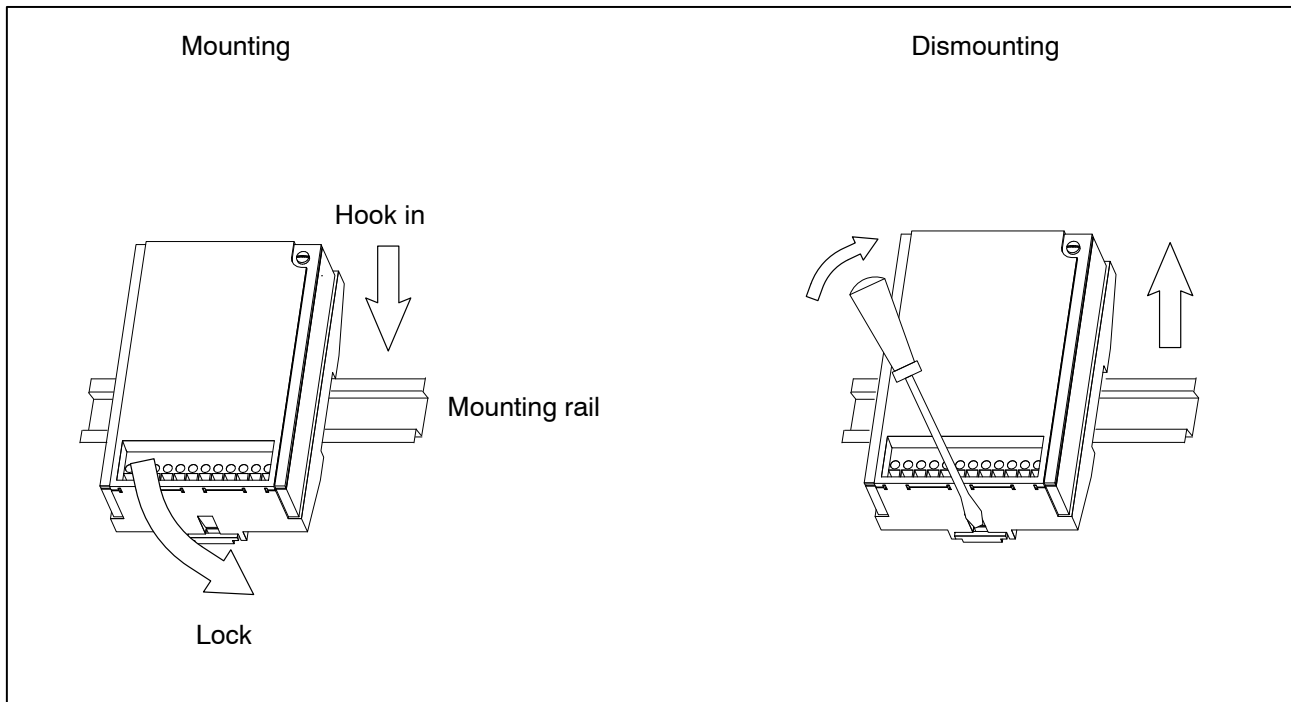

**Fig. 2.1:** Mounting / Dismounting



### 3 Connection

Use the 12-pin terminal strip to connect the transducers, to wire the modules with each other and to connect the voltage supply. Individual wires can be clamped in a range of 0.13 mm<sup>2</sup> ... 1.5 mm<sup>2</sup>. If two conductor lines are to be connected to one terminal, e.g. with internal and external connections, the conductor cross-sections must be matched accordingly. End sleeves (without plastics hoop, length: 10 mm) should be used to connect the cores to the terminals. Cores with or without end sleeves must not be tin-plated. When connecting the lines, measures should be taken to prevent electrostatic discharge.

The subsequent figures give the respective connection diagrams that are printed onto the housing cover.



#### NOTE

**The Clip modules have been designed for installation in closed metallic housings (e. g. control cabinet); they can also be operated without any additional housings.**

**The transducer connection lines and the analog signal lines (inputs and outputs) have to be screened.**

**At the control cabinet, the screening must lie on a screen rail.**

**Supply lines and lines connected to the GR201 relay contacts must be screened if the cable length exceeds 30 m or if the cables are routed outside closed buildings.**



#### NOTE

**Only after tightening the clamping screws (ensure good contact) will the output signal be available on the terminals.**

### 3.1 Measuring amplifiers AE101, AE301, AE501

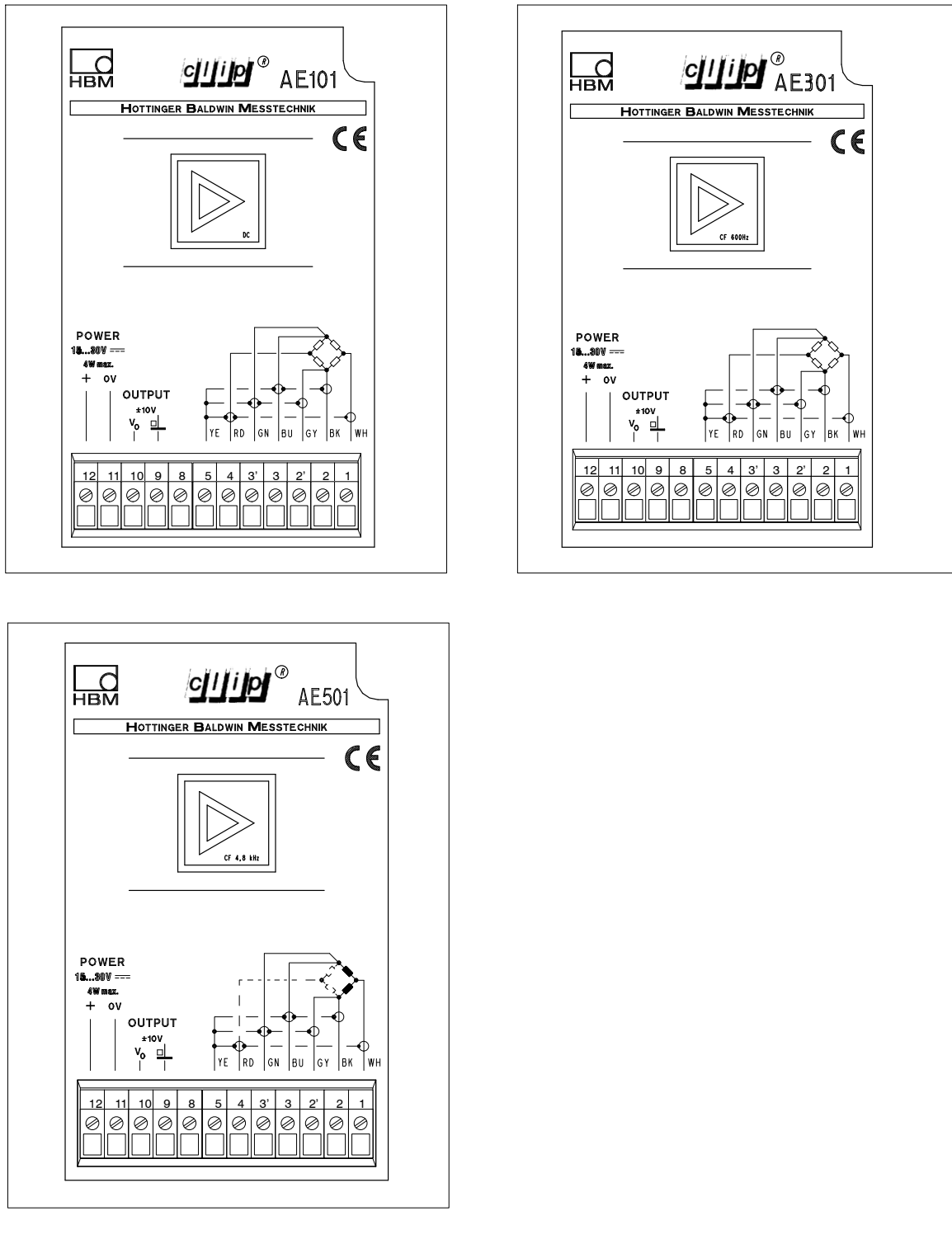

Fig. 3.1: Measuring-amplifier connections

Type	AE101, AE301, AE501	
Terminal	Function	Color ( HBM - cable)
1	Measuring signal	WH (white)
2	Bridge excitation voltage	BK (black)
2'	Sensor line	GY (grey)
3	Bridge excitation voltage	BU (blue)
3'	Sensor line	GN (green)
4	Measuring signal	RD (red)
5	Screen/Ground	YE (yellow)
8	Synchronization (not with AE101)	
9	Operating-voltage zero <sup>*)</sup>	
10	Output voltage	
11	Supply voltage zero <sup>*)</sup>	
12	Supply voltage	

**Tab. 3.1:** Amplifier connection

<sup>\*)</sup> Operating-voltage zero and supply-voltage are internally connected.

Terminal 5 of the Clip amplifier and the transducer's screen connection should be grounded (e. g. connected to the screen rail). If the transducers are installed in a metallic housing with PG glands (e. g. control cabinet or ClipIG), a large area of the transducer screen must be in contact with the PG gland.

### 3.2 GR201, EM201, EM201K2, TS101 additional units

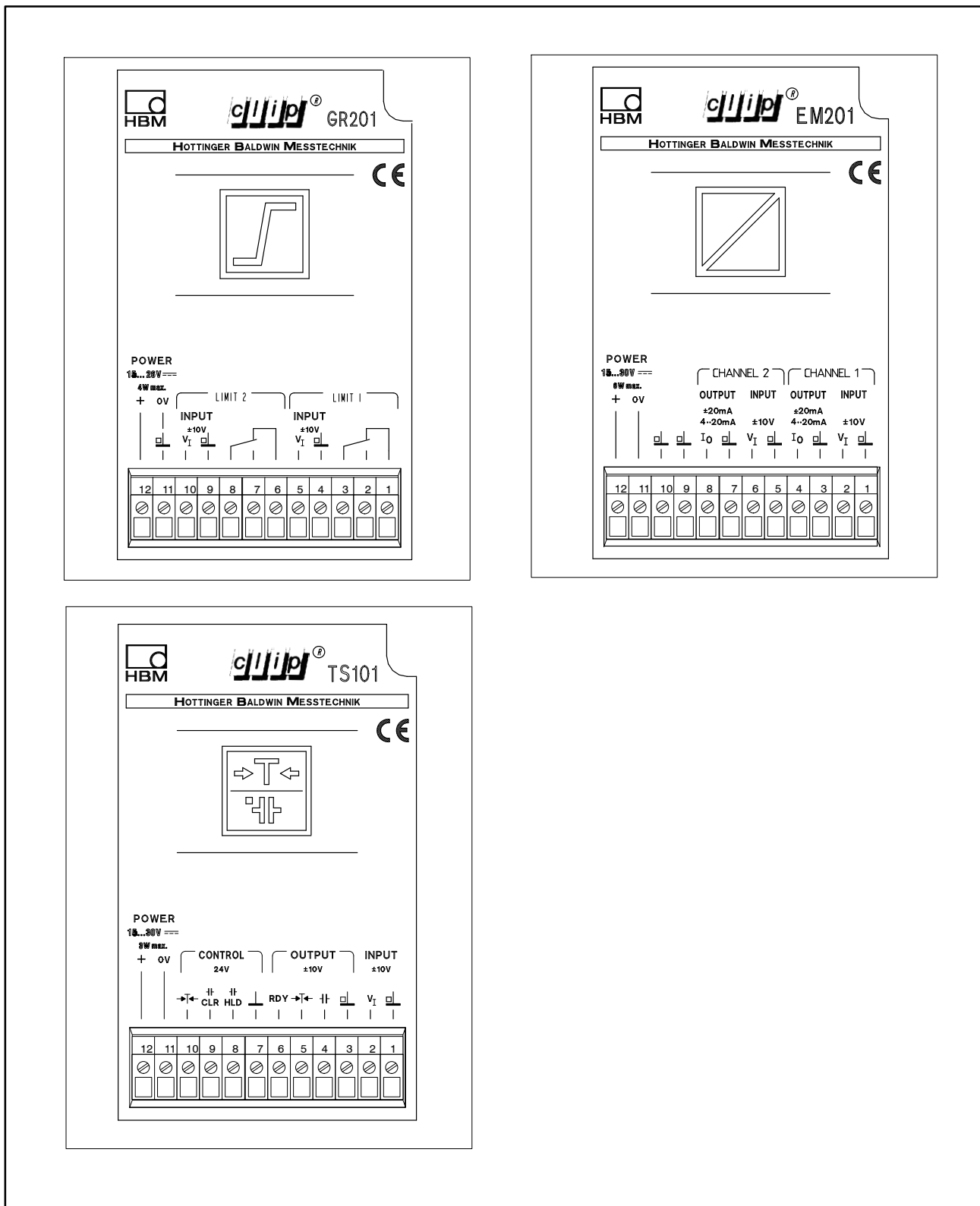

Fig. 3.2: Connection of the additional units

Type	GR201	EM201, EM201K2	TS101
<b>Terminal</b>	<b>Function</b>		
1	Relay 1; Break contact	Input 1; Ground*)	Input; Ground
2	Relay 1; Make contact	Input 1; $\pm 10$ V	Input ; $\pm 10$ V
3	Relay 1; Center	Output 1; Ground*)	Output; Ground
4	Input 1; Ground	Output 1; $\pm 20$ mA / 4 ... 20 mA	Output; PVCS $\pm 10$ V
5	Input 1; $\pm 10$ V	Input 2; Ground*) (only with EM201K2)	Output; TAR[ $\pm 10$ V
6	Relay 2; Break contact	Input 2; $\pm 10$ V (only with EM201K2)	Output; TAR (24 V DC)
7	Relay 2; Make contact	Output 2; Ground*) (only with EM201K2)	Control; Ground
8	Relay 2; Center	Output 2; $\pm 20$ mA / 4 ... 20 mA (only with EM201K2)	Control; Run/Hold (24 V DC)
9	Input 2; Ground	Ground*)	Control; Peak/Clear (24 V DC)
10	Input 2; $\pm 10$ V	Ground*)	Control; TAR (24 V DC)
11	Supply zero	Supply zero*)	Supply zero
12	Supply voltage	Supply voltage	Supply voltage

**Tab. 3.2:** Connection of additional units

\*) Ground and supply zero are internally connected. GR201 has differential inputs.

### 3.3 NT101A, NT102A Power supply

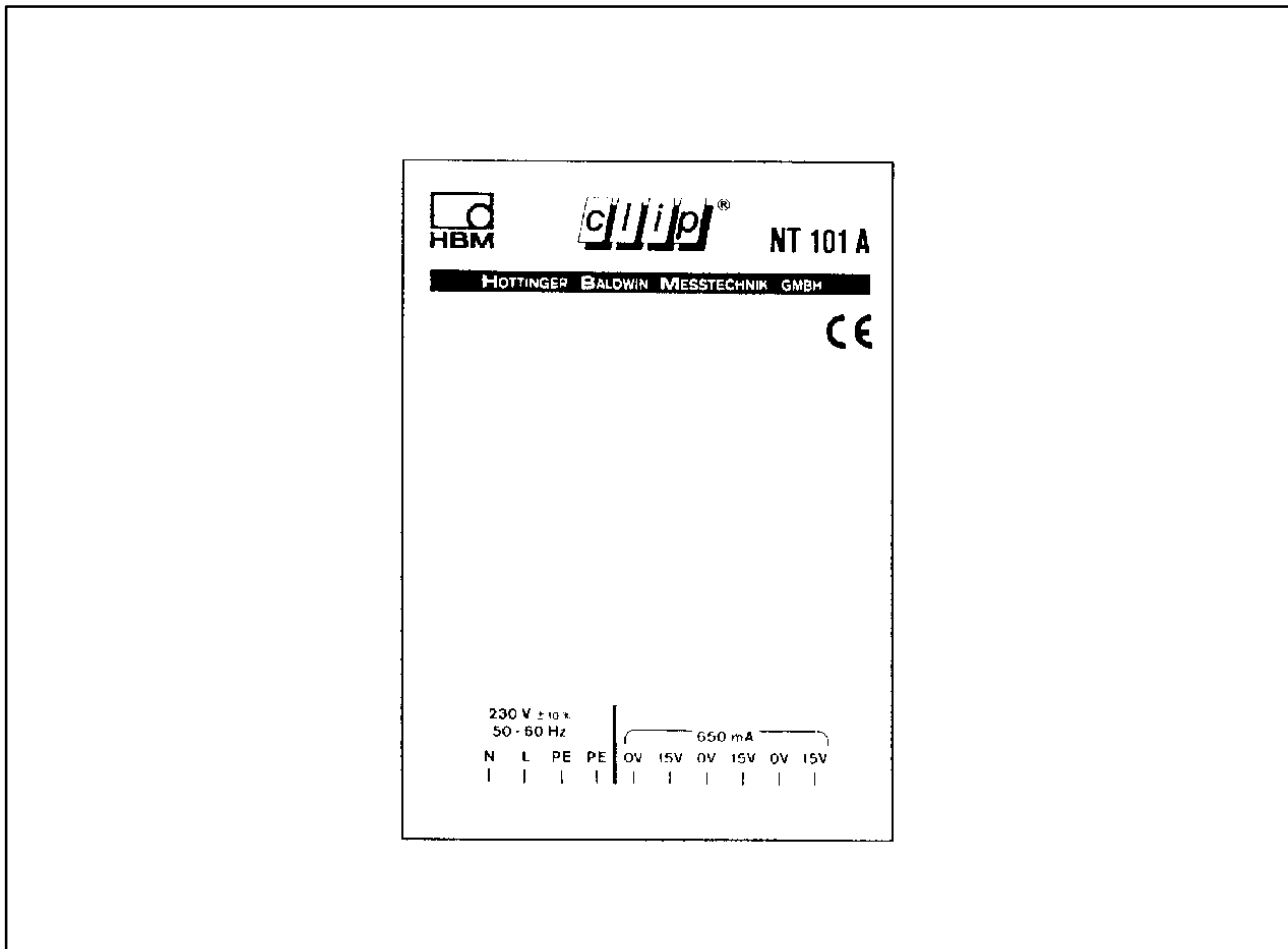

**Fig. 3.3:** Connection of the power supply

The mains voltage (230 V for NT101A, 115 V for NT102A) must be connected to N and L (phase); the protective ground wire must be connected to  $\oplus$ . The D.C.-voltage outputs are fed to pairs of internally connected terminals (0 V and 15 V). The max. output current is 650 mA.

## 4 Setup

If all cables are connected, proceed as follows:

- Connect transducer cable
- Switch on supply voltage.
- Slacken screw on upper right housing edge and hinge down housing cover.

### 4.1 AE101 Measuring amplifiers

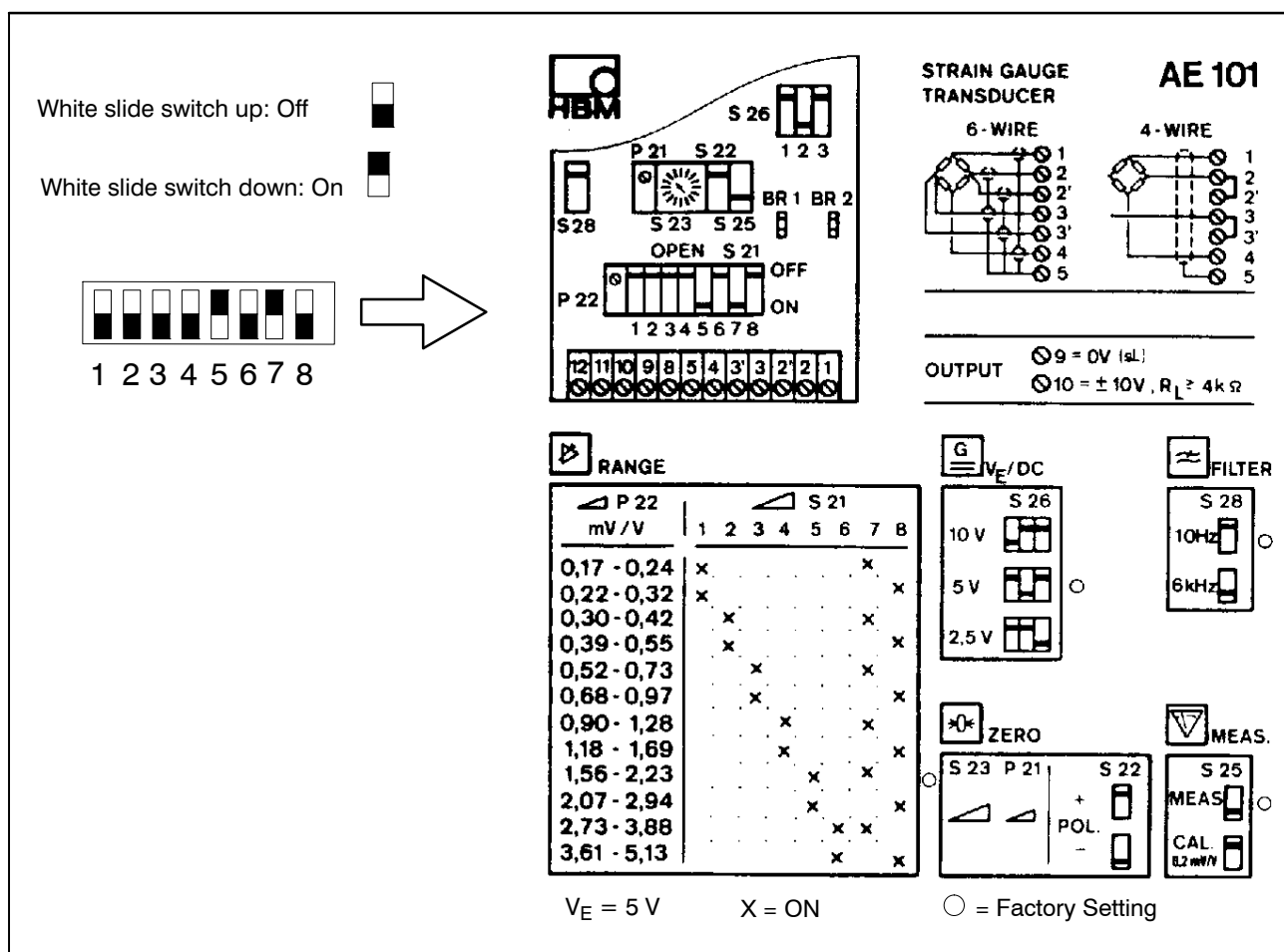

Fig. 4.1: Stick-on label in housing

#### • Connection method

The standard transducer connection-method is the 6-wire technique (with two sensor lines). If the transducer is to be connected using a 4-wire circuit, the terminals 2 and 2' and 3 and 3' must be provided with jumper wires.

- **Bridge excitation voltage**

Use switch S26 to select the bridge excitation voltage  $V_E$  according to the strain-gauge full-bridge's resistance  $R_B$ .

Bridge excitation voltage $V_E$	Transducer resistance $R_B$
10 V	340 ... 5000 $\Omega$
5 V	170 ... 5000 $\Omega$
2.5 V	85 ... 5000 $\Omega$

- **Measuring frequency range**

Use S28 to adjust the measuring frequency range to 10 Hz or 6 kHz.

- **Zero point**

- Discharge the transducer or charge with preload.
- Use digital voltmeter to measure output voltage, and use rotary switch S23 to adjust minimum indication (if necessary, use S22 to switch polarity); fine balancing with P21 to 0.000 V.

- **Measuring range**

To obtain the maximum measurement resolution, the max. amplifier output-voltage ( $\pm 10$  V) should be used.

AE101 $V_E = 2.5$ V mV/V	$V_E = 5$ V mV/V	$V_E = 10$ V mV/V	switch position S21								
			1	2	3	4	5	6	7	8	
0.34–0.48	0.17–0.24	0.09–0.12	X							X	
0.44–0.64	0.22–0.32	0.11–0.16	X								X
0.60–0.84	0.30–0.42	0.15–0.21		X						X	
0.78–1.1	0.39–0.55	0.20–0.28		X							X
1.04–1.46	0.52–0.73	0.26–0.37			X					X	
1.36–1.94	0.68–0.97	0.34–0.49			X						X
1.80–2.56	0.90–1.28	0.45–0.64				X				X	
2.36–3.38	1.18–1.69	0.59–0.85				X					X
3.12–4.46	1.56–2.23	0.78–1.12					X			X	
4.14–5.88	2.07–2.94	1.04–1.47					X				X
5.46–7.76	2.73–3.88	1.37–1.94						X	X		
7.22–10.26	3.61–5.13	1.81–2.57						X		X	

**Tab. 4.1:** Nominal measured value depending on the bridge excitation voltage  $V_E$ .



Formula:

$$\frac{\text{Part load}}{\text{Nominal load}} \cdot \frac{10 \text{ V}}{\text{Measuring range in V}} \cdot \text{Sensitivity in mV/V} = \text{Nominal measurement value (Range) in mV/V}$$

### Example 1

Force transducer 100 N  $\triangleq$  2 mV/V; measuring range wanted 60N  $\triangleq$  10 V

$$\frac{60 \text{ N}}{100 \text{ N}} \cdot \frac{10 \text{ V}}{10 \text{ V}} \cdot 2 \text{ mV/V} = 1.2 \text{ mV/V}$$

Load transducer with 60 N.

Use S21 to select appropriate interval as given in Tab. 4.1 (page 16) (switch on 4 + 7), and use P22 to adjust the output voltage to 10 V exactly. The measuring range can also be adjusted with no transducer connected by means of a calibration unit (e.g. K 3607) that simulates the transducer signal.

- **Additive calibration signal**

The measuring range can also be adjusted using the additive calibration signal (0.2 mV/V).

### Example 2

Force transducer 100 N  $\triangleq$  2 mV/V; measuring range wanted: 60 N  $\triangleq$  10 V

$$\frac{60 \text{ N}}{100 \text{ N}} \cdot \frac{10 \text{ V}}{10 \text{ V}} \cdot 2 \text{ mV/V} = 1.2 \text{ mV/V}$$

Calculate nominal measurement value, execute zero balance (see above) and use S21 to select the corresponding measuring-range interval. Connect additive calibration signal (set S25 to CAL) and use P22 to adjust with the transducer under no load. The amplifier has now been calibrated. Adjust S25 to MEAS.

$$\frac{0.2 \text{ mV/V}}{1.2 \text{ mV/V}} \cdot 10 \text{ V} = 1.667 \text{ V}$$

## 4.2 AE301 Measuring amplifier

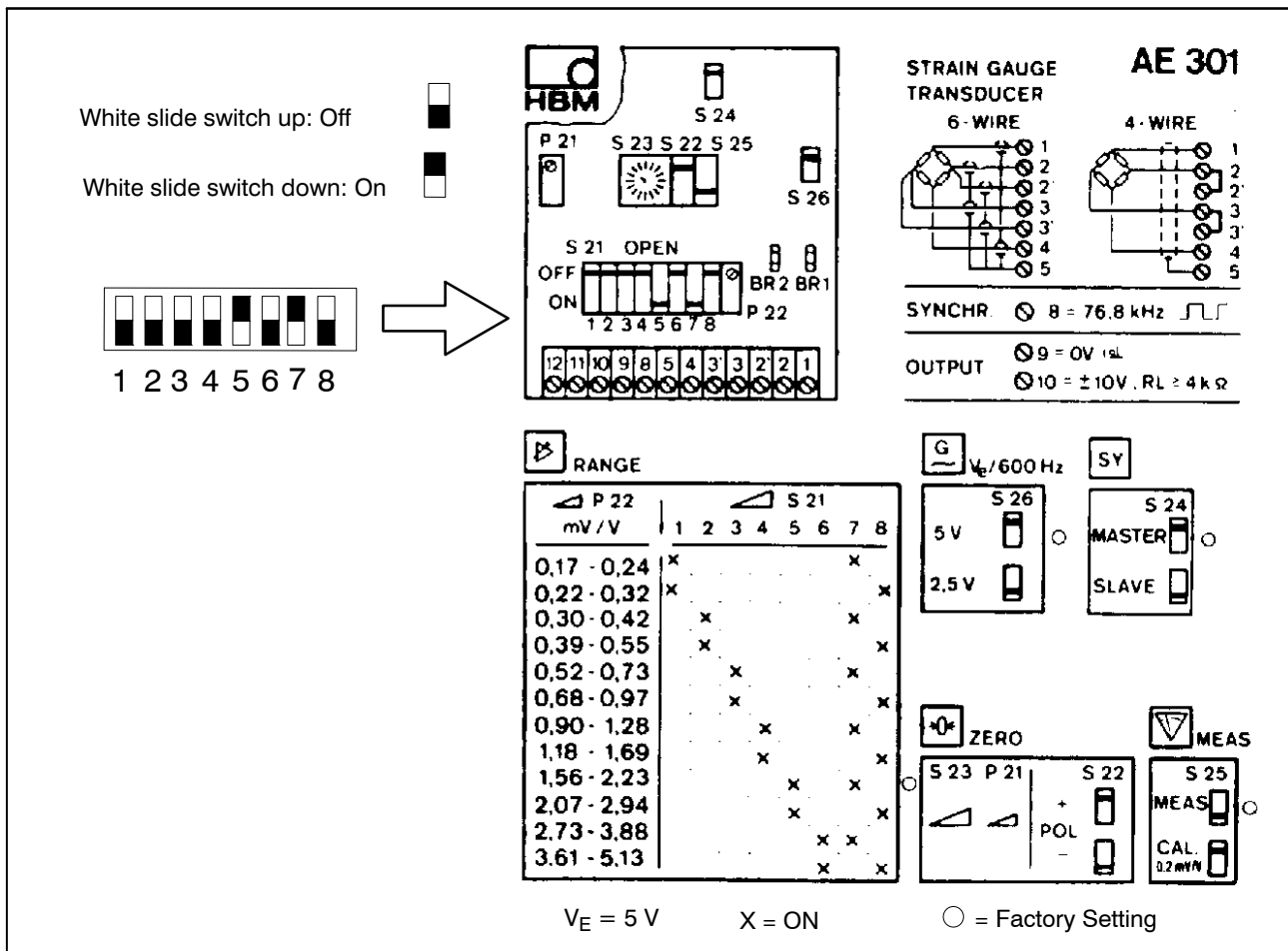

Fig. 4.2: Stick-on label in housing

### • Connection method

The standard transducer connection-method is the 6-wire technique (with two sensor lines). Cable lengths > 50 m require one resistor each with half the bridge resistance value ( $R_B/2$ ) to be connected to the sensor line instead of the feedback bridges. If the transducer is to be connected using a 4-wire circuit, the terminals 2 and 2' and 3 and 3' must be provided with jumper wires.

### • Bridge excitation voltage

Use switch S26 to select the bridge excitation voltage  $V_E$  according to the strain-gauge full-bridge's resistance  $R_B$ .

Bridge excitation voltage $V_E$	Transducer resistance $R_B$
5 V	170 ... 5000 $\Omega$
2.5 V	85 ... 5000 $\Omega$

- **Measuring frequency range**

The measuring frequency range is 10 Hz.

- **Zero point**

- Discharge the transducer or charge with preload.
- Use digital voltmeter to measure output voltage, and use rotary switch S23 to adjust minimum indication (if necessary, use S22 to switch polarity); fine balancing with P21 to 0.000 V.

- **Measuring range**

To obtain the maximum measurement resolution, the max. amplifier output-voltage ( $\pm 10$  V) should be used.

AE301									
$V_E = 2.5$ V	$V_E = 5$ V	switch position S21							
mV/V	mV/V	1	2	3	4	5	6	7	8
0.34–0.48	0.17–0.24	X						X	
0.44–0.64	0.22–0.32	X							X
0.60–0.84	0.30–0.42		X					X	
0.78–1.1	0.39–0.55		X						X
1.04–1.46	0.52–0.73			X				X	
1.36–1.94	0.68–0.97			X					X
1.80–2.56	0.90–1.28				X			X	
2.36–3.38	1.18–1.69				X				X
3.12–4.46	1.56–2.23					X		X	
4.14–5.88	2.07–2.94					X			X
5.46–7.76	2.73–3.88						X	X	
7.22–10.26	3.61–5.13						X		X

**Tab. 4.2:** Nominal measured value depending on the bridge excitation voltage  $V_E$

Factory setting:  $V_E = 5$  V;  $M_R = 2$  mV/V

AE301S6									
Measuring frequency range: 2 Hz									
Calibration signal: 0.1 mV/V									
$V_E=2.5\text{ V}$	$V_E=5\text{ V}$	switch S21							
mV/V	mV/V	1	2	3	4	5	6	7	8
0.17–0.24	0.09–0.12	X						X	
0.22–0.32	0.11–0.16	X							X
0.30–0.42	0.15–0.21		X					X	
0.39–0.55	0.20–0.28		X						X
0.52–0.73	0.26–0.37			X				X	
0.68–0.97	0.34–0.49			X					X
0.90–1.28	0.45–0.64				X			X	
1.18–1.69	0.59–0.85				X				X
1.56–2.23	0.78–1.12					X		X	
2.07–2.94	1.04–1.47					X			X
2.73–3.88	1.37–1.94						X	X	
3.61–5.13	1.81–2.57						X		X

Factory setting:  $V_E=5\text{ V}$ ;  $M_R=1\text{ mV/V}$

AE301S7									
Measuring frequency range: 60 Hz									
Calibration signal: 0.1 mV/V									
$V_E=2.5\text{ V}$	$V_E=5\text{ V}$	switch S21							
mV/V	mV/V	1	2	3	4	5	6	7	8
0.17–0.24	0.09–0.12	X						X	
0.22–0.32	0.11–0.16	X							X
0.30–0.42	0.15–0.21		X					X	
0.39–0.55	0.20–0.28		X						X
0.52–0.73	0.26–0.37			X				X	
0.68–0.97	0.34–0.49			X					X
0.90–1.28	0.45–0.64				X			X	
1.18–1.69	0.59–0.85				X				X
1.56–2.23	0.78–1.12					X		X	
2.07–2.94	1.04–1.47					X			X
2.73–3.88	1.37–1.94						X	X	
3.61–5.13	1.81–2.57						X		X

Factory setting:  $V_E=5\text{ V}$ ;  $M_R=1\text{ mV/V}$

Formula:

$$\frac{\text{Part load}}{\text{Nominal load}} \cdot \frac{10\text{ V}}{\text{Measuring range in V}} \cdot \text{Sensitivity in mV/V} = \text{Nominal measurement value (Range) in mV/V}$$

**Example 3**

Force transducer 100 N  $\underline{\Delta}$  2 m V/V; measuring range wanted: 60 N  $\underline{\Delta}$  10 V

$$\frac{60 \text{ N}}{100 \text{ N}} \cdot \frac{10 \text{ V}}{10 \text{ V}} \cdot 2 \text{ mV/V} = 1.2 \text{ mV/V}$$

Load transducer with 60 N.

Use S21 to select appropriate interval as given in Tab. 4.2 (page 19) (switch on 4 + 7), and use P22 to adjust the output voltage to 10 V exactly. The measuring range can also be adjusted with no transducer connected by means of a calibration unit (e.g. K 3607) that simulates the transducer signal.

- **Additive calibration signal**

The measuring range can also be adjusted using the additive calibration signal (0.2 mV/V).

**Example 4**

Force transducer 100 N  $\underline{\Delta}$  2mV/V; measuring range wanted: 60 N  $\underline{\Delta}$  10 V

$$\frac{60 \text{ N}}{100 \text{ N}} \cdot \frac{10 \text{ V}}{10 \text{ V}} \cdot 2 \text{ mV/V} = 1.2 \text{ mV/V}$$

Calculate nominal measurement value, execute zero balance (see above) and use S21 to select the corresponding measuring-range interval. Connect additive calibration signal (set S25 to CAL) and use P22 to adjust with the transducer under no load. The amplifier has now been calibrated. Adjust S25 to MEAS.

$$\frac{0.2 \text{ mV/V}}{1.2 \text{ mV/V}} \cdot 10 \text{ V} = 1.667 \text{ V}$$

- **Synchronization**

For synchronization of several CF amplifiers, one master device must be defined by adjusting S24 to MASTER. The other devices must be set to SLAVE using S24. Then, interconnect terminals 8. Synchronization is also possible with AE501 measuring amplifiers.

### 4.3 AE501 Measuring amplifier

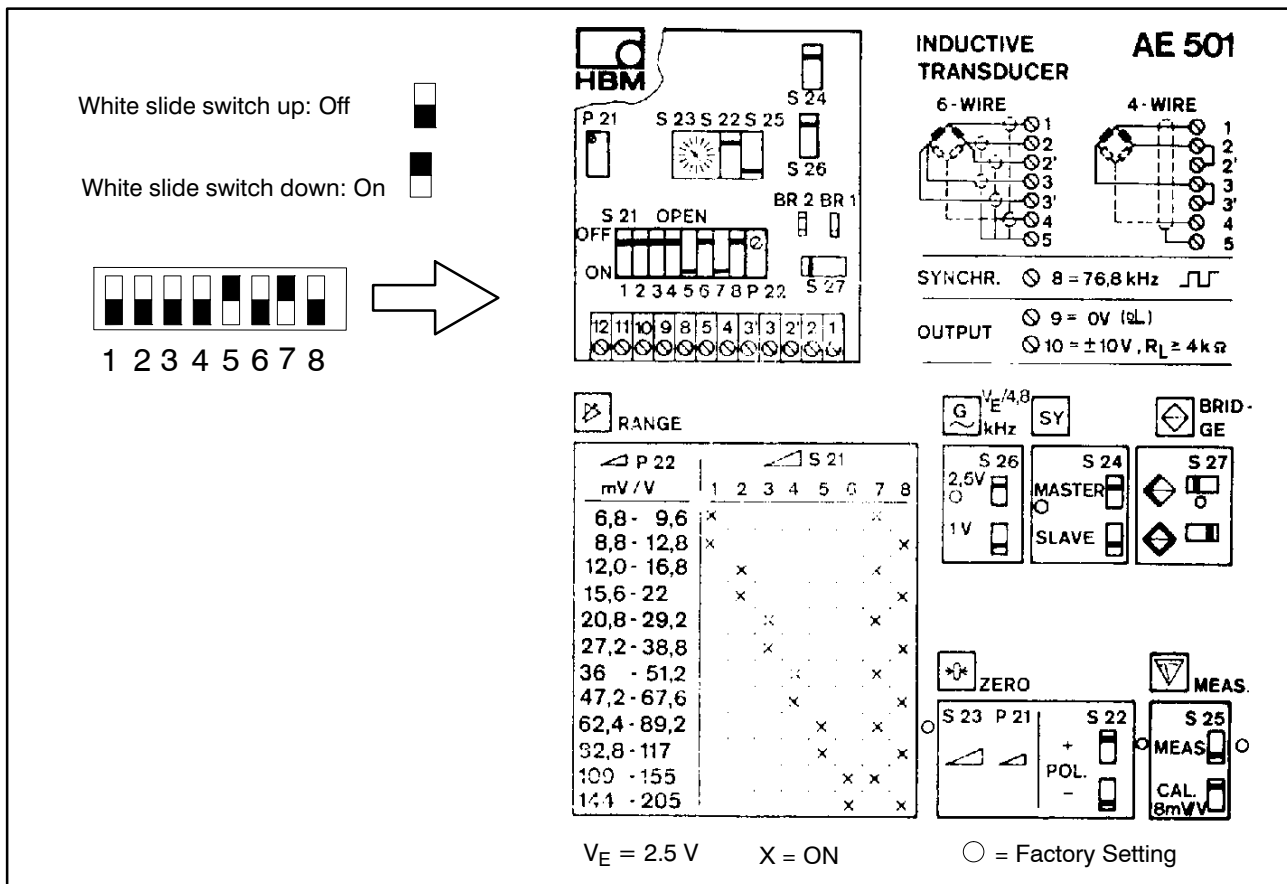

Fig. 4.3: Stick-on label in housing

#### • Connection method

The standard transducer connection-method for inductive halfbridges is the 5-wire technique for inductive fullbridges the 6-wire technique. If the transducer is to be connected using a 3-wire circuit (inductive half bridge) or a 4-wire circuit (inductive full bridge), the terminals 2 and 2' and 3 and 3' must be provided with jumper wires.

#### • Bridge type

Use switch S27 to select the bridge type (inductive half bridge, inductive full bridge).

#### • Bridge excitation voltage

Use switch S26 to select the bridge excitation voltage  $V_E$  according to the inductance  $L_B$  of the half-bridge or full-bridge transducer. When using SI01 safety barriers, the bridge excitation voltage **must** in any case be adjusted to 1 V.

Bridge excitation voltage $V_E$	Transducer inductance $L_B$
2.5 V	2.5 ... 20 mH
1 V	6 ... 19 mH

- **Measuring frequency range**

The measuring frequency range is 10 Hz.

- **Zero point**

- Bring transducer into initial position (e.g. mechanical center position).
- Use digital voltmeter to measure output voltage, and use rotary switch S23 to adjust minimum indication (if necessary, use S22 to switch polarity); fine balancing with P21 to 0.000 V.

- **Measuring range**

To obtain the maximum measurement resolution, the max. amplifier output-voltage ( $\pm 10$  V) should be used.

AE501									
$V_E = 1$ V	$V_E = 2.5$ V	switch position S21							
mV/V	mV/V	1	2	3	4	5	6	7	8
17.0–24.0	6.8–9.6	X						X	
22.0–32.0	8.8–12.8	X							X
30.0–42.0	12.0–16.8		X					X	
39.0–55.0	15.6–22.0		X						X
52.0–73.0	20.8–29.2			X				X	
68.0–97.0	27.2–38.8			X					X
90.0–128.0	36.0–51.2				X			X	
118.0–169.0	47.2–67.6				X				X
156.0–223.0	62.4–89.2					X		X	
207.0–292.5	82.8–117.0					X			X
272.0–387.5	109.0–155.0						X	X	
360.0–512.5	144.0–205.0						X		X

**Tab. 4.3:** Nominal displacement depending on the bridge excitation voltage  $V_E$

Formula:
$\frac{\text{Part load}}{\text{Nominal load}} \cdot \frac{10 \text{ V}}{\text{Measuring range in V}} \cdot \text{Sensitivity in mV/V} = \text{Nominal measurement value (Range) in mV/V}$

**Example 5**

Displacement transducer, nominal displacement  $\pm 20 \text{ mm} \triangleq \pm 80 \text{ mV/V}$   
 Measuring range wanted:  $16 \text{ mm} \triangleq 10 \text{ V}$

$$\frac{16 \text{ mm}}{20 \text{ mm}} \cdot \frac{10 \text{ V}}{10 \text{ V}} \cdot 80 \text{ mV/V} = 64 \text{ mV/V}$$

Position transducer to 16mm displacement, e.g. using gauge blocks. Use S21 to select the appropriate interval as given in Tab. 4.3 (page 23) (switch on 4 + 8), and use P22 to adjust the output voltage to 10V exactly. The measuring range can also be adjusted with no transducer connected by means of a calibration unit (e.g. BN 4800) that simulates the transducer signal.

- **Additive calibration signal**

The measuring range can also be adjusted using the additive calibration signal (8mV/V).

**Example 6**

Displacement transducer, nominal displacement  $\pm 20 \text{ mm} \triangleq \pm 80 \text{ mV/V}$ ;  
 Measuring range wanted:  $16 \text{ mm} \triangleq 10 \text{ V}$ .

$$\frac{16 \text{ mm}}{20 \text{ mm}} \cdot \frac{10 \text{ V}}{10 \text{ V}} \cdot 80 \text{ mV/V} = 64 \text{ mV/V}$$

Calculate nominal measurement, execute zero balance (see above) and use S21 to select the corresponding measuring-range interval. Activate additive calibration signal (set S25 to CAL) and use P22 to adjust with the transducer in displaced position. The amplifier has now been calibrated. Adjust S25 to MEAS.

$$\frac{8 \text{ mV/V}}{64 \text{ mV/V}} \cdot 10 \text{ V} = 1.250 \text{ V}$$

- **Synchronization**

The maximum number of modules that can be synchronized is 16.

For synchronization of several CF amplifiers, one master device must be defined by adjusting S24 to MASTER; the other devices must be set to SLAVE using S24. Then, interconnect terminals 8. Synchronization is also possible with AE301 measuring amplifiers.



## 4.4 GR201 Double limit-value switch

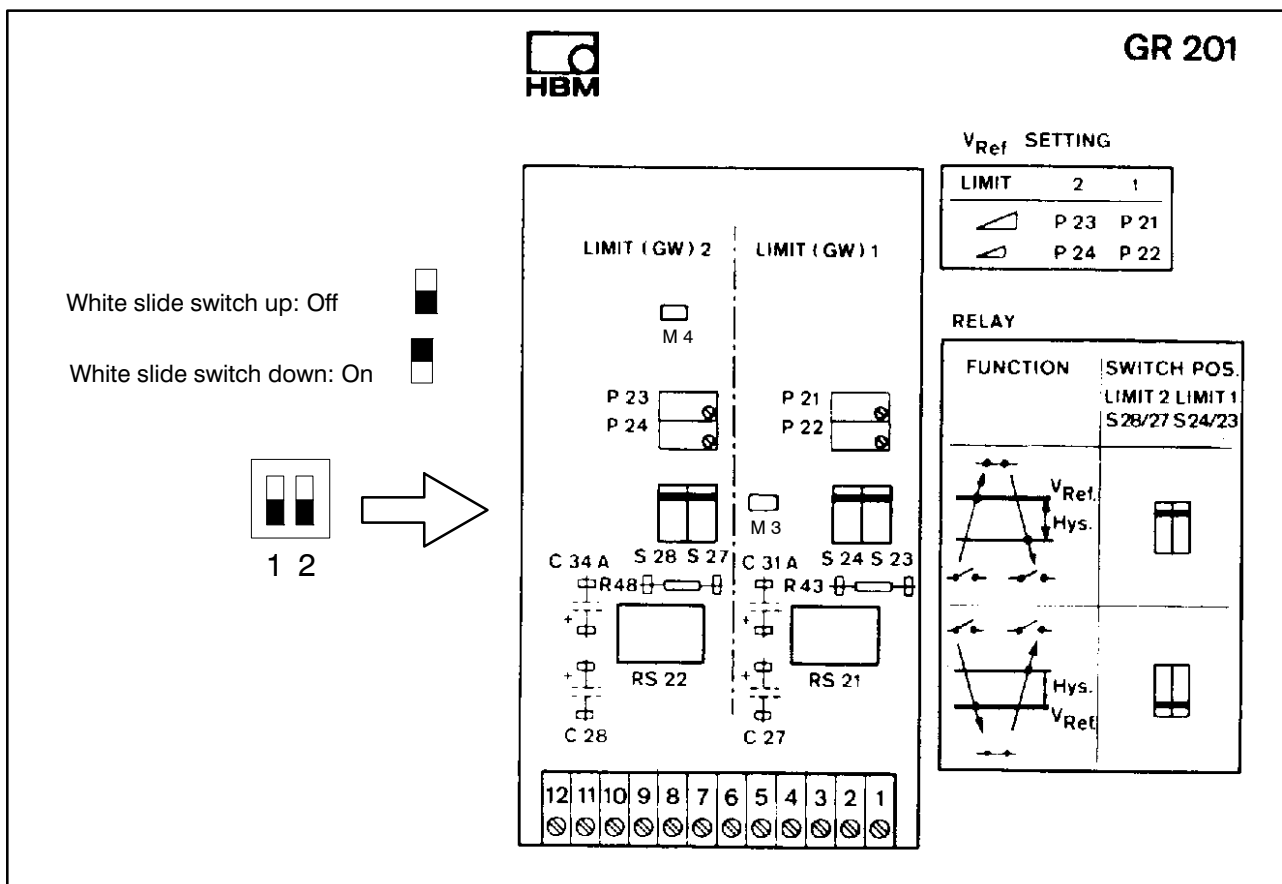

Fig. 4.4: Stick-on label in housing

### • Reference voltage

Use the potentiometers P21 (coarse) and P22 (fine) for limit 1 or P23 (coarse) and P24 (fine) for limit 2 to adjust the relay response point (reference voltages  $V_{Ref1}$  and  $V_{Ref2}$ ). The reference voltages  $V_{Ref1}$  and  $V_{Ref2}$  are available at the measuring points M4 (for limit1) and M5 (for limit 2). Connect a digital voltmeter to adjust the reference voltages as follows:

Limit 1 to measuring point M4 and terminal 4

Limit 2 to measuring point M3 and terminal 9



### CAUTION

When the amplifier and limit value switch are supplied from several power supply units their ground connections have to be interconnected.

- **Switching direction**

There are two possible switching directions.

1. S23/24 and S27/28 in upper position

The make contact (terminal 2 or 7) closes upon exceeding of reference voltage  $V_{Ref}$  and opens upon falling below reference voltage  $V_{Ref}$  minus the hysteresis voltage  $V_{Hys}$ .

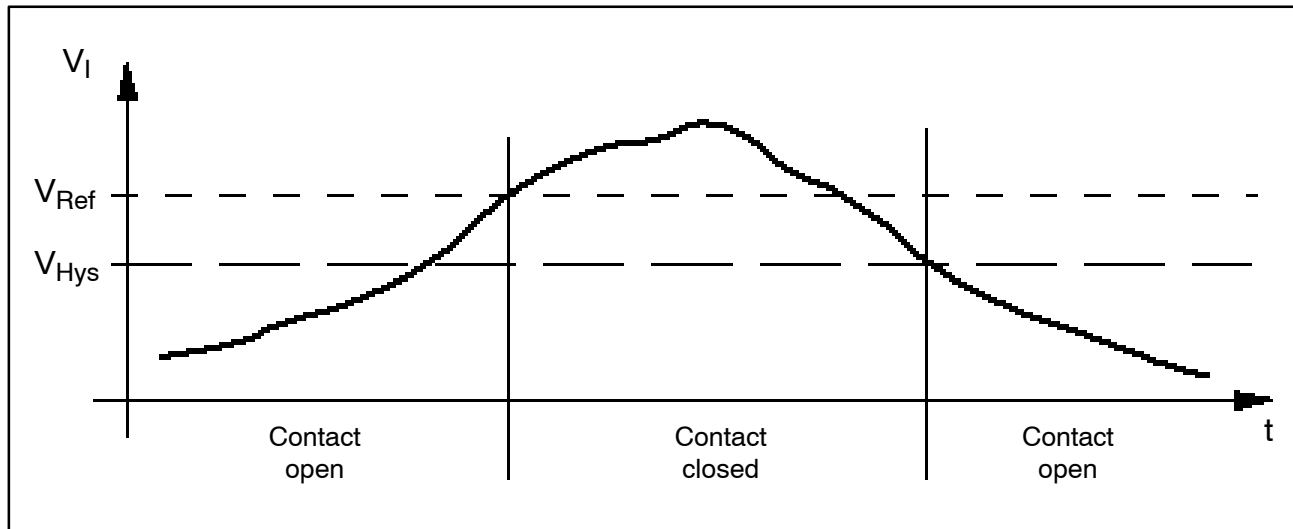

**Fig. 4.5:** GR201 Switching behavior, S23/24 and S27/28 in upper position

2. S23/24 or S27/28 in lower position

The make contact (terminal 2 or 7) closes upon falling below reference voltage  $V_{Ref}$  and opens upon exceeding of reference voltage  $V_{Ref}$  plus the hysteresis voltage  $V_{Hys}$ .

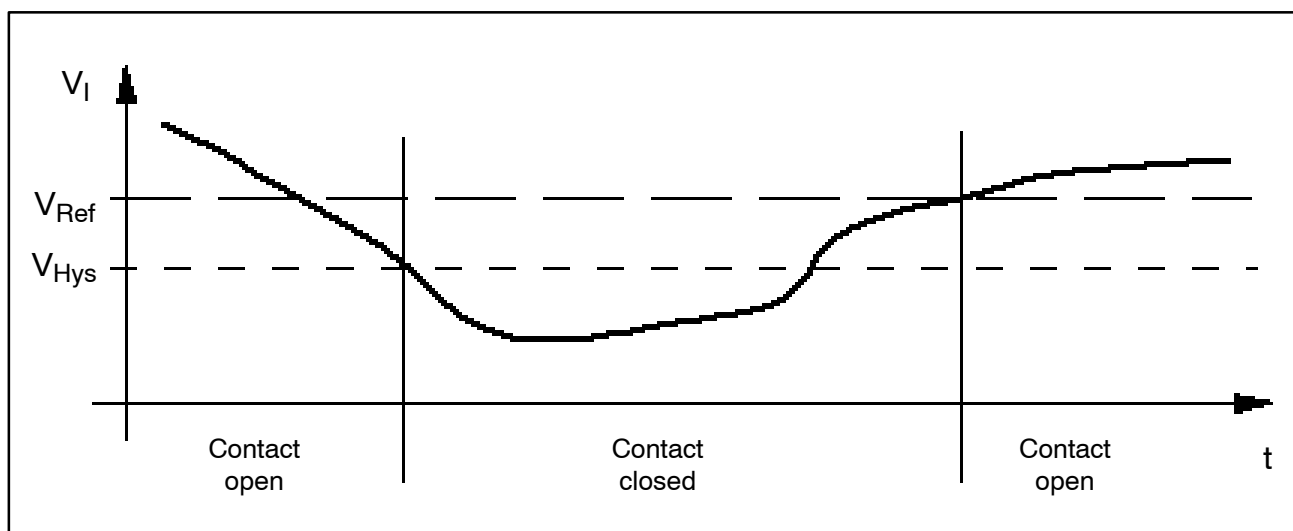

**Fig. 4.6:** GR201 Switching behavior, S23/24 and S27/28 in lower position



## NOTE

Under normal operating conditions, the relays switch as described at  $V_{Ref}$  or  $V_{Hys}$  respectively. With signal levels in the hysteresis range ( $V_{Ref} - V_{Hys}$  or  $V_{Hys} - V_{Ref}$ ), EMC influences may cause the relays to switch before  $V_{Ref}$  or  $V_{Hys}$  has been reached. Outside the hysteresis range the switching states are always unambiguous.

- **Changing the hysteresis voltage**

The hysteresis voltage is 220 mV. It can be varied by changing R43 resp. R48. The following applies:

$$R43 (R48) = \frac{670 \text{ mV}}{V_{Hys} [\text{mV}]} \text{ k}\Omega$$

- **Changing the response and releasing times**

The response/releasing time ( $t_{rise}$ ,  $t_{fall}$ ) is less than 5ms. It can be varied by changing C31a/C34a and C27/C28 (max. 6.8 $\mu$ F). The capacitor's dielectric strength must be  $\geq 35$  V. The following applies:

$$t_{rise} = \frac{18 \text{ ms} \cdot C31a (C34a)}{\mu\text{F}} + 3 \text{ ms}$$

$$t_{fall} = \frac{710 \text{ ms} \cdot C31a (C34a)}{\mu\text{F}} + 3 \text{ ms}$$

- **Changing the releasing time only**

Change C27 (C28) to vary the relay releasing times (max. 47 $\mu$ F). The following applies:

$$t_{fall} = \frac{6 \text{ ms} \cdot C27 (C28)}{\mu\text{F}} + 3 \text{ ms}$$

## 4.5 EM201 / EM201K2 Output stage

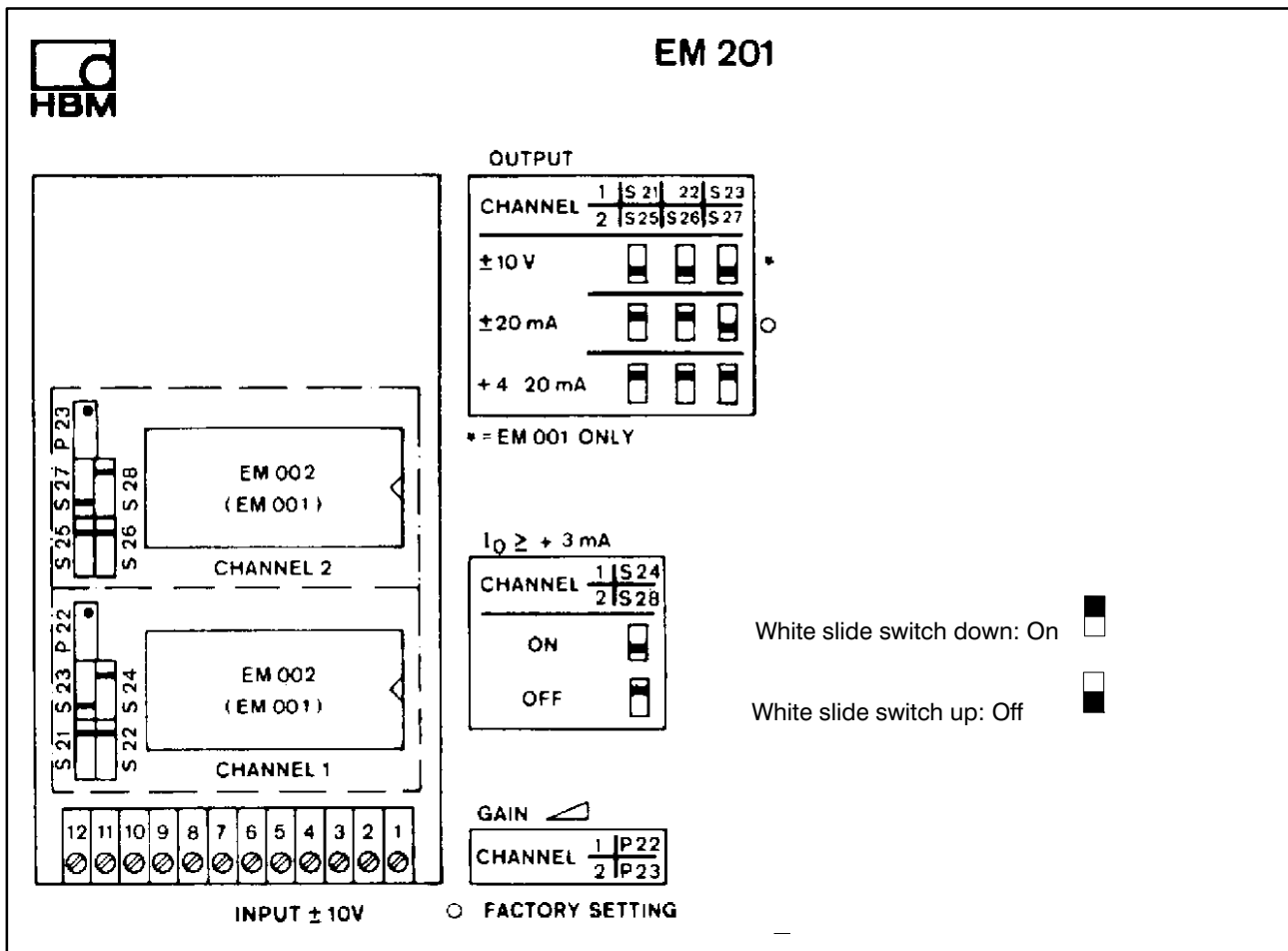

**Fig. 4.7:** Stick-on label in housing

The EM201 Output stage has been equipped with *one* EM002 module, the EM201K2 Output stage has been equipped with *two* EM002 modules. The EM002 module converts the amplifier output-voltage into a proportional current signal. For both versions the same housing has been used. Depending on the switch positions, the following current outputs are available:

- **± 20 mA current output**
  - S21/22 (S25/26) in upper position
  - S23 (S27) in lower position
  - S24 (S28) in OFF position
- **4 ... 20 mA current output**
  - S21/22 (S25/26) in upper position
  - S23 (S27) in upper position
  - S24 (S28) in ON/OFF position

With S24 (S28) ON, the minimum output current is 3 mA. Even with negative input voltages, this value will not be fallen below. Consequently, a following device that monitors an interruption of cable, for example, will not respond erroneously, or an externally supplied following device will be supplied continuously.

- **Gain**

Use P22 (P23) to adjust the gain for both output stages in the range of 0.9 ... 1.1. Instead of the EM002 module, the EM001 module can also be used. It makes available an additional  $\pm 10 \text{ V}/20 \text{ mA}$  voltage output. A separate zero balance is also possible.

- **Zero balance**

Since a zero balance is not provided in the EM002 module, the zero point has to be adjusted on the amplifier.

## 5 TS101 Automatic tare and store unit

### 5.1 General

The TS101 automatic tare and store unit is an additional Clip electronics module for further signal processing. The TS101 enables signals supplied by an amplifier connected in series to be tared and stored.

### 5.2 Function

The TS101 enables the below functions to be activated **at the same time**:

- tare **and** save a current value or a peak value (Minimum value or maximum value or peak-to-peak-value or envelope curve)

or

- save minimum value and maximum value (no taring)

#### 5.2.1 Taring

Use the "Tare" control input (terminal 10) to start taring. To ensure correct acquisition of the tare value even in the case of unstable input signals, an adjustable low-pass can be used to filter the tare unit's input signal. In addition, the net signal can be amplified.

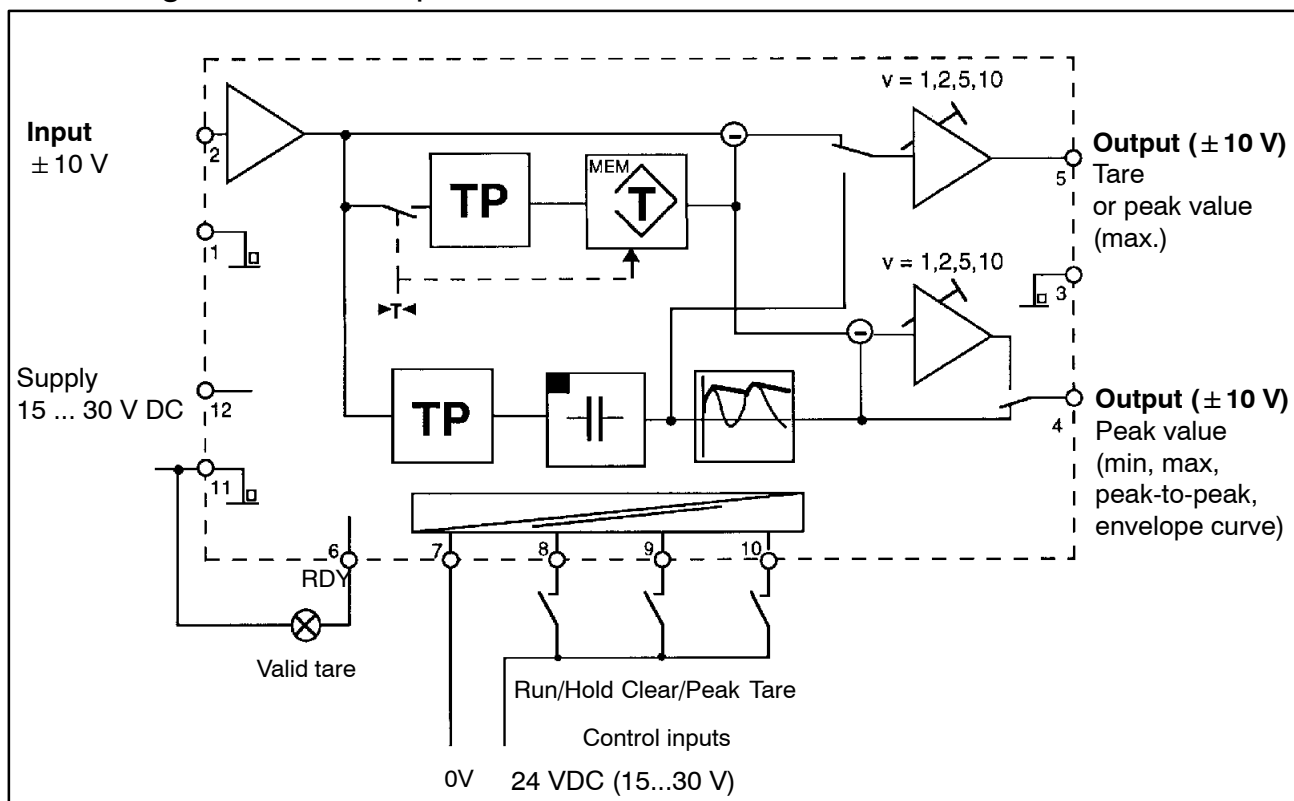

Fig. 5.1: Block diagram

## 5.2.2 Store unit

Upon storage, you can select as input signal for the store unit either the amplifier signal (gross signal) or the tare unit's output signal (net signal, not amplified). The selected input signal as well can be filtered and amplified. Use terminals 8 and 9 to control the store unit's operating mode (current value/peak value) and the Run/Hold function. With the "High" level the control output (RDY) signals a valid tare value.

- **Current value operating-mode**

When the store unit is used to acquire current values, the store contents is permanently kept up to date ("Run" function). Use the "Hold" control contact to hold the store contents; then, the value is present at the output as an analog signal.



### NOTE

**With the "Run" function, the TS101 output signal does correspond to the amplifier's output signal up to a frequency of 15 Hz.**

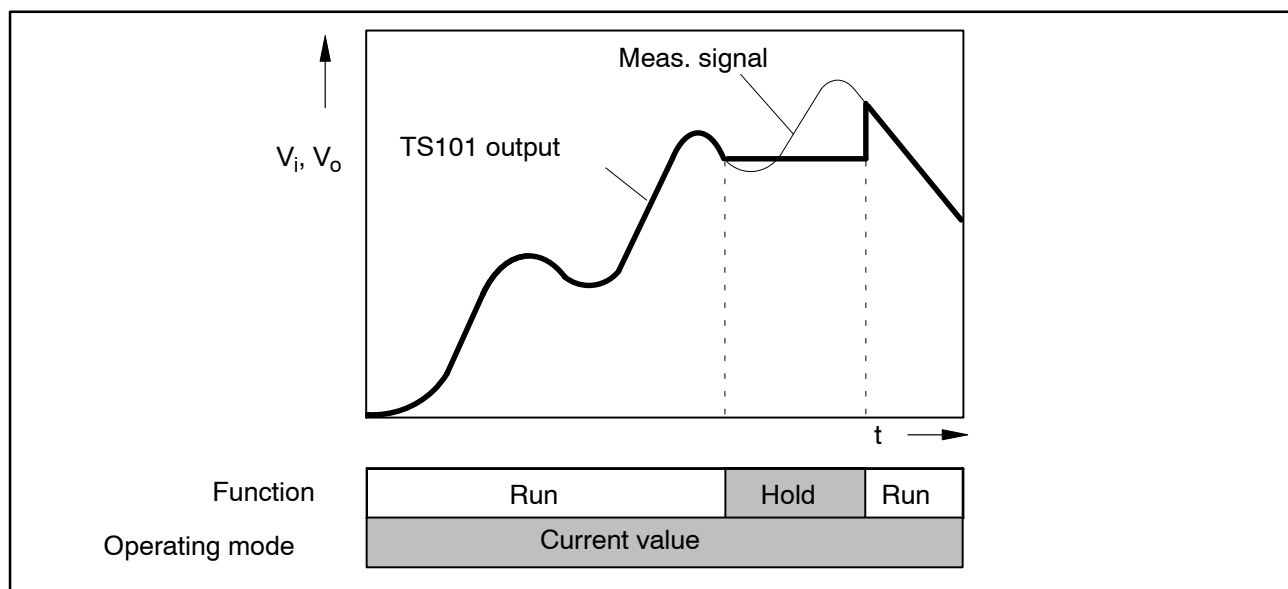

**Fig. 5.2:** Current value operating-mode (Clear)

### Peak value operating-mode

The peak value operating-mode enables the below values to be acquired:

- minimum value or
- maximum value or
- peak-to-peak values

Use the "Hold" control contact to hold the store contents.

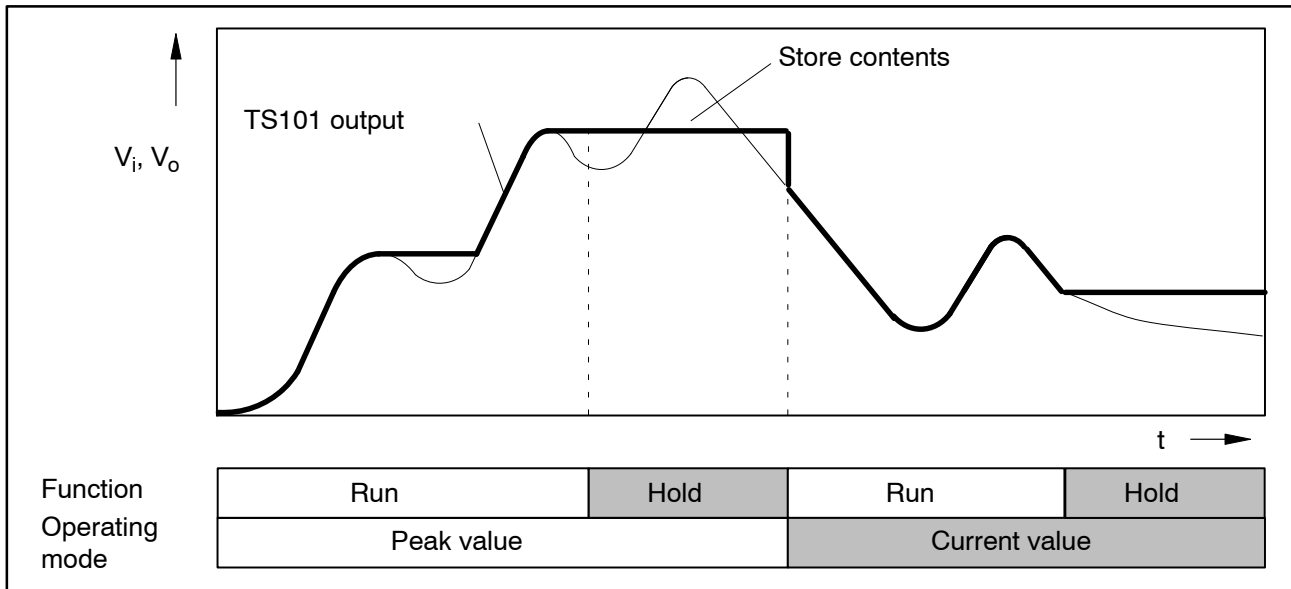

**Fig. 5.3:** Peak values operating-mode (PEAK)

Upon acquisition of peak values, enabling and adjusting the discharge rate enables an envelope-curve function to be prepared (Fig. 5.4 and Fig. 5.5). By adjusting the discharge rate you determine the speed of linear discharging of the peak-value store to the current value.

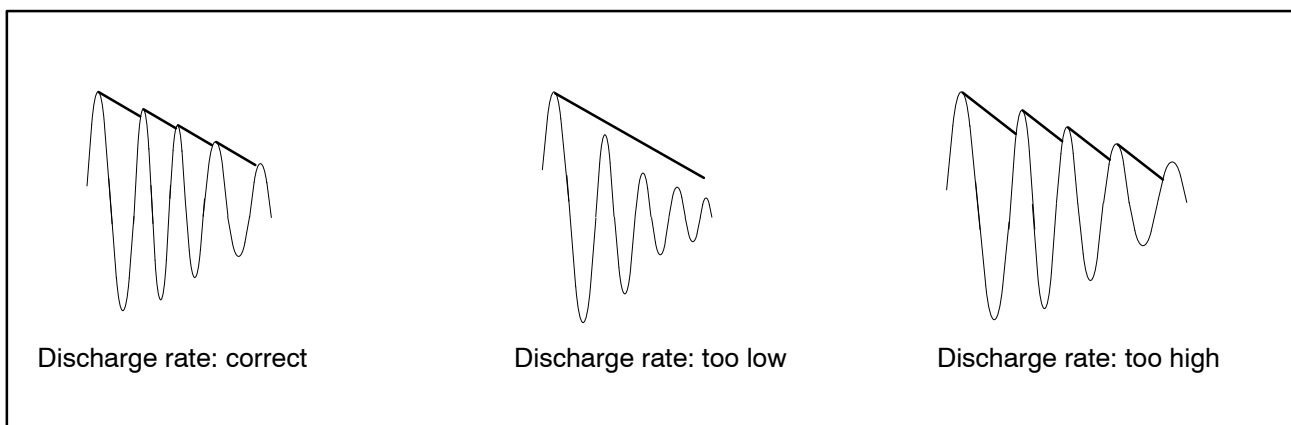

**Fig. 5.4:** Envelope-curve function



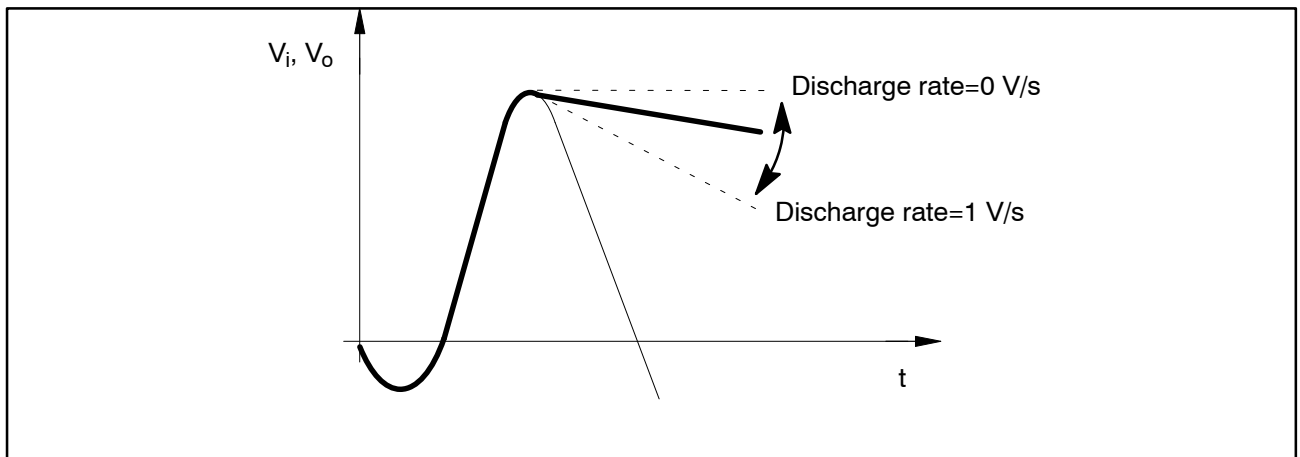
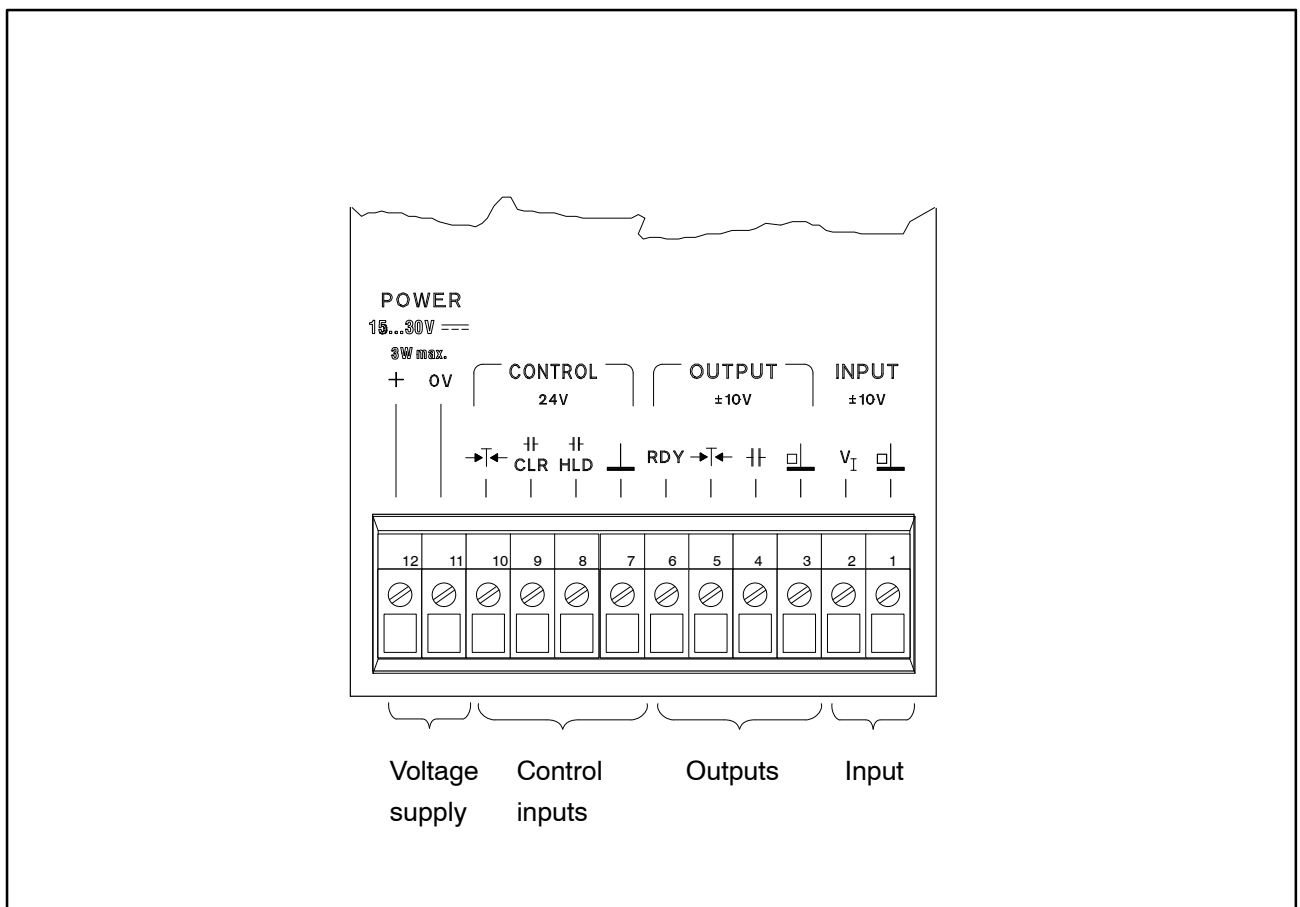

**Fig. 5.5:** Adjusting the discharge rate

### 5.3 Connection

Before starting up the device, read the safety instructions on page 4.

12 series terminals for wire diameters from 0.13 ... 1.5 mm (10 mm end sleeves for strands) are used to connect the TS101.



**Fig. 5.6:** TS101 connection terminals

Terminal	Function
1	Operating-voltage zero
2	Input voltage $\pm 10$ V
3	Operating-voltage zero
4	Peak-value store output-voltage $\pm 10$ V
5	Tare unit output-voltage $\pm 10$ V
6	Control output: valid tare (24 V DC)
7	Ground (external for control inputs)
8	Run/Hold peak-value store (24 V DC) control input
9	Peak/Clear peak-value store (24 V DC control input)
10	Tare (24 V DC control input)
11	Supply voltage 0 V
12	Supply voltage 15 ... 30 V DC (unregulated)

**Tab. 5.1:** Terminal assignment

### 5.3.1 Voltage supply

The automatic tare and store unit must be supplied with an external supply voltage of 15 V to 30 V. Terminals 11 and 12 are used for connection.

### 5.3.2 Inputs / Outputs

#### Inputs

Connect to terminals 1 and 2 the output signal supplied by the amplifier connected in series.

#### Outputs

The TS101 output signals can be picked up at terminal 4 (peak value) and terminal 5 (net value). They can be used as the input signal for an indicator (load resistance  $>5$  k $\Omega$ ) as shown in Fig. 5.7.



#### NOTE

**Screened cable should be used for the analog input and output signals to ensure proper functioning even if the components are exposed to high EMC-levels.**

### 5.3.3 Control inputs / Control output

The control inputs (terminals 7 ... 10) are electrically isolated from the processor. They must be connected to an external ground (e.g. PLC) and 24 V (as control signal).

Open control contacts correspond to the "Low" state ("Peak values" operating mode; "Run" function).

The RDY control output (terminal 6) signals a valid tare value. The signal level corresponds to the level of the supplied voltage (15 ... 30 V).

Fig. 5.7 shows the connections required for TS101 operation. For the terminal assignment refer to table Tab. 5.1.

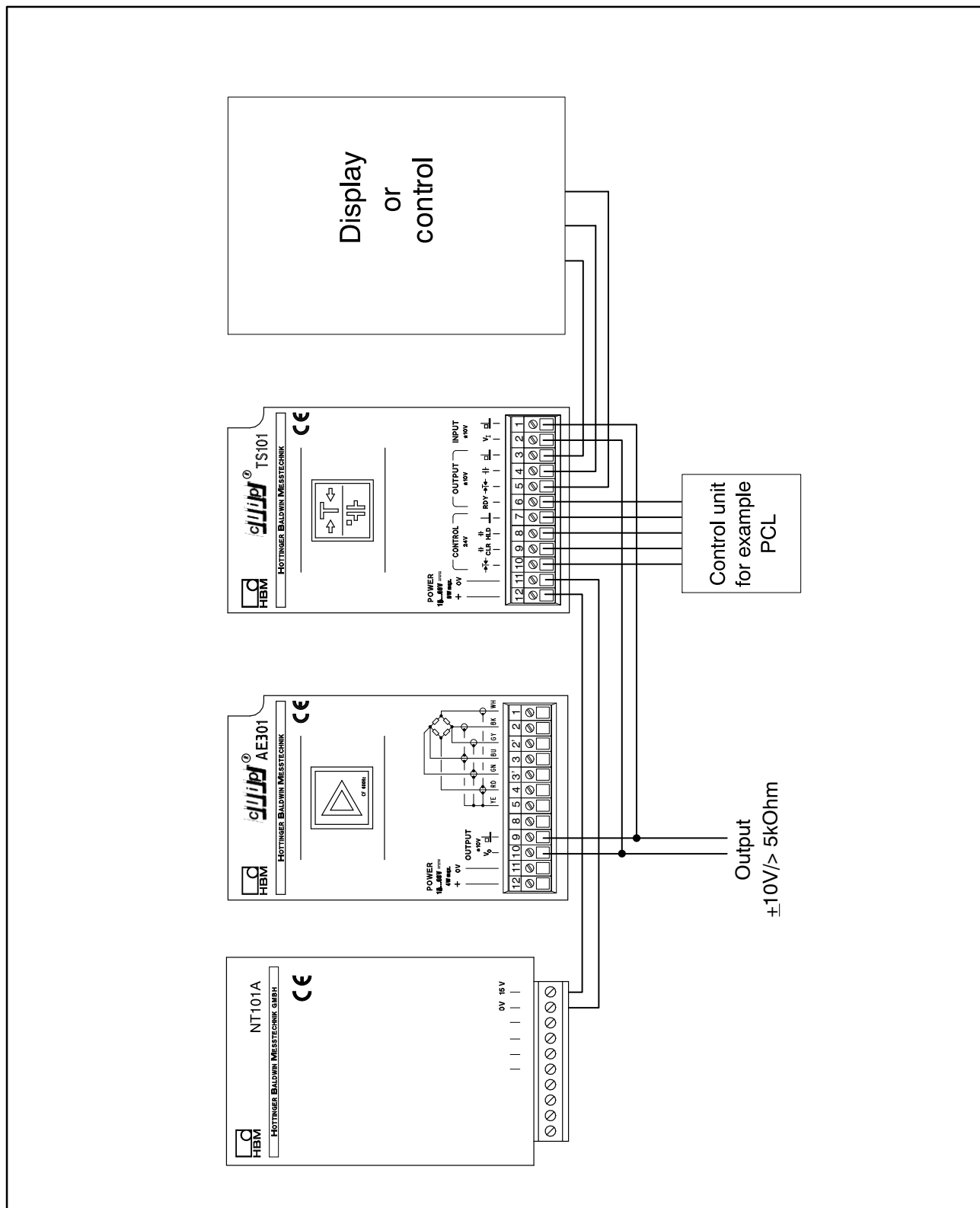

Fig. 5.7: TS101 connection (example)

## 5.4 Adjustment

### 5.4.1 Factory setup

See below for the automatic tare and store unit's factory setup:

Tare unit: Tare value will not be stored upon power failure

Low-pass filter active (0.4 Hz ... 12.5 Hz)

Amplification  $v=1$

Store unit: Peak-value store (maximum value) on

Low-pass filter off

Amplification  $v=1$

Envelope curve off

### 5.4.2 Tare unit adjustment

Taring is started when the voltage level on terminal 10 changes over from 0 V to 24 V (positive edge). The tare value is held during voltage supply, even if the voltage level goes down to 0 V again (also refer to next chapter).



#### NOTE

**Taring with input voltages greater than  $\pm 10.5$  V is not possible due to amplifier overflow. A valid tare value ( $<10.5$  V) is signalled by an LED on the board and the "High" voltage level on terminal 6.**

- **Save tare value and protect it from power failure**

The tare value can be stored for reuse after a power failure or after power-off. For this, set switch S100/6 to "ON" position before taring.

Switch	Switch position	Effect
S100/6	OFF	Tare value will be lost upon power-off *)
	ON	Tare value will be permanently stored in EEPROM

\*) Factory setup

- **Signal amplification**

The net signal can be amplified to obtain a sufficiently high resolution even with measurement tasks with great initial load. Use switch S101 to adjust the amplification in four steps:

S101/2	S101/3	S101/4	S101/5	Amplification
ON	OFF	OFF	OFF	v=1
OFF	ON	OFF	OFF	v=2
OFF	OFF	ON	OFF	v=5
OFF	OFF	OFF	ON	v=10

### Example

A load cell with 10 kg nominal load is used with an initial load of 4 kg. The mass to be weighed is 1 kg.

To avoid amplifier overload the amplifier's measuring range must be adjusted to maximum signal (here 5 kg=10 V output voltage). The automatic tare unit connected in series is used to tare the initial load (4 kg=8 V). The remaining residual signal of 1 kg corresponds to an output voltage of 2 V. Subsequent amplification by factor 5 enables the residual signal to be raised to 10 V.

- **Low-pass filter adjustment**

Use switch S100/5 to activate the filter for the automatic tare unit, only, or also for the peak-value store. Upon taring, the low-pass filter influences the input signal. However, it has no effect on the tare output's bandwidth.

S100/5	Position P1 (cutoff frequency)	Influences
OFF		tare unit
ON		tare <b>and</b> store unit

**Tab. 5.2:** Low-pass filter

## Procedure

- Set switch S100/7 to "OFF" position
- To activate the filter for the peak value as well, set switch S100/5 to "ON" position
- Push and hold switch S6 and turn potentiometer P1. Refer to Tab. 5.2 for the cutoff frequency and the appropriate potentiometer position.



### NOTE

The filter frequencies for taring and peak value always bear a constant relationship and cannot be adjusted independently of each other.

### 5.4.3 Store unit adjustment

- **Adjust operating mode**

Use the signal levels on terminals 8 and 9 to select the operating mode (current value/peak value) and the Run/Hold function.

Terminal	Level	Function	Effect
8	High	Run	Store contents is permanently kept up to date
	Low	Hold	Store contents is held
9	High	Peak	Peak value operating-mode
	Low	Reset	Current value operating-mode

High=24 V; Low=0 V



### NOTE

The peak-value store is cleared by switching from the peak value operating-mode to current value.

- **Select peak value and amplification**

Use the switches S100/1... 4 and S101/1 to define the type of peak value to be stored (min/max, peak-peak) and the amplification.

S101/1	S100/1	S100/2	S100/3	S100/4	Function
ON	OFF	OFF	OFF	OFF	Peak value minimum
ON	ON	OFF	OFF	OFF	Peak value maximum <sup>*)</sup>
ON	OFF	ON	OFF	OFF	Peak-to-peak
ON	ON	ON	OFF	OFF	(Peak-to-peak) x 0.5
ON	OFF	OFF	ON	OFF	Tared minimum value (v=1)
ON	ON	OFF	ON	OFF	Tared maximum value (v=1)
ON	OFF	ON	ON	OFF	Tared minimum value (v=2)
ON	ON	ON	ON	OFF	Tared maximum value (v=2)
ON	OFF	OFF	OFF	ON	Tared minimum value (v=5)
ON	ON	OFF	OFF	ON	Tared maximum value (v=5)
ON	OFF	ON	OFF	ON	Tared minimum value (v=10)
ON	ON	ON	OFF	ON	Tared maximum value (v=10)
OFF	OFF	OFF	ON	ON	Minimum value (peak-value output) <b>and</b> maximum value (tare output)

**Tab. 5.3:** Adjust peak value and amplification

<sup>\*)</sup> Factory setup



## NOTE

**With the minimum and maximum value setup selected, no taring is possible due to the fact that the tare output is used for output of the maximum value. Please make sure that for the maximum value (tare output) amplification v=1 has been adjusted (switches S101/2...5, see page 37).**

- **Adjust envelope curve**

Use switch S100/7 and potentiometer P1 to adjust the envelope curve operating-mode.

### Procedure:

- First make sure that the "Peak value" operating mode has been adjusted (see page 38).
- Make sure that the type of peak value to be stored has been adjusted (see Tab. 5.3).
- Set switch S100/7 to "ON" position.
- Push and hold switch S6 and turn potentiometer P1.

Refer to Tab. 5.4 for the discharge rate and the appropriate potentiometer position. For more precise acquisition of the change in discharge rate use an oscilloscope.

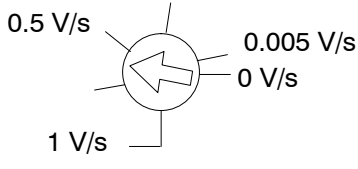
Switch S100/7	P1	Envelope-curve function
ON	At right-hand stop	Off
ON	Turn anticlockwise from right-hand stop	Discharge rate 0.005...1 V/s 
OFF	No effect	Off

**Tab. 5.4:** Envelope-curve adjustment

- **Low-pass filter**

It is possible to filter the peak-value store's input signal. Refer to Tab. 5.2, page 37 for the required setups. Please remember that the filter frequencies cannot be adjusted independently of each other because they bear a constant relationship.

## 5.5 Zero-point balance

A zero-point balance has been made at the factory. Should the output signals for tare unit and store unit vary from zero, it is possible to correct them. Use switches S100/1... 4 and S101/1 to define the output to be corrected.

S101/1	S100/1	S100/2	S100/3	S100/4	Function
ON	ON	OFF	ON	ON	Tare output (terminal 5)
ON	OFF	ON	ON	ON	Peak-value output (terminal 4)

### Procedure

- Push and hold key S6.
- Use potentiometer P1 to adjust the zero point.

Should the balancing range available not be sufficient:

- Release key S6.
- Turn potentiometer to initial position.
- Restart the balancing procedure.



## 5.6 Component position diagram

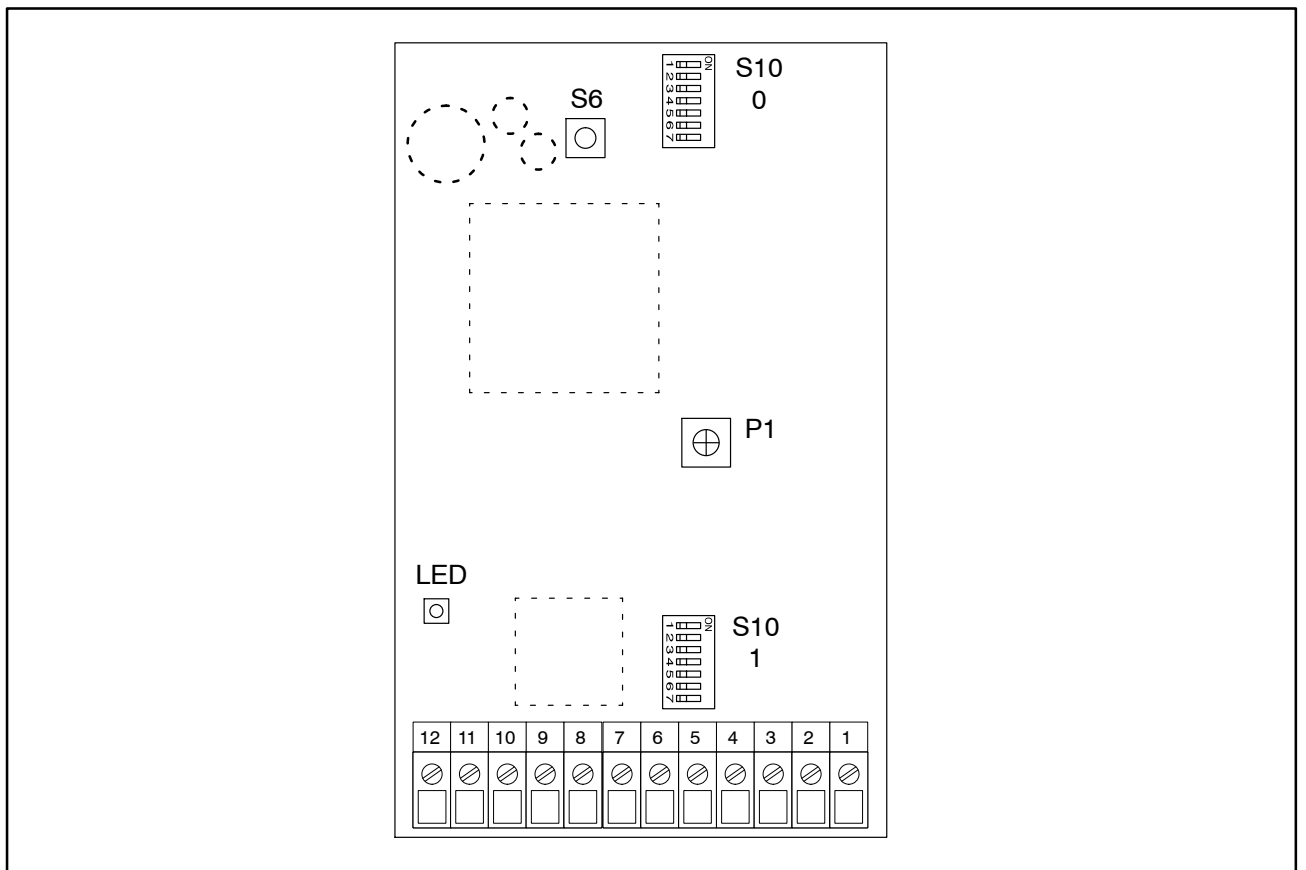

**Fig. 5.8:** TS101 tare and store unit

## 6 Safety barriers

Connect HBM safety barriers to obtain intrinsically safe measuring circuits [EEx ia] IIC. A test certificate is required for transducers used in such applications.

Measuring amplifier	Safety barrier
AE101	SD01A
AE301	SD01A

Due to the safety barriers' high internal resistance, the bridge excitation voltage  $V_E$  must be reduced according to the transducer resistance  $R_B$  or the transducer inductance  $L_B$  respectively. Refer to the below table to obtain the minimum permissible transducer resistance.

Measuring amplifier	$V_E$	$R_{B(\text{minimum})}^*)$ , $L_B$
<b>AE101</b>	10 V	not permissible
	5 V	320 $\Omega$
	2.5 V	130 $\Omega$
<b>AE301</b>	5 V	320 $\Omega$
	2.5 V	130 $\Omega$

\*) With longer cables the supply-line resistance must be added.

## 7 CLIP IG

For use in industrial environments, the CLIP modules can be installed in an aluminium-die-cast wall housing. The degree of protection is IP65. The housing enables max. 4 modules incl. power supply unit to be inserted; it is also possible to insert two measuring amplifiers with safety barriers.

The wall-housing version is particularly suitable for rough environments. It is protected from electromagnetic interference in the surroundings.

The CLIP IG devices are mounted at the factory and wired internally.

All combinations are available on request.

Attached to CLIP IG devices accessory bags 2-9278.0339 are delivered including a standard set of earthing bushes, end sleeves for strands (0.5 mm<sup>2</sup>, 10mm long) and non-buckling bushes that fit HBM cables of type

KAB8/00-2/2/2 (6 x 0.14 mm<sup>2</sup>) or

Order No. 4-3301.0082, blue (6 x 0.14 mm<sup>2</sup>) or

4-3301.0071, gray (6 x 0.14 mm<sup>2</sup>)

## 8 Dimensions

AE101  
AE301  
AE501  
EM201  
EM201K2  
GR201  
TS101

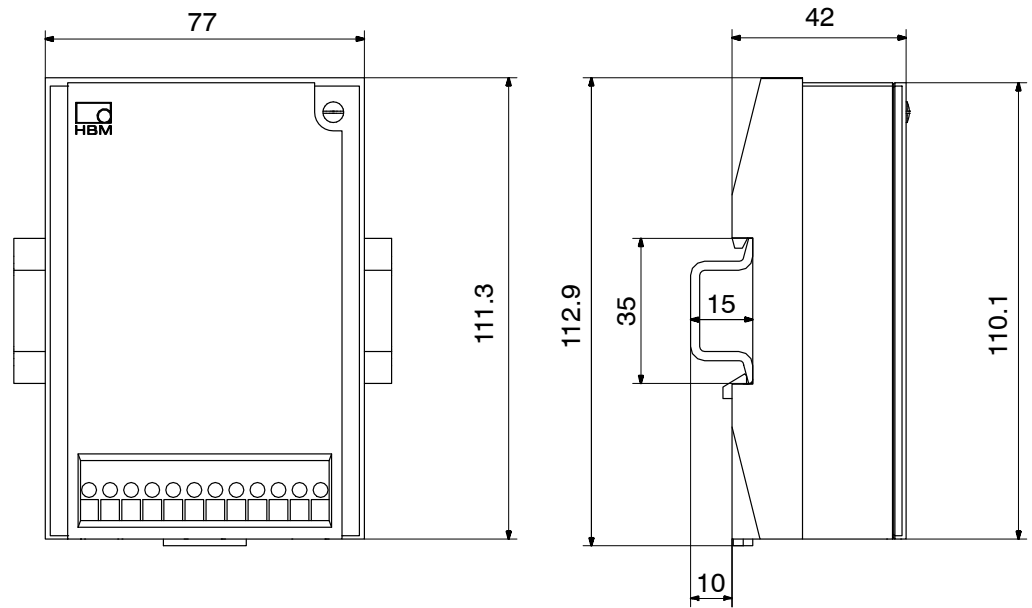

NT101A  
NT102A

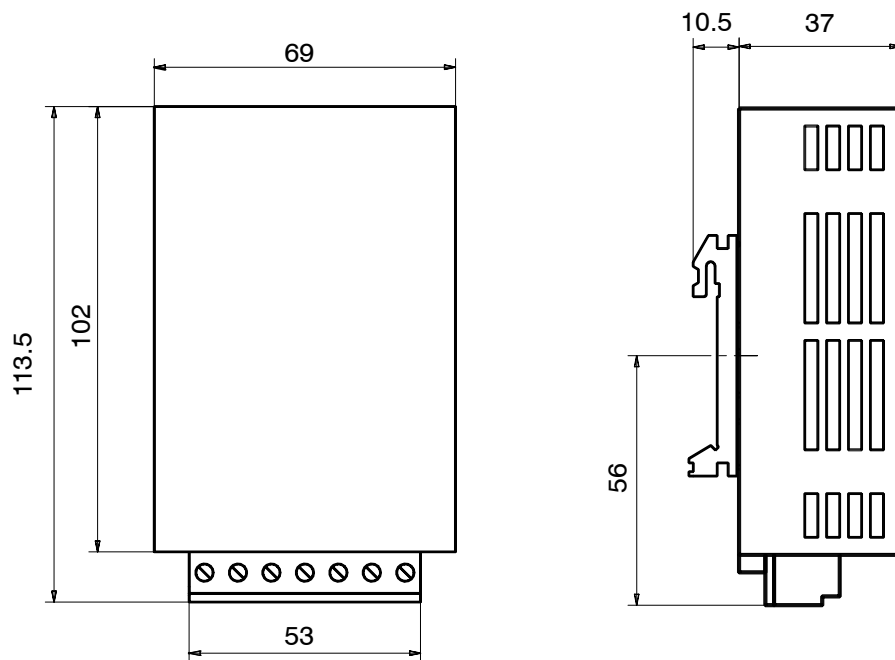

Clip IG

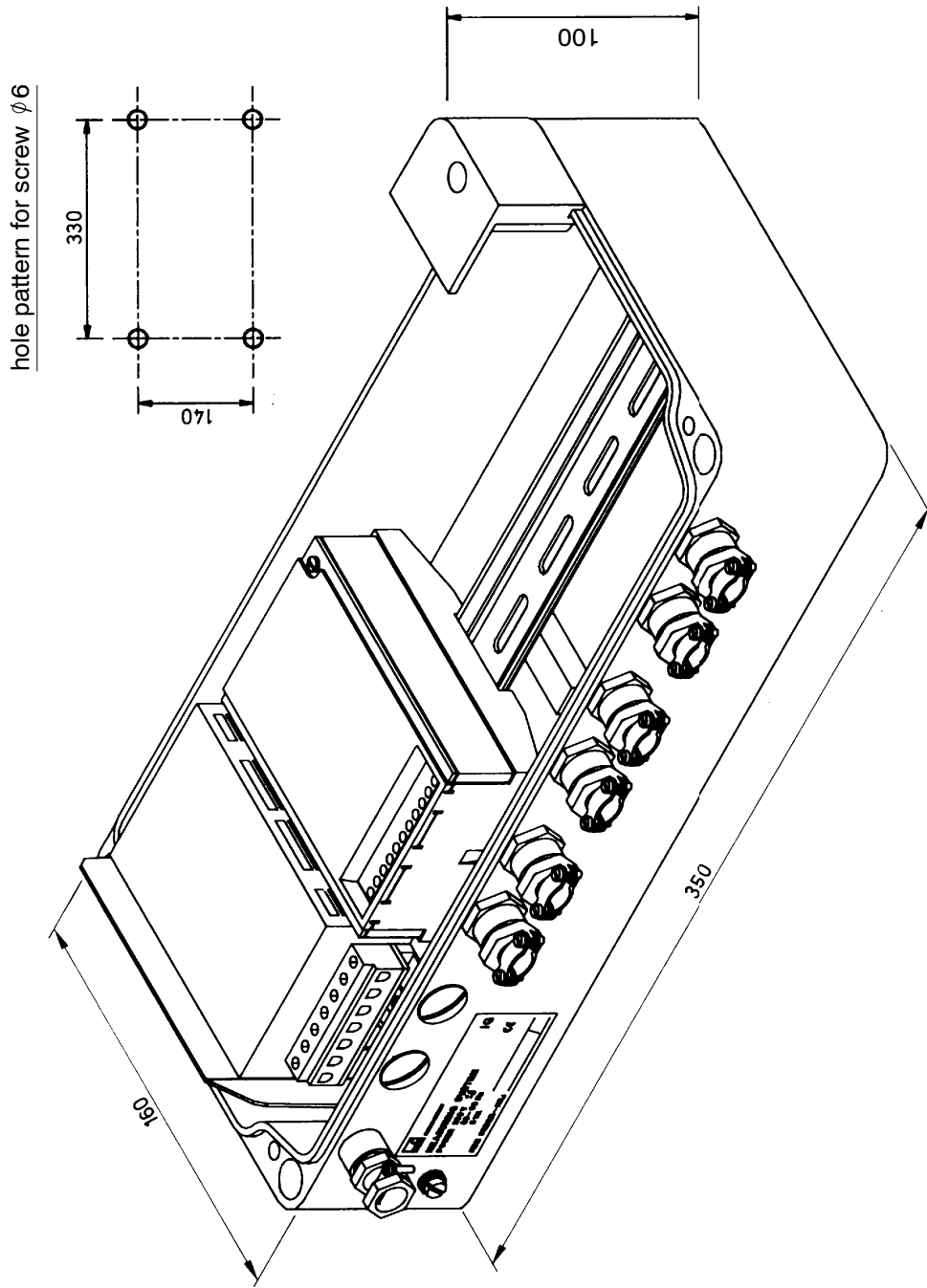

Weight of housing: 3.2kg







©Hottinger Baldwin Messtechnik GmbH.  
Subject to modifications.  
All product descriptions are for general information only.  
They are not to be understood as a guarantee of quality or durability.

**Hottinger Baldwin Messtechnik GmbH**

Im Tiefen See 45 • 64293 Darmstadt • Germany

Tel. +49 6151 803-0 • Fax: +49 6151 803-9100

Email: [info@hbm.com](mailto:info@hbm.com) • [www.hbm.com](http://www.hbm.com)

**measure and predict with confidence**

