

P3TCP / P3MBP

Ultra-high pressure transducers for up to 15,000 bar



Special features

- For static and dynamic pressure variance, pressure peaks and pressure fluctuations
- Principle of measurement: foil strain gage
- Monolithic design, measuring body has no welded seam
- High number of load cycles

Top Class

- Better temperature response
- Individually documented values
- Improved accuracy class
- Closer sensitivity tolerance (suitable for parallel connection, for differential pressure measurement, for example)

Dimensions (in mm; 1 mm = 0.03937 inches)

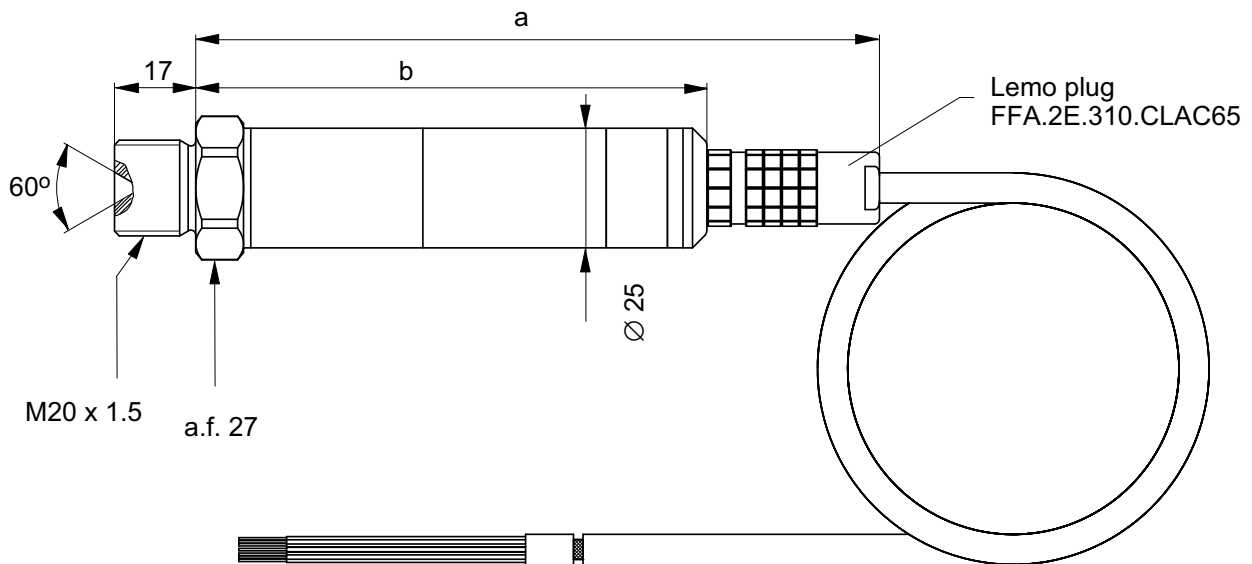

Connection cable
 1-Kab 170-3; 3 m
 1-Kab 170-7; 7 m
 (as an option)

	a	b
P3MBP BlueLine	143	107
P3 Top Class BlueLine	132	96

Specifications P3MBP BlueLine per DIN 16086

Type	P3MBP BlueLine			
Mechanical input quantities				
Pressure type	absolute pressure			
Principle of measurement	foil strain gage			
Measuring range, 0 bar...	bar	5000	10000	15000
Accuracy class¹⁾		0.3	0.5	0.75
Output characteristics				
Nominal (rated) sensitivity	mV/V	1		
Sensitivity tolerance	%	< ± 0.3	< ± 0.6	< ± 0.8
Effect of temperature on zero signal in the nominal (rated) excitation voltage range per 10K, rel. to nominal (rated) sensitivity				
	in the nominal (rated) temperature range	%	± 0.1	± 0.2
	in the operating temperature range	%	± 0.15	± 0.25
Effect of temperature on sensitivity in the nominal (rated) excitation voltage range per 10K, rel. to actual value				
	in the nominal (rated) temperature range	%	± 0.1	± 0.2
	in the operating temperature range	%	± 0.3	± 0.4
Characteristic curve deviation (setting of initial point)	%	0.3	0.5	0.75
Repeatability per DIN 1319	%	< ± 0.05		

1) Accuracy class is not a DIN 16086 concept. The figure conforms to the maximum single deviation; that is the characteristic curve deviation (setting of initial point) and deviations as a result of temperature, related to a difference of 10 K.

Test report P3MBP BlueLine



Prüfprotokoll
test certificate / protocole d'essai

Typ: P3MBP / Blue Line	Auftrag: 80114172	
<small>Type / type</small>	<small>order no / commission</small>	
Nennmessbereich: 5000 bar	Prüfer: Kozacki	
<small>nominal range</small>	<small>examined / controller</small>	
Ident-Nr.: 143310284	Datum: 2010-09-30	
<small>serial no / N° ident</small>	<small>test date / date of essay</small>	

Prüfergebnisse:
test results / résultats d'essai

Eingangsgröße des Messbereichs [%] <small>input quantity / étendue d'essai</small>	Ausgangsgröße [mV/V] <small>output quantity / résultats</small>
0	0.0000
50	0.4981
100	1.0006
50	0.4993
0	0.0001

Die Prüfergebnisse über 3000 Bar sind extrapolierte Werte. Der maximale Prüfdruck beträgt 3000 Bar.
The test results exceeding 3000 Bar are extrapolated values. The maximum pressure for testing amounts to 3000 Bar.
Les résultats d'essai supérieurs à 3000 Bar sont des valeurs extrapolées. La pression maximale d'essai est de 3000 Bar.

Aus den Prüfergebnissen berechnete und sonstige messtechnische Eigenschaften:
technical characteristics calculated from the repeating results and others
valeurs caractéristiques calculées à partir des résultats d'essai

Kennwert C [mV/V] <small>sensitivity / sensibilité</small>	1.0006
Kennlinienabweichung, Anfangspunkteinstellung [%vC] <small>combined error / erreur combinée</small>	0.150
Relative Umkehrspanne [%vC] <small>relative hysteresis / hystérésis relatif</small>	0.124

Allgemeine Zusatzinformationen:
general information / informations complémentaires

Alle weiteren messtechnischen Eigenschaften des Aufnehmers sind durch Typprüfungen und laufende Produktkontrollen des Qualitätswesens abgesichert.
All other metrological characteristics of the transducer are verified by type testing and regular product audits of the quality assurance.
Toutes les autres caractéristiques techniques du capteur sont garanties par le Service Qualité, au moyen d'essais et d'audits réguliers de produit.

Zertifiziert nach ISO 9001 und ISO14001 (DQS-09001) Akkreditiertes DKD Kalibrierlaboratorium und EMV-Prüflaboratorium
ISO 9001 and ISO 14001 certified / Certification selon ISO 9001 and ISO 14001 Accredited DKD Calibration Laboratory and EMC Testing Laboratory
Laboratoire accrédité par le DKD en matière d'essais CEM
DKD-K-00101; D-PL-12026-01

Höttinger Baldwin Messtechnik GmbH Im Tiefen See 46 D-64293 Darmstadt
Ausgabe 10/04, Version 0 233.00.1000P
02.01.2011 14047 KPS16

Information on the linearity of the individual transducer

Information on the sensitivity, characteristic curve deviation and rel. reversibility error of the individual transducer.

Specifications P3 Top Class BlueLine per DIN 16086

		P3 Top Class BlueLine		
Mechanical input quantities				
Pressure type		absolute pressure		
Principle of measurement		foil strain gage		
Measuring range, 0 bar...	bar	5000	10000	15000
Accuracy class¹⁾		0.25	0.4	0.6
Output characteristics				
Nominal (rated) sensitivity	mV/V	1		
Sensitivity tolerance	%	< ± 0.2	< ± 0.4	< ± 0.8
Zero signal tolerance	%	< ± 1		
Creep upon unloading 15 min	%	< ± 0.03		
Effect of temperature on zero signal in the nominal (rated) excitation voltage range per 10K, rel. to nominal (rated) sensitivity				
in the nominal (rated) temperature range	%	± 0.05		
in the operating temperature range	%	± 0.10		
Effect of temperature on sensitivity in the nominal (rated) excitation voltage range per 10K, rel. to actual value				
in the nominal (rated) temperature range over 0 °C	%	± 0.05		
in the nominal (rated) temperature range below 0 °C	%	± 0.1		
in the operating temperature range	%	± 0.2		
Characteristic curve deviation (setting of initial point)	%	0.25	0.4	0.6
Rel. interpolation error (max. deviation of a cubic interpolation function over the test series)	%	0.05	0.25	-
Long-term stability of zero signal and span (data per year)	%	0.2		
Repeatability per DIN 1319	%	< ± 0.05		

1) Accuracy class is not a DIN 16086 concept. The figure conforms to the maximum single deviation; that is the characteristic curve deviation (setting of initial point) and deviations as a result of temperature, related to a difference of 10 K.

Extended test report

Page 1

Test report P3 Top Class BlueLine

Page 2

Information on the linearity of the individual transducer

Information on the sensitivity, characteristic curve deviation and rel. reversibility error of the individual transducer.

Information on the max. interpolation error as a % and the coefficient of the cubic compensation function in the form $X = R \cdot Y^3 + S \cdot Y^2 + T \cdot Y$ of the individual transducer

Information on the temperature dependency of the individual transducer

Information on the temperature coefficient of the zero signal and on the temperature coefficient of the output span of the individual transducer.

The following data applies to P3MBP BlueLine and P3 Top Class BlueLine

Mechanical input quantities				
Measuring range, 0 bar...	bar	5000	10000	15000
Initial value	bar	0		
Operating range at reference temperature	%	120	110	
Overload limit at reference temperature	%	120	110	
Test pressure	%	195	150	100
Dynamic loading				
Permissible pressure	%	100		
Permissible oscillation width to achieve a typical 10,000,000 DIN 50100 load cycles	bar	3500	5000	6000
Dead volume with supplied packing ²⁾	mm ³	615	150	100
	mm ³	200	-	-
Control volume	mm ³	approx. 1		
Output characteristics				
Fundamental resonance frequency	kHz	> 100		
Input resistance at reference temperature	Ω	350 ±5		
Output resistance at reference temperature	Ω	350 ±5		
Insulation resistance	MΩ	5000		
Electrical strength	V	90		
Excitation voltage				
Reference excitation voltage	V	5		
Nominal (rated) excitation voltage	V	0.5 ... 7.5		
Operating range	V	0.5 ... 12		
Ambient conditions				
Permissible voltage between measuring circuit and transducer ground at reference temperature	V	50		
Materials for parts which come into contact with the environment (type-dependent)		1.4301; 1.4541; 1.4542; 1.4548; 1.6354 PU / chrome-plated and nickel-plated brass		
Reference temperature	°C	+23		
Nominal (rated) temperature range	°C	-10...+80		
Operating temperature range	°C	-40...+100		
Storage temperature range	°C	-40...+100		
Impact resistance (tested to DIN 40 046)				
Impact acceleration	m/s ²	1000		
Impact duration	ms	4		
Impact form		Half sine wave		
Acceleration sensitivity per 10 m/s ² for exciting frequencies of < 20% of natural frequency	%	< ± 0.001		
Mechanical specifications				
Pressure connection		M20 x 1.5 with 60° inner cone for use with 56° double cone		
Electrical connection		Lemo connector ERA.2E.310.SLL		
Bending radius of the connection cable, min.	static	mm	35	
	dynamic	mm	75	
Mounting position		any		
Weight without cable, approx.	g	200		
Degree of protection		IP67		

2) Packing is only used for the 5000 bar measuring range

Economical, standard versions available from stock:

Measuring range, 0 bar...	Pressure type	Product number
P3MBP BlueLine		
5,000 bar	absolute pressure	1-P3MBP/5,000 BAR
10,000 bar	absolute pressure	1-P3MBP/10,000 BAR
15,000 bar	absolute pressure	1-P3MBP/15,000 BAR
P3 Top Class BlueLine		
5,000 bar	absolute pressure	1-P3TCP/5,000 BAR
10,000 bar	absolute pressure	1-P3TCP/10,000 BAR
15,000 bar	absolute pressure	1-P3TCP/15,000 BAR

Pin assignment P3MBP BlueLine

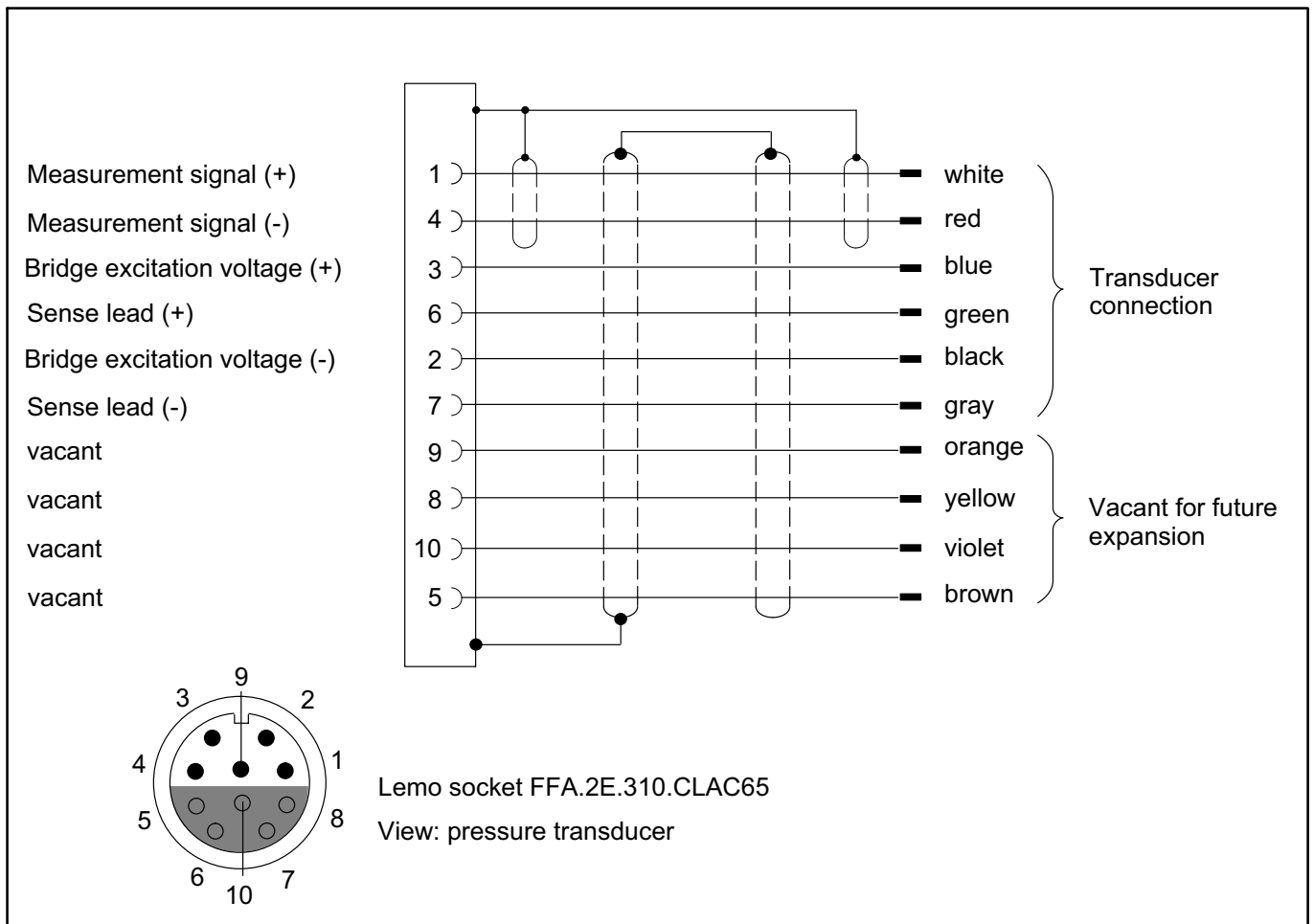

Pin assignment P3 Top Class BlueLine

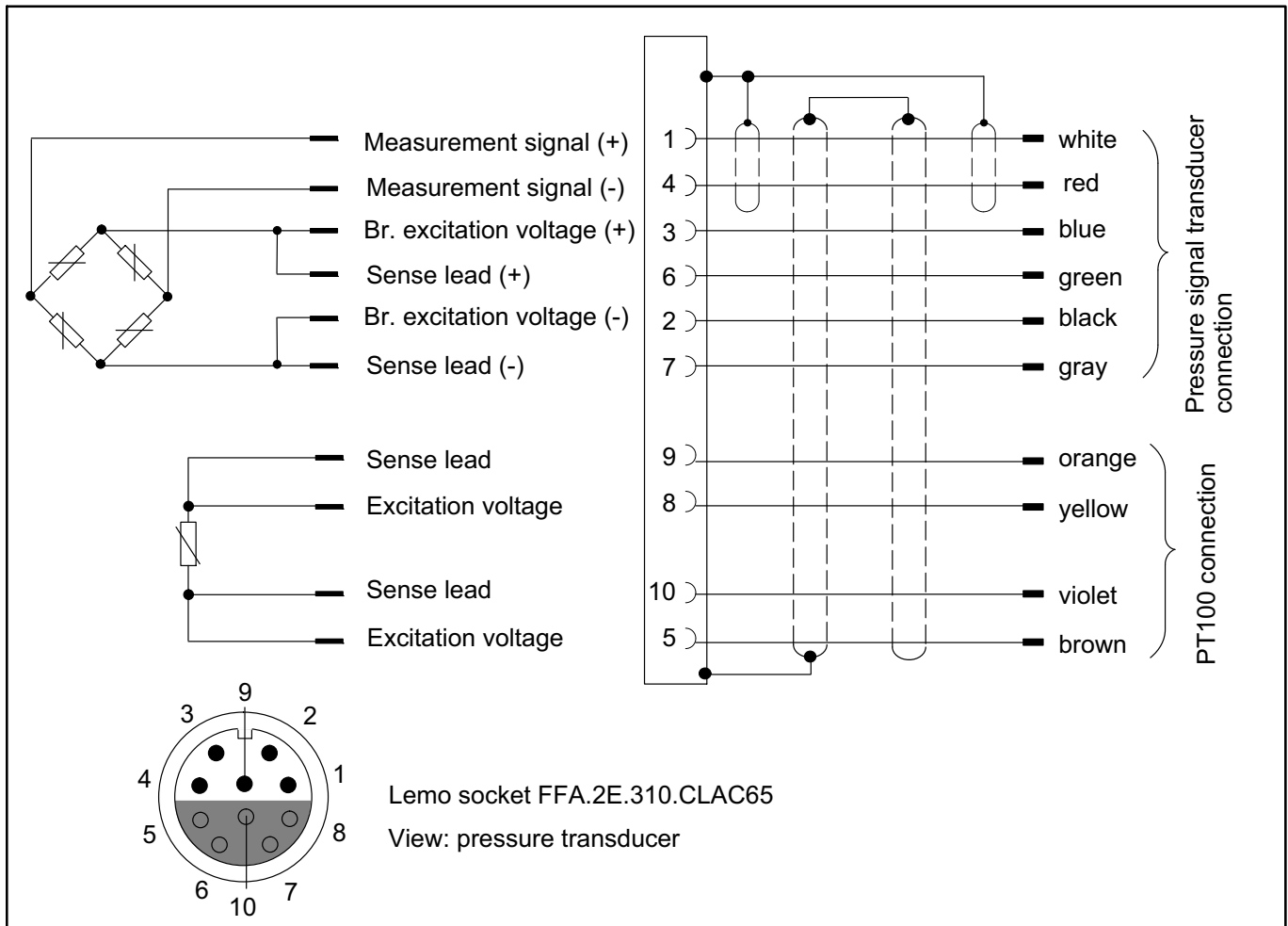

Accessories

Included in scope of supply:

- For 5,000 bar: 2 double-cone seals
- For 10,000 bar and 15,000 bar: 2 double-cone seals incl. locking spring

Seal accessories:

- 5,000 bar: 2-9278.0372 bag, conical seal P3MB/5000 bar
- 10,000 bar: 2-9278.0373 bag, conical seal P3MB/10000 bar
- 15,000 bar: 2-9278.0375 bag, conical seal P3MB/15000 bar

Pressure transducer mounting

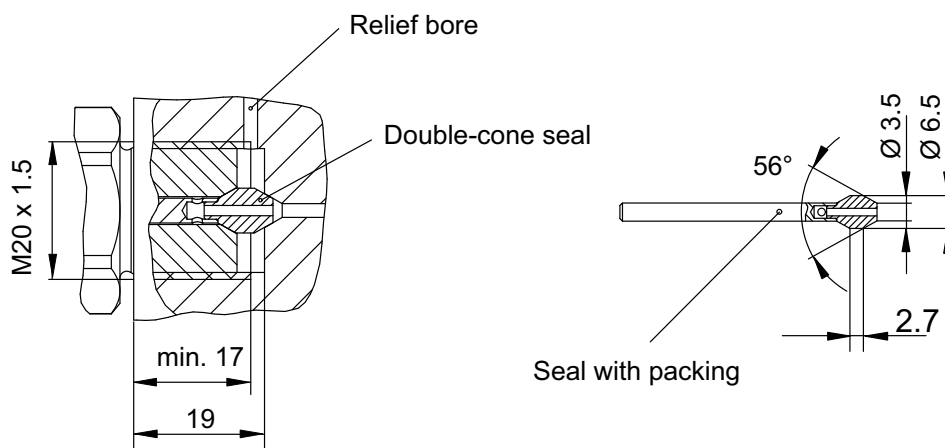

P3MBP 5000 bar

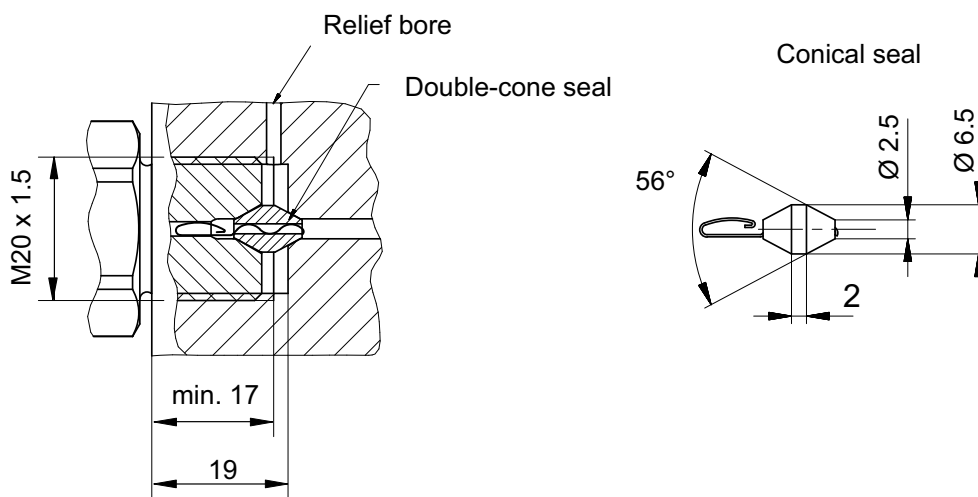

P3MBP 10000 bar and P3MBP 15000 bar

Subject to modifications.
All product descriptions are for general information
only. They are not to be understood as a guarantee
of quality or durability.

Hottinger Baldwin Messtechnik GmbH
Im Tiefen See 45 · 64293 Darmstadt · Germany
Tel. +49 6151 803-0 · Fax +49 6151 803-9100
Email: info@hbm.com · www.hbm.com

measure and predict with confidence

