

# GEN series

## GEN5i

### Portable Data Recorder

#### Special features

- PC integrated mainframe
- Robust and portable
- Five slots for acquisition cards
- Accepts any mix of GEN DAQ acquisition cards
- Up to 160 analog channels
- 50 MB/s continuous streaming rate
- 100 MB/s continuous streaming rate using SSD disk options
- Remote use from external PC
- Perception Enterprise software for advanced review and analysis

The GEN5i is a robust portable transient recorder and data acquisition system and part of the proven GEN DAQ series data acquisition systems. The GEN5i comes with a Core 2 Duo Intel CPU, 4 GB of memory, large, high-resolution TFT screen, full dual monitor support, Windows® 7 Ultimate 64 Bit and Perception Enterprise software for performance based analysis, computing and reporting. The GEN5i has Windows® 7 pre-installed with five different languages; Perception comes with these five plus three more languages pre-installed.

To maximize storage speed, the GEN5i uses a RAID 0 drive setup to guarantee 50 MB/s sustained continuous recording speed. Using solid state disk options increases this speed to 100 MB/s. For more reliable storage the GEN5i supports different storage options ranging from internal RAID 0 solid state disk to replacement of the internal fixed system disk with a fully removable RAID 0 hard disk or solid state disk. Using one of the removable system disk options guarantees enhanced data security, since no classified data will be left behind when the removable system disk has been taken out of the GEN5i.

# GEN5i Block Diagram

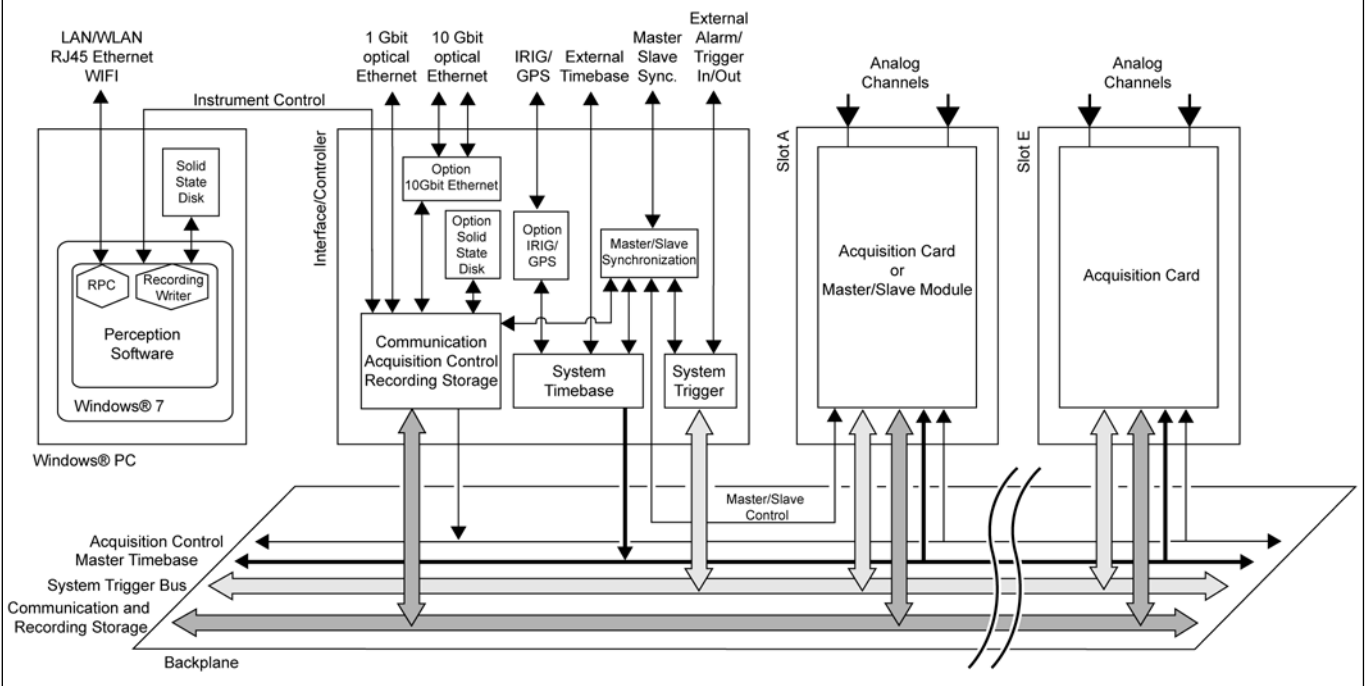

# Windows® PC Block Diagram

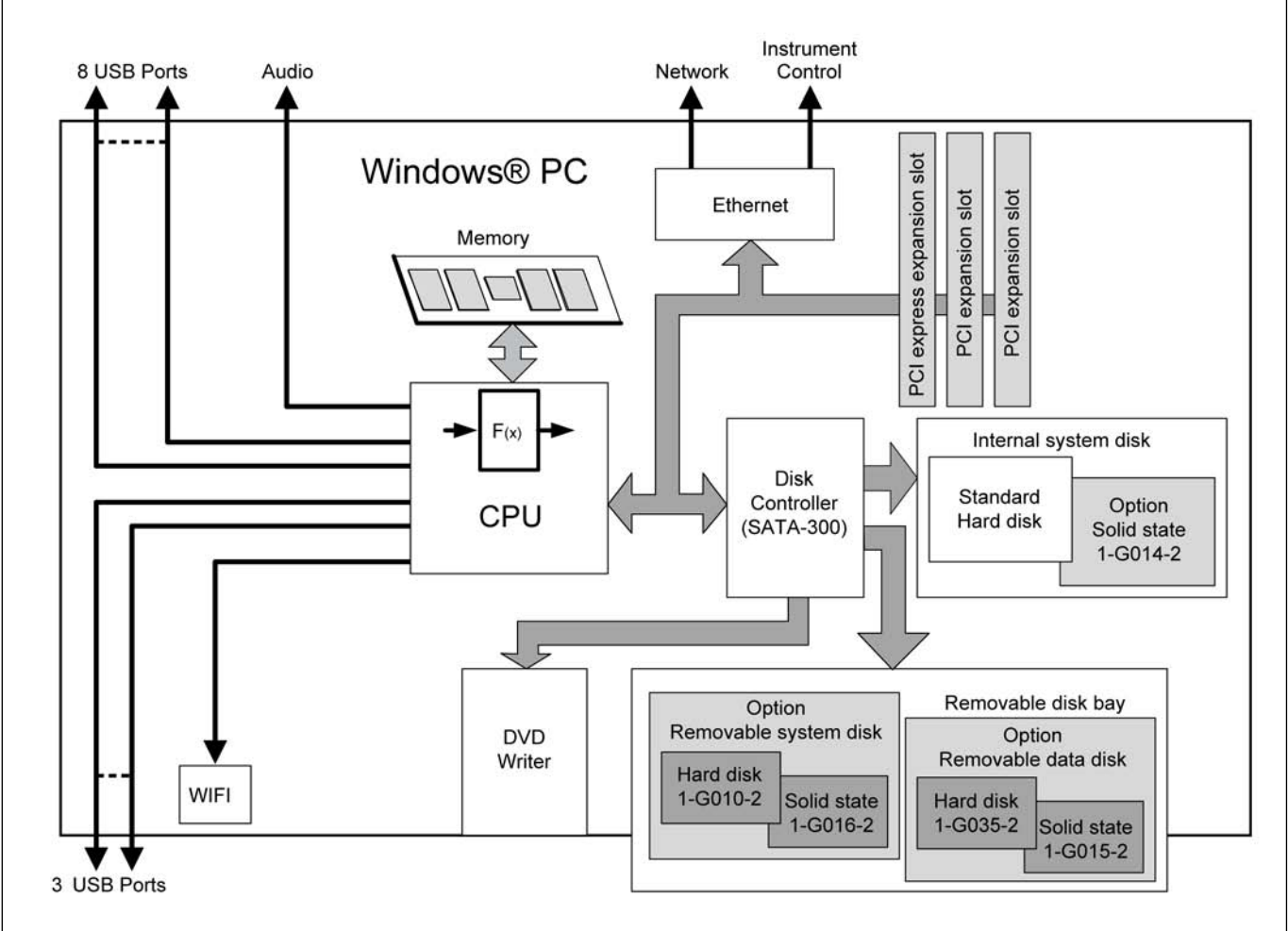

<b>Windows® PC</b>	
Memory	DDR2 RAM; 4 GB
Processor	Intel Core 2 Duo Desktop E6400, Conroe, 2.13 GHz, 2 MB Cache
Ethernet	RJ45 Ethernet connection; 1 Gbit/s
Instrument Control	RJ45 Ethernet connection dedicated for GEN DAQ communication only. (Access covered by protective housing). Fixed IP address 172.16.10.1
Wireless LAN	Embedded 801.11b/g/n; 54, 100 and 300 Mbit/s <sup>(1)</sup>
USB Connectors	USB 2.0, 8 on back + 3 on front
Internal Storage PC disk	SATA-300; RAID 0 (striping, no redundancy) hard disk 1.5 TB <sup>(2)</sup>
CD/DVD drive	DVD-R/+R (4.7 GB) Read/Write, DVD-R/+R DL (8.5 GB) Read/Write, DVD-RW/+RW (4.7 GB) Read/Write, CD-R/RW Read/Write, CD/DVD-ROM Read
Display	TFT SXGA screen, 17" / 1280x1024 resolution, 16.7 M colors
Video connection	CRT 2048 x 1536 and DVI-D 1600 x 1200
Multiple Monitors Support	Clone mode and extended mode
Speaker/Line Out	Internal speaker/jack plug 3.5 mm
Microphone	Jack plug 3.5 mm
Accessories	USB Keyboard and USB optical mouse TFT protective cover with storage for keyboard and mouse
Expansion cards	2; Full height, half length PCI slots 1; Full height, half length PCIe 4x slot
Front panel buttons	5 recording control buttons; Start/Stop/Pause/Trigger/Single shot

- (1) GEN5i systems shipped before August 2012, only support 801.11b/g; 54 Mbit/s.  
(2) GEN5i systems shipped before August 2011, are built with smaller drive configurations.

<b>Disk Option Overview</b>							
Disk option	System/data disk	Hard disk/solid state	Removable	Factory installed	RAID 0 striping	Size unformatted	Continuous write speed
Standard	System	HDD	No	Yes	Yes	1.5 TB	50 MB/s
1-G014-2	System	SSD	No	Yes	Yes	600 GB	100 MB/s <sup>(1)</sup>
1-G010-2	System	HDD	Yes	Yes	Yes	640 GB	40 MB/s <sup>(2)</sup>
1-G016-2	System	SSD	Yes	Yes	Yes	600 GB	100 MB/s <sup>(1)</sup>
1-G035-2	Data	HDD	Yes	No	No	320 GB	25 MB/s <sup>(3)</sup>
1-G015-2	Data	SSD	Yes	No	No	300 GB	100 MB/s <sup>(1)</sup>
<b>Combination Overview</b>							
Disk option	Standard system disk	1-G014-2	1-G010-2	1-G016-2	1-G035-2	1-G015-2	
1-G014-2	✗	✗	✗	✗	✓	✓	
1-G010-2	✗	✗	✗	✗	✗	✗	
1-G016-2	✗	✗	✗	✗	✗	✗	
1-G035-2 <sup>(4)</sup>	✓	✓	✗	✗	✓	✓	
1-G015-2 <sup>(4)</sup>	✓	✓	✗	✗	✓	✓	

- (1) Speed limited by Instrument Control transfer speed; Max 50 MB/s for systems shipped before January 2012.  
(2) Speed limited by removable 2.5" RAID 0 hard disk.  
(3) Speed limited by removable 2.5" single hard disk.  
(4) Multiple data disks can be ordered, but only used one at the time.

<b>Software</b>	
DAQ software	Perception Enterprise package. Refer to Perception specification sheet for details.
DAQ Software and Instrument panel languages	English, German, French, Chinese, Japanese, Korean, Russian, Portuguese (Brazilian)
Operating system	Microsoft Windows® 7 Ultimate 64 Bit version
Operating system installed languages	English, German, French, Chinese, Japanese Other languages can be downloaded and installed using "Windows® Update"

<b>Application Programmers Interfaces (API)</b>	
<b>PNRF reader (free of charge)</b>	
Functions	Read PNRF, NRF and LRF recording files directly in your own application
COM Interface	The PNRF reader comes as COM interface and can be used from any application or programming language which supports COM automation
PNRF Software Development Kit (SDK)	Installs PNRF dll's and supplies Visual Basic, C# and C++ getting started examples
Matlab Integration	Matlab PNRF reader install and example available within the PNRF SDK
LabVIEW Integration	Available directly from National Instruments
<b>DCE/RPC (Distributed Computing Environment/Remote Procedure Calls)</b>	
Functions	Control Perception software from an external computer/application on Windows®, Linux, Unix, Mac OS X
COM Interface	All RPC commands have a COM wrapper for easier Windows® software integration
Available Basic Commands	Load and Save Perception setup files, Setup Recording, set and review Hardware Settings, Start/Stop/Pause/Trigger, monitor Live data
Examples (free of charge)	C++ and C# getting started example programs supplied for Windows®, source code included. Unsupported Linux getting started example on request only.
LabVIEW Integration (free of charge)	LabVIEW getting started example using RPC/COM available
<b>CSI (Customer Software Interface)</b>	
Functions	Create software extension inside the Perception software by adding CSI user sheets, custom automation and extended analyses functions. Basic Windows C# sheet template included. Available for all Microsoft .NET® 4 supporting languages.
Available Basic Controls & Commands	Access to every Perception part: Start/Stop/Pause and Trigger, Start Manager, Acquisition System, Hardware Settings, Displays, Meters, User Tables, Formulas, Calculations, Data Manager, Data Sources, User variables, Notifications, Logging, Conversion Functions, Automation Actions, Sheet Manager and more, to create a dedicated application GUI that hides the entire Perception standard GUI
Examples (Free of charge)	C# getting started example programs supplied, source code included
<b>Training/Support Program</b>	
HBM offers paid professional training and support programs on all API interfaces (PNRF reader, RPC and CSI). Training program will be C# based, on-site or at central HBM location. On-site training can be customer specific. Support can be the development of a full custom software application or answering questions of software engineers.	

<b>Acquisition System</b>	
<b>Interface/Controller Module</b> Standard integrated in every GEN5i mainframe; creates central time base and synchronization	
<b>Acquisition Slots</b> Unused slots must be covered using the GEN DAQ blank panel. This closes the mainframe front panels for EMC/EMI and safety compliance but also regulates the internal airflow for correct cooling of the acquisition system.	
Maximum slots	5
Acquisition boards	All slots support any combination of GEN DAQ Acquisition boards
Master/Slave board	Master/Slave board supported in Slot A only.
Digital Event/Timer/Counter connector	0
Thermal control	Every acquisition board and the Interface/Controller module monitors its own temperatures and status. This is used to regulate FAN speeds and reduce noise while optimizing airflow and power consumption.
Calibration	Any changes to the Acquisition system configuration, may change its internal thermal gradients. As accurate calibration relies on a steady and repeatable thermal environment, calibration will be void if changes are made in the configuration.

<b>Power</b>	
Power Inlet	47-63 Hz, 90-264 V AC
Total Power of unit (maximum)	500 VA

## IM2 Interface/Controller Module

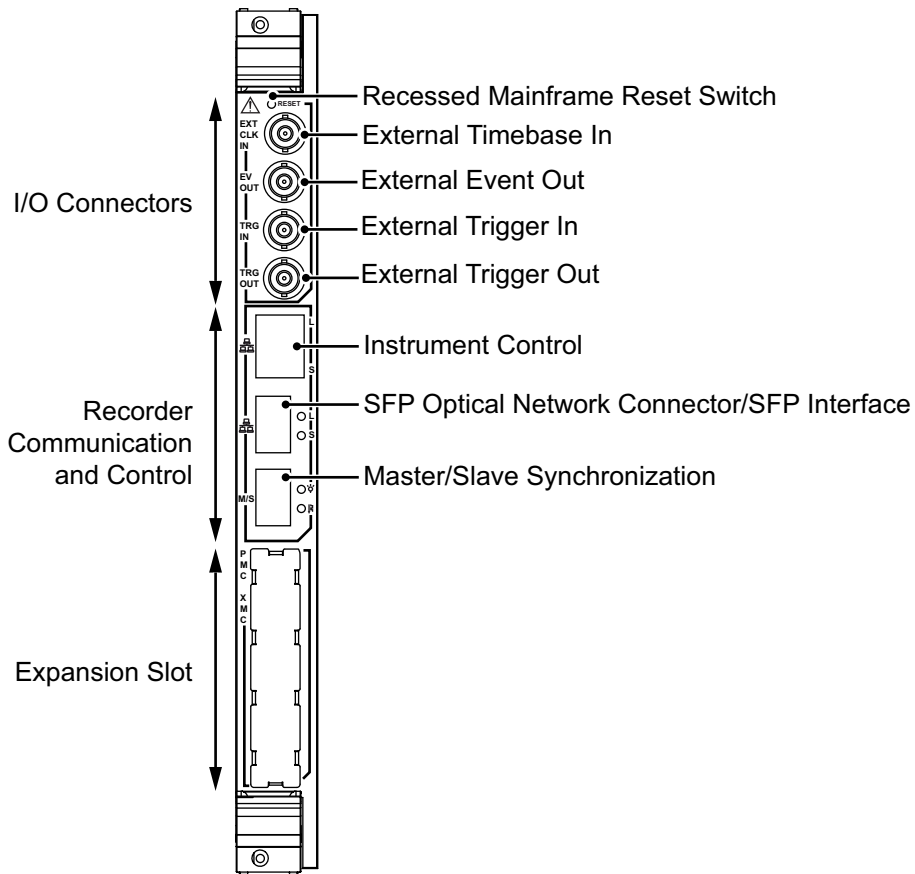

Systems shipped before January 2012, are equipped with IM1 Interface/Controller Module.

## Recorder Communication and Control

### Network Interface

Instrument Control	1 Gbit/s, Ethernet (use fixed TCP/IP address: 172.16.5.1, access covered by protective housing)
Optional 1 Gbit/s Ethernet, optical	1 Gbit/s, optical SFP module using LC connector 850 nm optical wavelength, MultiMode fiber cable, 500 m maximum length or 1310 nm optical wavelength, SingleMode fiber cable, 10 km maximum length. Uses dedicated SFP interface
Optional 10 Gbit/s Ethernet, optical	Maximum 2 interfaces of 10 Gbit/s optical SFP+ modules using LC connectors 850 nm optical wavelength, MultiMode fiber cable, 66 m maximum length or 1310 nm optical wavelength, SingleMode fiber cable, 10 km maximum length Uses the XMC/PMC expansion slot

### TCP/IP

Protocol	IPv4
Address setup	DHCP/Auto IP or fixed IP
DHCP setup	When DHCP fails Auto IP setup is used similar to Windows® PCs
Gateway setup	Gateway setup supported for control through VPN and/or Internet

### Maximum Transfer Speed

Instrument Control	50 MB/s; 100 MB/s using solid state disk options <sup>(1)</sup>
1 Gbit/s network to a remote PC	100 MB/s <sup>(1)(3)</sup>
10 Gbit/s network to a remote PC	200 MB/s <sup>(1)(3)</sup>

## Recorder Communication and Control

CPU and Software	
CPU	ATOM based
Operating System	Linux <sup>(2)</sup>

- (1) Tested using several combinations of acquisition modules.
- (2) Linux GPL open source code can be downloaded from HBM website.
- (3) Tested using Windows® 7 PC using Intel i7 CPU and SSD RAID drive with write speeds exceeding 700 MB/s sustained.

## Timebase and Master/Slave Synchronization

Central Timebase <sup>(1)</sup>	
Accuracy	± 3.5 ppm; aging after 10 years ± 10 ppm <sup>(2)</sup>
Clock base	Binary, Decimal or External
Master/Slave Synchronization	Supported by the optional Master/Slave card Master/Slave Synchronization connector only supported by GEN2i mainframes

- (1) The Interface/Controller module provides a central timebase for all acquisition cards.
- (2) Systems shipped before January 2012: ± 30 ppm.

## I/O Connectors

External Timebase In	TTL compatible
Pulse width	100 ns min.
Maximum frequency	5 MHz
Active edge	Rising
Rounding resolution	4.01 µs; 250 kS/s and 20 kS/s acquisition cards
	1.01 µs; 1 MS/s and 200 kS/s acquisition cards
	510 ns; 2 MS/s and 200 kS/s (GN611) acquisition cards
	60 ns; 100 MS/s and 25 MS/s acquisition cards
Input to sample moment delay	350 – 400 ns, plus maximum 1 full "rounding resolution"
Input overvoltage protection	± 30 V DC
External Trigger In	TTL compatible
Resolution	50 ns
Minimum pulse width	500 ns
Active edge	Selectable rising or falling
Input overvoltage protection	± 30 V DC
Delay <sup>(1)</sup>	± 1 µs + maximum 1 sample period (for decimal and binary time base)
Send to External Trigger Out	User can select to forward External Trigger In to the External Trigger Out BNC
Top Dead Center Rotational input	Used to indicate top dead center in rotational external timebase
External Trigger Out	TTL compatible
Active level	Selectable High/Low/Hold High
Pulse width	High or Low selected: 12.8 µs Hold High selected : Active from first trigger to end of recording
Output impedance	50 Ω
Short circuit protected	Continuous
Delay <sup>(1)</sup>	516 ± 1 µs + maximum 1 sample period when Clock base: decimal, Filter: wideband <sup>(2)</sup>
	504 ± 1 µs + maximum 1 sample period when Clock base: binary, Filter: wideband <sup>(2)</sup>

<b>I/O Connectors</b>	
External Event Out	TTL compatible
Function	Selectable Alarm or Recording Active output
Active level	Selectable High/Low for Alarm output Recording active High output
Pulse width	Alarm: Active from start of alarm condition until condition ends Recording: Active until recording stops
Output impedance	50 $\Omega$
Short circuit protected	Continuous
Delay <sup>(1)</sup>	515 $\pm$ 1 $\mu$ s + maximum 1 sample period when Clock base: decimal, Filter: wideband <sup>(2)</sup>
	503 $\pm$ 1 $\mu$ s + maximum 1 sample period when Clock base: binary, Filter: wideband <sup>(2)</sup>

(1) Delays are equal for all acquisition cards.

(2) If analog and/or digital filter is used extra delay will be added depending on type of filter and signal frequency.

<b>Local Storage options<sup>(1)</sup></b>	
<b>Solid State Disk<sup>(2)</sup></b> Built inside the GEN DAQ series mainframes to optimally secure data storage. Recorded data can be copied to permanent archive using Perception software.	
Size	300 GByte
Maximum continuous storage speed	50 MB/s <sup>(3)</sup> , limited by PNRF recording file management on the Interface/Controller module
Maximum sweep storage speed	Depends on sweep length and number of channels used
File system	Linux EXT4
Connection	SATA-300
Location	Built-in on interface module, not removable
Disk	Only HBM qualified disks are supported
<b>iSCSI Storage</b> Ethernet based SCSI connections to external disks supporting iSCSI; Supports external NAS disks (Network Attached Storage). Embedded Linux from GEN Series Interface/Controller Module directly reads and writes data to the iSCSI disk.	
Protocols used	RFC 3720 iSCSI initiator, RFC 3721 naming and discovery
Name format structure	iqn.yyyy-mm.domain:device.ID
Optional authorization	CHAP, username and password negotiation
Maximum continuous storage speed	40 MB/s <sup>(3)(4)</sup> , limited by PNRF recording file management and iSCSI software overhead on the Interface/Controller Module
Maximum sweep storage speed	Depends on sweep length and number of channels used
File system	Linux EXT4 (not directly readable by Windows <sup>®</sup> without using 3 <sup>rd</sup> party tools). Recorded data can be read by Perception using a GEN DAQ mainframe connected to the iSCSI drive or any Linux system connected to the iSCSI drive using a SAMBA server.
Disk partition size	Maximum 2 TB disk volume
GEN DAQ series access	Exclusive iSCSI access required
Windows <sup>®</sup> access	Create network share by using Linux SAMBA server

(1) Not supported by Instrument panel software. Can only be used in standard Perception software.

(2) Denotes an option that requires factory installation.

(3) Tested using several combinations of acquisition cards.

(4) Appropriate NAS server required to keep up with maximum data rate.

Tested using Synology<sup>®</sup> DS212+ and RS3412 using 1 Gbit/s or 10 Gbit/s Ethernet links.

<b>Expansion Slot options (1 slot available)</b>	
IRIG	IRIG A and B, AM modulated or DCLS (DC level shifted)
IRIG/GPS	IRIG A and B, AM modulated or DCLS (DC level shifted) GPS, comes with GPS antenna and 15 m (590") GPS cable (used for time synchronization only)
10 Gbit/s Ethernet	Maximum 2 interfaces of 10 Gbit/s SFP+ modules using LC connectors

## Physical, Weight and Dimensions

Weight	
Mainframe (Maximum including cover)	20 kg (44 lbs), add ≈ 1 kg (2.2 lbs) per acquisition board installed
Dimensions	
Height	339 mm (13.4")
Width/Width including handle	443 mm/493 mm (17.4"/19.4")
Depth/Depth including handle/cover	358 mm/498 mm (14.1"/19.6")
Temperature Sensors	Temperature monitoring and air flow control
Cooling Fans	4
Handle	One carrying handle, also used for higher tilt angles
Tilting Feet	Two retractable feet for small tilt angles
Grounding	Mains and 4 mm Banana plug
Casing	Aluminum/Plastic cover
Soft carry case	Option to be ordered separately; carry case with storage pouches for mouse, keyboard and accessories

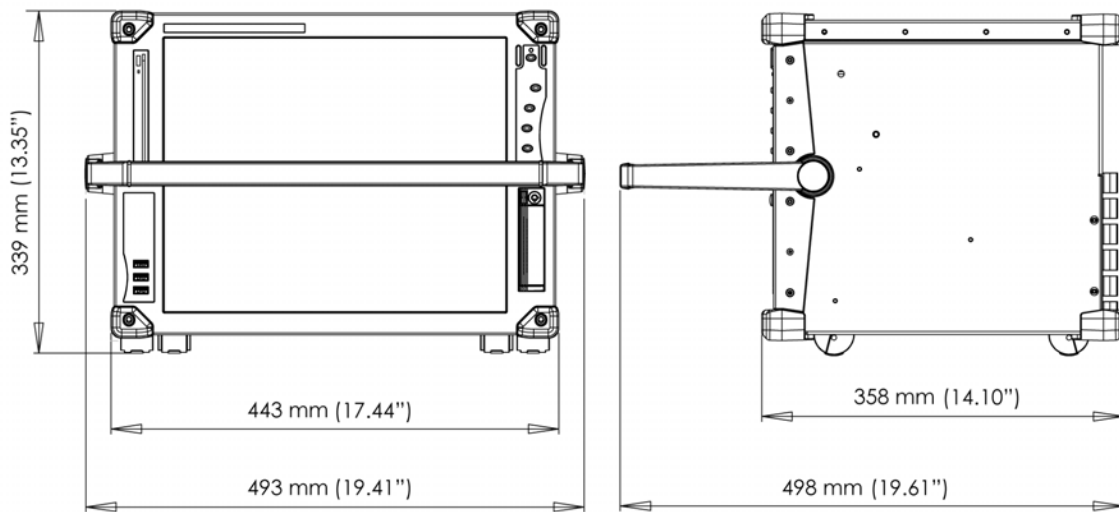

Figure 1.1: Dimensions GEN5i (without cover)

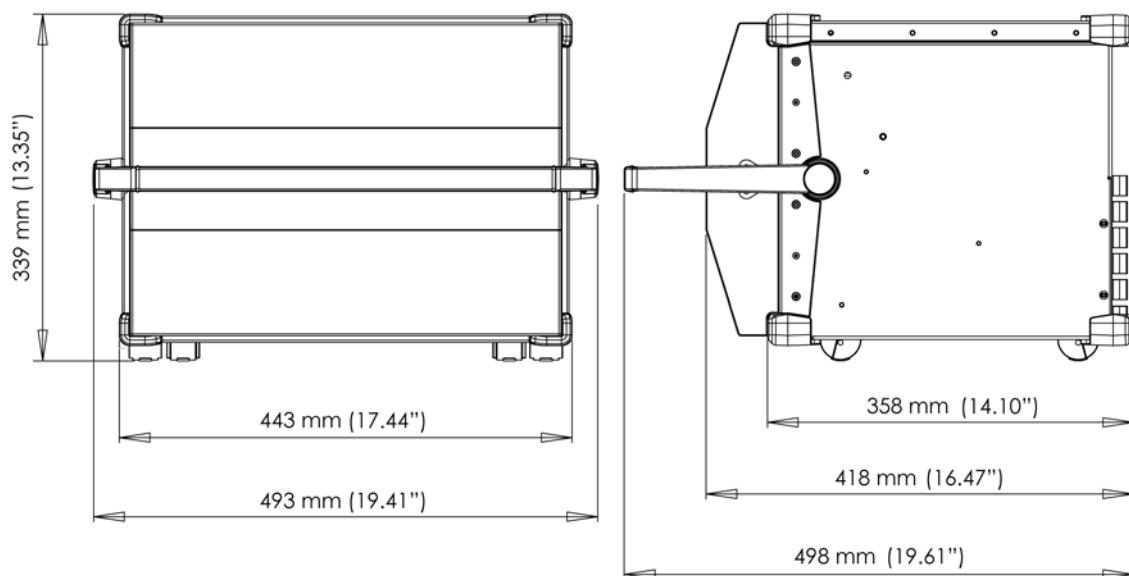

Figure 1.2: Dimensions GEN5i (with cover)

<b>Environmental Specifications</b>	
Temperature Range	
Operational	0 °C to +40 °C (+32 °F to +104 °F)
Non-operational (Storage)	-25 °C to +70 °C (-13 °F to +158 °F)
Thermal protection	Automatic thermal shutdown at 85 °C (+185 °F) internal temperature User warning notifications at 75 °C (+167 °F) (Supported by Perception V6.30 or higher)
Relative humidity	0 % to 80 %; non-condensing; operational
Protection class	IP20
Altitude	Maximum 2000 m (6562 feet); operational
Shock: IEC 60068-2-27	
Operational	Half-sine 10 g/11 ms; 3-axis, 1000 shocks in positive and negative direction
Non-operational	Half-sine 25 g/6 ms; 3-axis, 3 shocks in positive and negative direction
Vibration: IEC 60068-2-34	
Operational	1 g RMS, ½ h; 3-axis, random 5 to 500 Hz
Non-operational	2 g RMS, 1 h; 3-axis, random 5 to 500 Hz
Operational Environmental Tests	
Cold test IEC60068-2-1 Test Ad	-5 °C (+23 °F) for 2 hours
Dry heat test IEC-60068-2-2 Test Bd	+40 °C (+104 °F) for 2 hours
Damp heat test IEC60068-2-3 Test Ca	+40 °C (+104 °F), humidity >93 % RH for 4 days
Non-Operational (Storage) Environmental Tests	
Cold test IEC-60068-2-1 Test Ab	-25 °C (-13 °F) for 72 hours
Dry heat test IEC-60068-2-2 Test Bb	+70 °C (+158 °F) humidity <50 % RH for 96 hours
Change of temperature test IEC60068-2-14 Test Na	-25 °C to +70 °C (-13 °F to +158 °F) 5 cycles, rate 2 to 3 minutes, dwell time 3 hours
Damp heat cyclic test IEC60068-2-30 Test Db variant 1	+25 °C/+40 °C (+77 °F/+104 °F), humidity >95/90 % RH 6 Cycles, cycle duration 24 hours

<b>Harmonized Standards for CE Compliance, according to the following directives</b>	
Low voltage directive (LVD): 2006/95/EC	
Electromagnetic compatibility directive (EMC): 2004/108/EC	
<b>Electrical Safety</b>	
EN 61010-1 (2010)	Safety requirements for electrical equipment for measurement, control, and laboratory use - General requirements
EN 61010-2-030 (2010)	Particular requirements for testing and measuring circuits
<b>Electromagnetic Compatibility</b>	
EN 61326-1 (2006)	Electrical equipment for measurement, control and laboratory use - EMC requirements - Part 1: General requirements
<b>EMISSION</b>	
EN 55011	Industrial, scientific and medical equipment - Radio-frequency disturbance characteristics - Limits and methods of measurement Conducted disturbance: class B; Radiated disturbance: class A
EN 61000-3-2	Limits for harmonic current emissions: class D
EN 61000-3-3	Limitation of voltage changes, voltage fluctuations and flicker in public low-voltage supply systems
<b>IMMUNITY</b>	
EN 61000-4-2	Electrostatic discharge immunity test (ESD); contact discharge ± 4 kV/air discharge ± 8 kV: performance criteria B
EN 61000-4-3	Radiated, radio-frequency, electromagnetic field immunity test; 80 to 2700 MHz using 10 V/m, 1000 Hz AM: performance criteria A
EN 61000-4-4	Electrical fast transient/burst immunity test Mains ± 2 kV using coupling network. Channel ± 2 kV using capacitive clamp: performance criteria B
EN 61000-4-5	Surge immunity test Mains ± 0.5 kV/± 1 kV Line-Line and ± 0.5 kV/± 1 kV/± 2 kV Line-earth Channel ± 0.5 kV/ ± 1 kV using coupling network: performance criteria B

## Harmonized Standards for CE Compliance, according to the following directives

Low voltage directive (LVD): 2006/95/EC

Electromagnetic compatibility directive (EMC): 2004/108/EC

EN 61000-4-6	Immunity to conducted disturbances, induced by radio-frequency fields 0.15 to 80 MHz, 1000 Hz AM; mains - 10 Vrms, using clamp; channel - 3 Vrms, using clamp: performance criteria A
EN 61000-4-11	Voltage dips, short interruptions and voltage variations immunity tests Dips: performance criteria A; Interruptions: performance criteria C

## IRIG, IRIG/GPS (options, to be ordered separately)

### IRIG<sup>(1)</sup>

Supported by IRIG and IRG/GPS option

#### Time Code Translator (Input)

Time Code formats	IRIG A and IRIG B, IEEE 1344 compliant AM Modulated or DC level shift (DCLS)
Modulation ratio	3:1 to 6:1
Input amplitude	500 mV to 5 V Peak-to-Peak
Input impedance	>10 k $\Omega$

#### Time Code Output

Time Code format	IRIG B, IEEE 1344 compliant
Modulation ratio	3:1
Output amplitude	4 V Peak-to-Peak (fixed) into 50 $\Omega$
DC level shift	TTL/CMOS
AM modulated input/output connectors	2 SMB sockets; one for input and one for output
DCLS connector	Micro DP, 15-pin; some signals internally linked to Interface/Controller Module
Time synchronization accuracy	<5 $\mu$ s modulated, <1 $\mu$ s (DCLS)
GEN DAQ series functions	Capture start of recording time Synchronize Master Time Base oscillator frequency

#### Time required to full synchronization after IRIG signal detected

No recording active	1 to 5 minutes
Recording or pause active	1 to 5 minutes plus 25 s per ms recording time deviation from IRIG time
User notifications while recording	Time marks on IRIG signal lost/restored and IRIG time synchronized
Short term tracking stability	5.0 E-8
Long term tracking "Fly-wheeling"	5.0 E-7

### GPS<sup>(1)</sup>

Only supported by IRG/GPS option

GPS connector	Micro DP, 9-pin
GPS antenna	1; included
GPS antenna cable	50 m (164 feet); included
Time synchronization accuracy	<1 $\mu$ s
GEN DAQ series functions	Capture start of recording time Synchronize Master Time Base oscillator frequency
GPS localization time	2 to 15 minutes

#### Time required to full synchronization after GPS localization completed

No recording active	1 to 10 minutes
Recording or pause active	1 to 10 minutes plus 25 s per ms recording time deviation from IRIG time
User notifications while recording	Time marks on GPS satellites lost/restored and GPS time synchronized
Short term tracking stability	5.0 E-8
Long term tracking "Fly-wheeling"	5.0 E-7

(1) Requires factory installation

### Master/Slave Card (option, to be ordered separately)

Maximum number of mainframes	9; one Master controlling up to eight Slaves
LED signaling	Optical link synchronized, not connected, function disabled
Connection topology	Star connection; each Slave directly connected to Master by individual cables
Cable type	850 nm Multi Mode (50/125 $\mu$ m) optical cable (single 3 m (10 feet) cable included)
Maximum cable length	500 m (1640 feet)
Cable length delay compensation	Automatic delay compensation supported
Time required to full synchronization after Master/Slave signal detected	
No recording active	1 to 5 minutes
Recording or pause active	1 to 5 minutes plus 25 s per ms recording time deviation from Master time
User notifications while recording	Time marks on Master/Slave signal lost/restored and Master/Slave time synchronized
Basic Synchronization	
First sample	Synchronizes the first sample in the recording for each mainframe
Synchronized timebase	Prevents frequency drift of the sample rates within each mainframe
Channel trigger exchange	Synchronously exchanges every channel trigger connected to the Master/Slave trigger bus to/from each connected mainframe
Mainframe to mainframe phase shift	$\pm$ 100 ns
Extended Synchronization <sup>(1)</sup>	
Synchronous recording actions	Not supported by Master/Slave card
Synchronous manual trigger	Not supported by Master/Slave card

(1) Extended Synchronization only supported by GEN2i Master/Slave Synchronization connector.

### GEN5i Shipping Case (option, to be ordered separately)

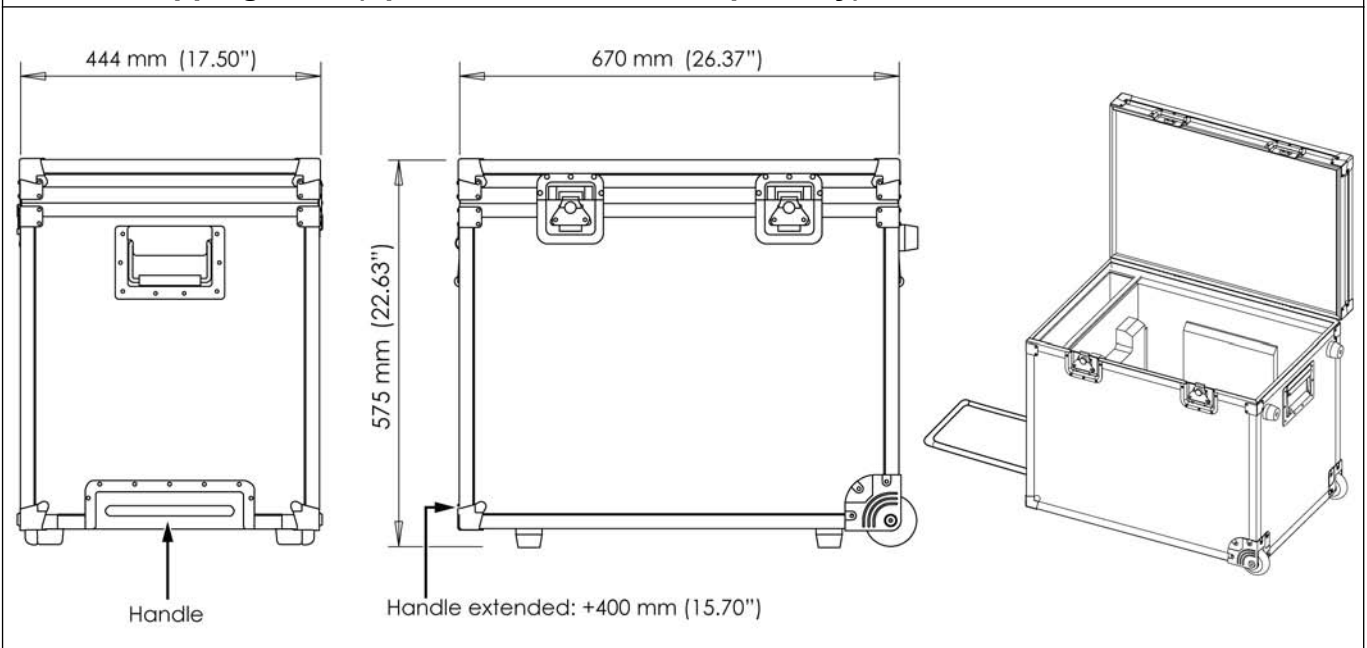

**Figure 1.3:** Hardcover reusable shipment case with wheels and transport handle

Dimensions	575 mm (22.63") x 444 mm (17.50") x 670 mm (26.37") (H x W x D)
Weight Empty Case	20.3 kg (44.75 lbs)
GEN5i Storage Area	Special area for GEN5i, slides in from the top for easy storage and removal from the shipment case. Protects the GEN5i TFT for impact during drop, shock and vibrations
GEN5i Accessories Area	Separate area for GEN5i keyboard, mouse, power cable and some cables
Reliable Case Transport	Wheels and extendable handle constructed for stable transportation with low gravitation point to avoid tumbling of case in any direction during roll transport
Case Extras	Two lift handles and locks on side of the case for easy transport
Shock and Vibration	Tested with GEN5i inside case according to ASTM D4728 E
Drop Test	Tested with GEN5i inside case according to ASTM D4169-04 Level I

**GEN5i Rack Mount Kit (option, to be ordered separately)**

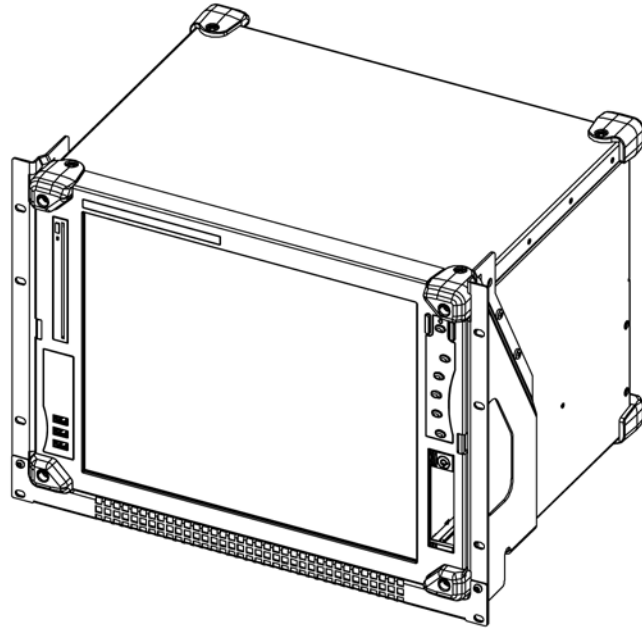

**Figure 1.4:** GEN5i with installed 19-inch brackets

GEN5i Rack Mount Kit

Mounting GEN5i mainframe in a standard 19" rack. Does not support the mouse and keyboard delivered with the GEN5i. Requires no additional mounting materials. User installed option.

## Acquisition Cards

Model	Type	Isolation	Max. SR <sup>(1)</sup>	Resolution	Memory <sup>(2)</sup>	Channels	Event, T/C <sup>(3)</sup>
Basic200k	Single Ended	no	200 kS/s	16 bit	128 MB	8	0, 0
Basic200k XT ISO	Unbalanced Differential	yes	200 kS/s	16 bit	128 MB	8	0, 0
Basic1M	Single Ended	no	1 MS/s	16 bit	256 MB	8	0, 0
Basic1M ISO	Unbalanced Differential	yes	1 MS/s	16 bit	512 MB	8	0, 0
Basic1M XT ISO	Unbalanced Differential	yes	1 MS/s	16 bit	512 MB	8	0, 0
Bridge200k ISO	Bridge/Differential	yes	200 kS/s	16 bit	128 MB	4	0, 0
Bridge1M ISO	Bridge/Differential	yes	1 MS/s	16 bit	512 MB	4	0, 0
Uni200k ISO	Differential/IEPE/Shunt	yes	200 kS/s	16 bit	128 MB	4	0, 0
Uni1M ISO	Differential/IEPE/Shunt	yes	1 MS/s	16 bit	512 MB	4	0, 0
Basic20k-16	Differential	no	20 kS/s	16 bit	200 MB	16	16, 0
Basic20k-32	Differential	no	20 kS/s	16 bit	200 MB	32	16, 0
HiRes250k-16	Differential/IEPE/Charge	no	250 kS/s	16/24 bit	1800 MB	16	16, 2
HiRes250k-32	Differential/IEPE/Charge	no	250 kS/s	16/24 bit	1800 MB	32	16, 2
HiSpeed 25M	Differential/Single Ended	no	25 MS/s	15 bit	128 MB	4	0, 0
HiSpeed 100M	Differential/Single Ended	no	100 MS/s	14 bit	1800 MB	4	0, 0
Fiber100M 6600	Optical Fiber	yes	100 MS/s	...(4)	1800 MB	4(4)	0, 0
Fiber100M 7600	Optical Fiber	yes	100 MS/s	...(4)	1800 MB	4(4)	0, 0
Iso1kV200k	Balanced Differential	yes	200 kS/s	16/18 bit	200 MB	6	16, 2
Iso1kV2M	Balanced Differential	yes	2 MS/s	16/18 bit	1800 MB	6	16, 2
Marker1M	Binary	no	1 MS/s	1 bit	512 MB	64	0, 0
Marker1M HV	Optical/Binary	yes & no	1 MS/s	1 bit	512 MB	8 & 32	0, 0

(1) Maximum Sample Rate/channel (not multiplexed).

(2) Total recording memory/card.

(3) Digital Events, Timer/Counter channels (Supported by GEN2i Digital Event/Timer/Counter connector only).

(4) This card supports maximum four optical fiber transmitter channels.

## Optical Fiber Transmitter Channels

### Transmitter

Every transmitter is a single channel unit. Every unit has an unbalanced differential input, amplifier, analog anti alias filter and ADC with an optical data and control link to the receiver card. The receiver card has the recording logic, sample rate selection and memory.

Model	Receiver Card	Power	Sample rate	Resolution	Isolation
HV6600 100M	Fiber100M 6600	Battery	100 MS/s	14 bit	User application defined
HV6600 25M	Fiber100M 6600	Battery	25 MS/s	15 bit	User application defined
MV6600 100M	Fiber100M 6600	120/240 V AC	100 MS/s	14 bit	1800 V RMS
MV6600 25M	Fiber100M 6600	120/240 V AC	25 MS/s	15 bit	1800 V RMS
7600 100M	Fiber100M 7600	External 12 V DC	100 MS/s	14 bit	User application defined

## Special Function Cards

5B Carrier

Uses one GEN DAQ slot, holds up to six 5B modules. 5B modules, I/O connectors and cabling not included. An acquisition card is required for actual recording.  
The 5B Series signal conditioning modules provide a low cost method of connecting analog signals with data acquisition systems. They are designed to convert thermocouples, RTD's, strain gages, frequencies, potentiometers, slide wires and other signals into standardized, isolated analog outputs.

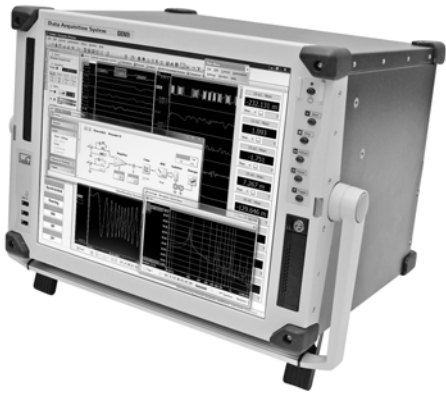
Ordering Information <sup>(1)</sup>		
Article	Description	Order No.
GEN5i	 <p>GEN5i rugged, portable data recorder.<sup>(2)</sup> Integrated Instrument, with five acquisitions slots, 50 MB/s streaming rate, integrated PC, Windows® 7 Ultimate, 17 inch TFT, 1.5 TB RAID disk, Mouse, Keyboard, protective front cover with integrated mouse and keyboard storage. Includes Perception Enterprise software package.</p>	1-GEN5i-2

(1) All GEN series systems are intended for exclusive professional and industrial use.

(2) GEN5i ships with keyboard layout in English, German, French, Chinese or Japanese. Specify on order.







Software Options, to be ordered separately <sup>(1)</sup>		
Article	Description	Order No.
CSI Interface	Allows the development of and running CSI programs.	1-PERC-OP-CSI-01-2
RPC/COM	Remote control of Perception, including basic hardware setup and control.	1-PERC-OP-IF-01-2
BE256/MP control	To control a single BE256 or a single MultiPro from Perception via IEEE488 interface.	1-PERC-OP-BE-01-2
SEQUENCE	To control BE3200 Test Sequencer from Perception via USB port. Requires Perception Standard or higher (1-PERC-ST-01-2).	1-PERC-OP-SEQ-01-2
STL Analysis	Special analysis routines according to the STL standard used in LV, MV and HV labs. Includes import of TGD data (Test Data Generator) for verification. Requires Analysis option (1-PERC-OP-AN-01-2).	1-PERC-OP-STL-01-2
HPHV-AA	HighPower/HighVoltage automated analysis. Evaluates data of NoLoad, ShortCircuit, Capacitive and Synthetic tests of HV/MV switchgear devices (requires signals from tripping coils and travel to be recorded). Requires STL Analysis option (1-PERC-OP-STL-01-2).	1-PERC-OP-HHP-01-2
HV-IA	High Voltage Impulse Analysis option; evaluates Lightning, Switching and Current impulses; designed according to IEC60060-1 and IEC61083-2 requirements. Allows evaluation with new k-factor method.	1-PERC-OP-HIA-01-2

(1) Software options are also sold in multiple licenses packages and multiple network license seats.

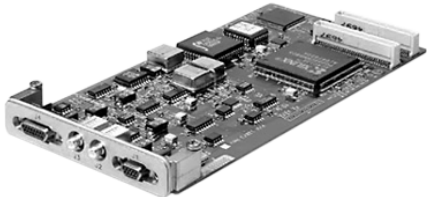



## Windows PC Storage options, to be ordered separately

Article		Description	Order No.
Internal system solid state disk		<p>Factory installed option.</p> <p>Windows® 7 64 Bit preinstalled internal system solid state disk. Replaces internal system hard disk with an internal 2.5" RAID 0 solid state disk. Unformatted capacity 600 GB. Continuous streaming rate 100 MB/s.<sup>(1)</sup></p> <p>Cannot be combined with options 1-G010-2 and 1-G016-2.</p>	1-G014-2
Removable system hard disk		<p>Factory installed option.</p> <p>Windows® 7 64 Bit preinstalled removable system hard disk. Replaces internal system hard disk with an 2.5" RAID 0 hard disk in the removable bay. Unformatted capacity 640 GB. Continuous streaming rate 40 MB/s.<sup>(1)</sup></p> <p>Cannot be combined with options 1-G014-2, 1-G016-2, 1-G035-2 and 1-G015-2.</p>	1-G010-2
Removable system solid state disk		<p>Factory installed option.</p> <p>Windows® 7 64 Bit preinstalled removable system solid state disk. Replaces internal system hard disk with a 2.5" RAID 0 solid state disk in the removable bay. Unformatted capacity 600 GB. Continuous streaming rate 100 MB/s.<sup>(1)</sup></p> <p>Cannot be combined with options 1-G010-2, 1-G014-2, 1-G035-2 and 1-G015-2.</p>	1-G016-2
Removable data hard disk		<p>Removable 2.5" data hard disk mounted in an additional carrier bay. One disk installed per bay. Bays can be exchanged when the disk is not used. Perception can use this disk as standard storage disk. Unformatted capacity 320 GB. Continuous streaming rate 25 MB/s.<sup>(1)</sup></p> <p>Cannot be combined with options 1-G010-2 and G016-2.</p>	1-G035-2
Removable solid state disk		<p>Removable 2.5" data solid state disk mounted in an additional carrier bay. One disk installed per bay. Bays can be exchanged when the disk is not used. Perception can use this disk as standard storage disk. Unformatted capacity 300 GB. Continuous streaming rate 100 MB/s.<sup>(1)</sup></p> <p>Cannot be combined with options 1-G010-2 and G016-2.</p>	1-G015-2
PC USB carrier - US		<p>External USB-based carrier; connects removable data drive bay (1-G035-2 or 1-G015-2) to a USB port of a windows PC. Perception software can directly read the stored PNRF files. Comes with US power supply.</p>	1-G504-2
PC USB carrier - UK		<p>External USB-based carrier; connects removable data drive bay (1-G035-2 or 1-G015-2) to a USB port of a windows PC. Perception software can directly read the stored PNRF files. Comes with UK power supply.</p>	1-G505-2
PC USB carrier - EU		<p>External USB-based carrier; connects removable data drive bay (1-G035-2 or 1-G015-2) to a USB port of a windows PC. Perception software can directly read the stored PNRF files. Comes with EU power supply.</p>	1-G506-2

(1) Systems shipped before January 2013 use smaller disk size and lower continuous streaming rates.

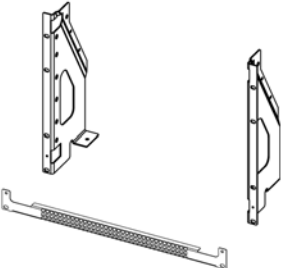
Options, to be ordered separately			
Article		Description	Order No.
IRIG PMC card		Factory installed option. GEN DAQ IRIG interface fits into open XMC/PMC slot of GEN DAQ Interface/Controller module. Cannot be used in combination with 10 Gbit Ethernet XMC card.	1-G001-1
IRIG/GPS PMC card		Factory installed option. GEN DAQ IRIG/GPS interface fits into open XMC/PMC slot of GEN DAQ Interface/Controller module, comes with antenna and 15 m cable. Cannot be used in combination with 10 Gbit Ethernet XMC card.	1-G002-2
Solid State Disk		Factory installed option. GEN DAQ Internal SSD drive in GEN DAQ mainframe, 300 GB capacity, 50 MB/s continuous streaming rate. Sweep storage rate depending on sweep length and number of channels. Short sweeps are stored slower due to administration overhead.	1-G061-2
1 Gbit Optical Network SFP module 850 nm		GEN DAQ 1Gbit Ethernet SFP, 850 nm Multi Mode, up to 500 m optical cable length supported, LC connector support. 1 Gbit SFP modules are not compatible with the 10 Gbit SFP+ modules.	1-G062-2
1 Gbit Optical Network SFP module 1310 nm		GEN DAQ 1Gbit Ethernet SFP, 1310 nm Single Mode, up to 10 km optical cable length supported, LC connector support. 1 Gbit SFP modules are not compatible with the 10 Gbit SFP+ modules.	1-G063-2
10 Gbit Ethernet XMC card		Factory installed option. GEN DAQ 10 Gbit Ethernet XMC card adds up to 2 extra 10 Gbit Ethernet network connections to a GEN DAQ series mainframe. Supports up to 200 MB/s continuous data transfer from the GEN DAQ mainframe to an appropriate PC. Requires a 10 Gbit optical network SFP+ module. Cannot be used in combination with IRIG or IRIG/GPS PMC card.	1-G064-2
10 Gbit Optical Network SFP+ module 850 nm		GEN DAQ 10Gbit Ethernet SFP+, 850 nm Multi Mode, up to 66 m optical cable length supported, LC connector support. 10 Gbit SFP+ modules are not compatible with the 1 Gbit SFP modules.	1-G065-2
10 Gbit Optical Network SFP+ module 1310 nm		GEN DAQ 10Gbit Ethernet SFP+, 1310 nm Single Mode, up to 10 km optical cable length supported, LC connector support. 10 Gbit SFP+ modules are not compatible with the 1 Gbit SFP modules.	1-G066-2
Master/Slave card		GEN DAQ Master/Slave option. Uses first slot in GEN16t rack, GEN2i and GEN5i integrated mainframes and the Master/Slave slot in GEN7t tower mainframe. The Master/Slave card is needed in master and any slave mainframe. Supports up to eight slaves using optical connections. Single 3 m (10 feet) optical cable included.	1-G040-2

## Accessories, to be ordered separately

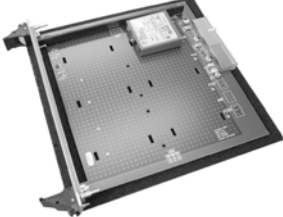
Article		Description	Order No.
GEN5i Carrying Bag		GEN5i Soft-Sided Carrying Case. Protects the GEN5i from scratches while carrying it around. Slides around the GEN5i with access to the standard carrying handle.	1-G036-2
GEN5i 19 inch rack mount kit		GEN5i rack mount kit (does not include mouse and keyboard mountings). User installed option.	1-G038-2
GEN5i shipping case		GEN5i shipping case, with wheels and handle Tested according to ASTM D4169-04 Level I (drop), and ASTM D4728 E (vibration & shock) Gross weight (empty) 20.3 kg (44.75 lbs).	1-G037-2
Fiber optic Multi Mode standard cable		GEN DAQ standard zipcord fiber optic Multi Mode cable, 3.0 dB/km loss, LC-LC connectors, orange. Used with 850 nm optical 1 Gbit or 10 Gbit Ethernet. (1-G062-2 and 1-G065-2) and Master/Slave synchronizations. Lengths 3, 10, 20 and 50 meter (10, 33, 66 and 164 feet)	1-KAB280-3 1-KAB280-10 1-KAB280-20 1-KAB280-50
Fiber optic Single Mode standard cable		GEN DAQ standard zipcord fiber optic Single Mode cable, 0.5 dB/km loss, LC-LC connectors, yellow. Used with 1310 nm optical 1 Gbit or 10 Gbit Ethernet. (1-G063-2 and 1-G066-2). Lengths 2, 10, 20, 50 and 100 meter (6.5, 33, 66, 164 and 328 feet)	1-KAB288-2 1-KAB288-10 1-KAB288-20 1-KAB288-50 1-KAB288-100
Fiber optic Single Mode heavy duty cable		GEN DAQ heavy duty indoor/outdoor fiber optic Single Mode cable, 0.5 dB/km loss, LC-LC connectors, black. Used with 1310 nm optical 1 Gbit or 10 Gbit Ethernet. (1-G063-2 and 1-G066-2). Lengths 10, 20, 50, 100, 150 and 300 meter (33, 66, 164, 328, 492 and 984 feet)	1-KAB289-10 1-KAB289-20 1-KAB289-50 1-KAB289-100 1-KAB289-150 1-KAB289-300
5B carrier card		GEN DAQ 5B Carrier. Uses one GEN DAQ slot, holds up to six 5B modules. 5B modules, I/O connectors and cabling not included. Basic card required for acquisition.	1-G028-2

©Hottinger Baldwin Messtechnik GmbH. All rights reserved.  
All details describe our products in general form only.  
They are not to be understood as express warranty and do  
not constitute any liability whatsoever.

**Hottinger Baldwin Messtechnik GmbH**

Im Tiefen See 45 · 64293 Darmstadt · Germany  
Tel. +49 6151 803-0 · Fax: +49 6151 803-9100  
E-mail: [info@hbm.com](mailto:info@hbm.com) · [www.hbm.com](http://www.hbm.com)

**measure and predict with confidence**

