

PME industrial  
measurement  
electronics linked  
to a field bus

## MP55 module





<b>Contents</b>	<b>Page</b>
<b>Safety instructions</b> .....	<b>4</b>
<b>1 Introduction</b> .....	<b>9</b>
1.1 Scope of supply and accessories .....	9
1.2 General .....	9
<b>2 Selecting amplifier settings with DIP switches</b> .....	<b>10</b>
<b>3 Mounting/dismounting MP55</b> .....	<b>14</b>
3.1 Connecting several modules .....	15
<b>4 Connection</b> .....	<b>16</b>
4.1 Overview of MP55 functions .....	16
4.2 Supply voltage and control inputs/outputs .....	17
4.2.1 External supply voltage for control outputs .....	18
4.3 Transducers .....	19
4.3.1 Connecting transducers in a four-wire configuration .....	19
4.3.2 Connecting transducers when cables are more than 50 m long .....	20
4.4 CAN interface .....	21
4.5 Synchronization .....	22
<b>5 Setting and operating (MP55)</b> .....	<b>24</b>
5.1 Operating philosophy .....	24
5.2 Starting up .....	27
5.3 Overview of all groups and parameters .....	28
5.3.1 Setting all parameters .....	29
<b>6 Clarification of important parameters</b> .....	<b>33</b>
<b>7 CAN interface description</b> .....	<b>41</b>
7.1 General .....	41
7.2 Cyclic transmission of measured values .....	41
7.3 Parameterization .....	42
7.4 Object dictionary: Communication profile range in accordance with CANopen (CiA-DS301) .....	44
7.5 Object dictionary: manufacturer-specific objects .....	47
7.6 Manufacturer-specific objects in FLOAT data format .....	56
7.7 Examples .....	58
<b>8 Error messages/operating state (LED)</b> .....	<b>60</b>
<b>9 Index</b> .....	<b>63</b>

## Safety instructions

Before commissioning, make sure that the mains voltage and type of current stated on the identification plate match the mains voltage and type of current at the place of operation and that the circuit used is efficiently protected.

**As the device does not have its own power switch, the supply cable connected to it must not be directly applied to the mains supply. The supply voltage must be 18 to 30 V. According to the VDE directive, there must be a switching device present (such as a power switch) to disconnect these devices from the mains. It is essential to ensure that the device can be quickly disconnected from the mains supply at any time.**

The supply connection, as well as the signal and sense leads, must be installed in such a way that electromagnetic interference does not adversely affect device functionality (HBM recommendation: “Greenline shielding design”, downloadable from the Internet at <http://www.hbm.com/Greenline>).

Automation equipment and devices must be installed in such a way that adequate protection or locking against unintentional actuation is provided (e.g. access checks, password protection, etc.).

When devices are working in a network, these networks must be designed in such a way that malfunctions in individual nodes can be detected and shut down.

Safety precautions must be taken both in terms of hardware and software, so that a line break or other interruption to signal transmission, such as via the bus interfaces, do not cause undefined states or loss of data in the automation device.

### Intended use

The MP55 module with connected transducers is to be used exclusively for measurement tasks and directly related control tasks. Use for any purpose other than the above is deemed to be non-designated use.

In the interests of safety, the device should only be operated as described in the Operating Manual. It is also essential to comply with the legal and safety requirements for the application concerned during use. The same applies to the use of accessories.

Each time, before starting up the equipment, you must first run a project planning and risk analysis that takes into account all the safety aspects of

automation technology. This particularly concerns personal and machine protection.

Additional safety precautions to establish safe operating conditions in the event of a fault, must be taken in plants where malfunctions could cause major damage, loss of data or even personal injury.

This can be done, for example, by error signaling, limit value switches, mechanical interlocking, etc.

### **General dangers of failing to follow the safety instructions**

The MP55 module is a state of the art unit and as such is failsafe. The device may give rise to residual dangers if it is inappropriately installed and operated by untrained personnel.

Any person instructed to carry out installation, commissioning, maintenance or repair of the device must have read and understood the Operating Manual and in particular the technical safety instructions.

### **Conditions at the place of installation**

Protect the devices from moisture and dampness or weather such as rain, snow, etc.

Do not expose the device to direct sunlight. Ensure that there is adequate ventilation.

### **Maintenance and cleaning**

The MP55 module is maintenance free. Please note the following points when cleaning the housing:

- Before cleaning, disconnect the device from the power supply.
- Clean the housing with a soft, slightly damp (not wet!) cloth. You should **never** use solvent, since this could damage the labeling on the front panel and the display.
- When cleaning, ensure that no liquid gets into the device or connections.

## Residual dangers

The scope of supply and performance of the MP55 covers only a small area of measurement technology. In addition, equipment planners, installers and operators should plan, implement and respond to the safety engineering considerations of measurement technology in such a way as to minimize residual dangers. On-site regulations must be complied with at all times. There must be reference to the residual dangers connected with measurement technology.

Any risk of residual dangers when working with the MP55 is pointed out in these instructions by means of the following symbols:

Symbol:  **WARNING**

*Meaning:* **Dangerous situation**

Warns of a **potentially** dangerous situation in which failure to comply with safety requirements **can** lead to death or serious physical injury.

Symbol:  **CAUTION**

*Meaning:* **Possibly dangerous situation**

Warns of a **potentially** dangerous situation in which failure to comply with safety requirements **could** lead to damage to property and slight or moderate physical injury.

Symbol:  **NOTE**

Means that important information about the product or its handling is being provided.

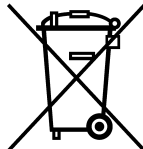
Symbol: 

*Meaning:* **Statutory waste disposal mark**

In accordance with national and local environmental protection and material recovery and recycling regulations, old devices that can no longer be used must be disposed of separately and not with normal household garbage. If you need more information about waste disposal, please contact your local authorities or the dealer from whom you purchased the product.

Symbol: 

Meaning: **CE mark**

The CE mark enables the manufacturer to guarantee that the product complies with the requirements of the relevant EC directives (the Declaration of Conformity can be found at <http://www.hbm.com/HBMdoc>).

### **Working safely**

Error messages should only be acknowledged once the cause of the error is removed and no further danger exists..

The device complies with the safety requirements of DIN EN 61010 Part 1 (VDE 0411 Part 1).

The device must be mounted on a support rail connected to grounded conductor potential. Both the support rail and the MP55/MP55DP module must be free of paint, varnish and dirt at the point of installation.

To ensure adequate immunity from interference, the bus cables (CAN and for MP55DP, Profibus DP) must be shielded, twisted-pair lines. The transducer cables must also be shielded. To ensure adequate immunity from interference, use only the Greenline shielding concept (place the shield of the transducer cable onto the connector housing).

The cables of the MP55/MP55DP digital inputs and outputs that are used should not be longer than 30 meters and should not exit the building in which the system is located. Otherwise it will not be possible to ensure that the device works perfectly. Strong magnetic fields or lightning strikes may have a destructive effect.

When connecting cables (fitting and extracting terminals), measures must be taken to prevent electrostatic discharge which could damage the electronics.

The MP55/MP55DP module must be operated with a separated extra-low voltage (18 to 30 V DC supply voltage), which usually supplies one or more consumers within a control cabinet.

Should the device be operated on a DC voltage network<sup>1)</sup>, additional precautions must be taken to discharge excess voltages.

<sup>1)</sup> Distribution system for electrical energy with greater physical expansion (over several control cabinets, for example) that may also supply consumers with high nominal (rated) currents.

## Conversions and modifications

The MP55 module must not be modified from the design or safety engineering point of view except with our express agreement. Any modification shall exclude all liability on our part for any damage resulting therefrom.

In particular, any repair or soldering work on motherboards is prohibited. When exchanging complete modules, use only original parts from HBM.

The device is delivered from the factory with a fixed hardware and software configuration. Changes can only be made within the possibilities documented in the manuals.

## Qualified personnel

This device is only to be installed and used by qualified personnel strictly in accordance with the specifications and with the safety rules and regulations which follow.

This includes people who meet at least one of the three following requirements:

- Knowledge of the safety concepts of automation technology is a requirement and as project personnel, you must be familiar with these concepts.
- As automation plant operating personnel, you have been instructed how to handle the machinery. You are familiar with the operation of the equipment and technologies described in this documentation.
- As commissioning engineers or service engineers, you have successfully completed the training to qualify you to repair the automation systems. You are also authorized to activate, ground and label circuits and equipment in accordance with safety engineering standards.

It is also essential to comply with the legal and safety requirements for the application concerned during use. The same applies to the use of accessories.

Qualified personnel means persons entrusted with siting, mounting, starting up and operating the product, who possess the appropriate qualifications for their function.



## 1 Introduction

### 1.1 Scope of supply and accessories

#### Scope of supply:

- 1 MP55 module
- 3 6-pin plug terminals, coded  
Order-no.: 3.3312-0427 (plug terminal 3);  
3.3312-0428 (plug terminal 4); 3.3312-0426 (plug terminal 1)
- Flat ribbon cable female connector, 10-pin
- Extra spring for enclosure assembly (included in the pack)
- 1 MP55 module Operating Manual

#### Accessories:

- 15-pin Sub-D plug for transducers, Order no.: 3.3312-0182
- Standard flat ribbon cable, 10 pin, 1.27 mm pitch

### 1.2 General

The MP55 module from the PME product line is a carrier-frequency amplifier suitable for connecting force transducers, pressure transducers, torque transducers, displacement transducers and load cells for a wide variety of technologies. The MP55 module is set up and parameterized via a keyboard and display, or by using the PME Assistant. The PME Assistant provides a simple user interface under MS-Windows for parameterizing the modules (in the “PME Assistant” Online Help).

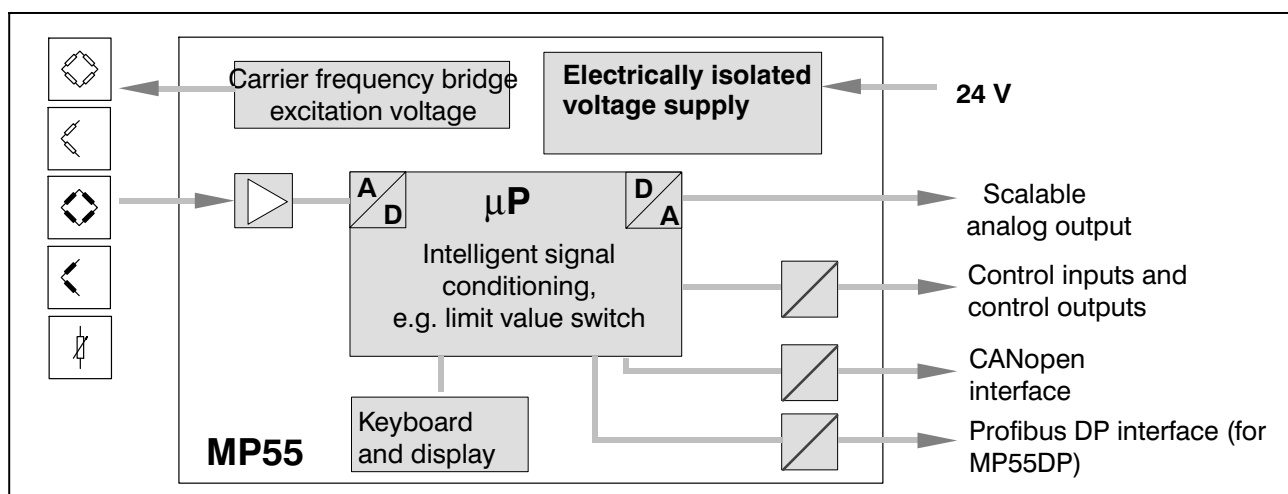

**Fig. 1.1:** Block diagram of the MP55 module

## 2 Selecting amplifier settings with DIP switches



### NOTE

The DIP switches must be set or changed before mounting the PME.

The different settings are defined with the DIP switches and can be read out over the display (see chapter 5.3). These are the settings for

bridge excitation voltage, measuring range, bridge type, analog output, synchronization, bus termination resistor, edge steepness

To set the DIP switches, proceed as shown in Fig. 2.1.

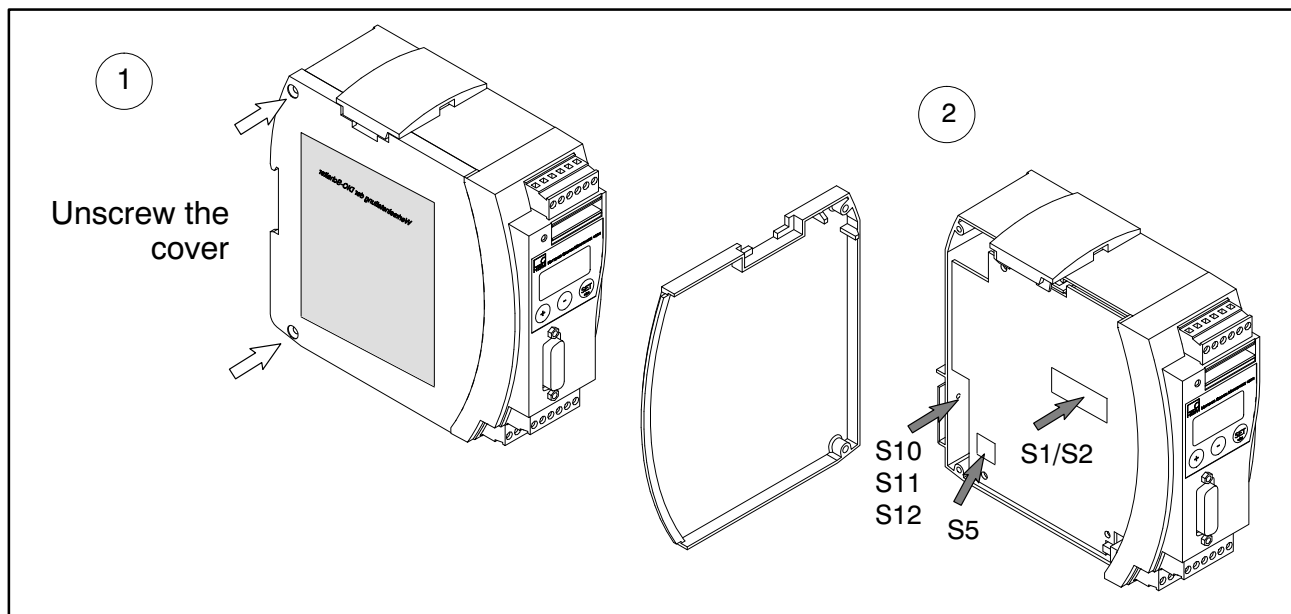

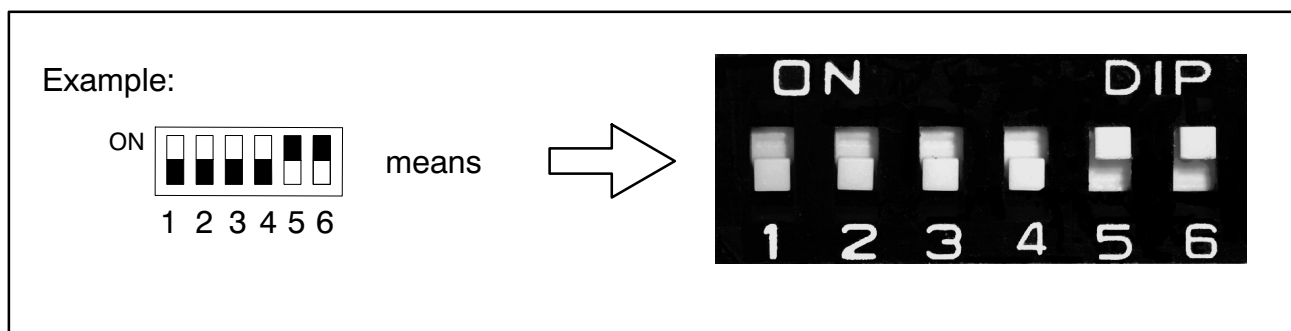

**Fig. 2.1:** Open the housing, DIP switch positions



**Fig. 2.2:** Switch convention

**Factory settings:**

-  **Lower board:** S10, S11 and S12 and S5
-  **Upper board:** S1 and S2

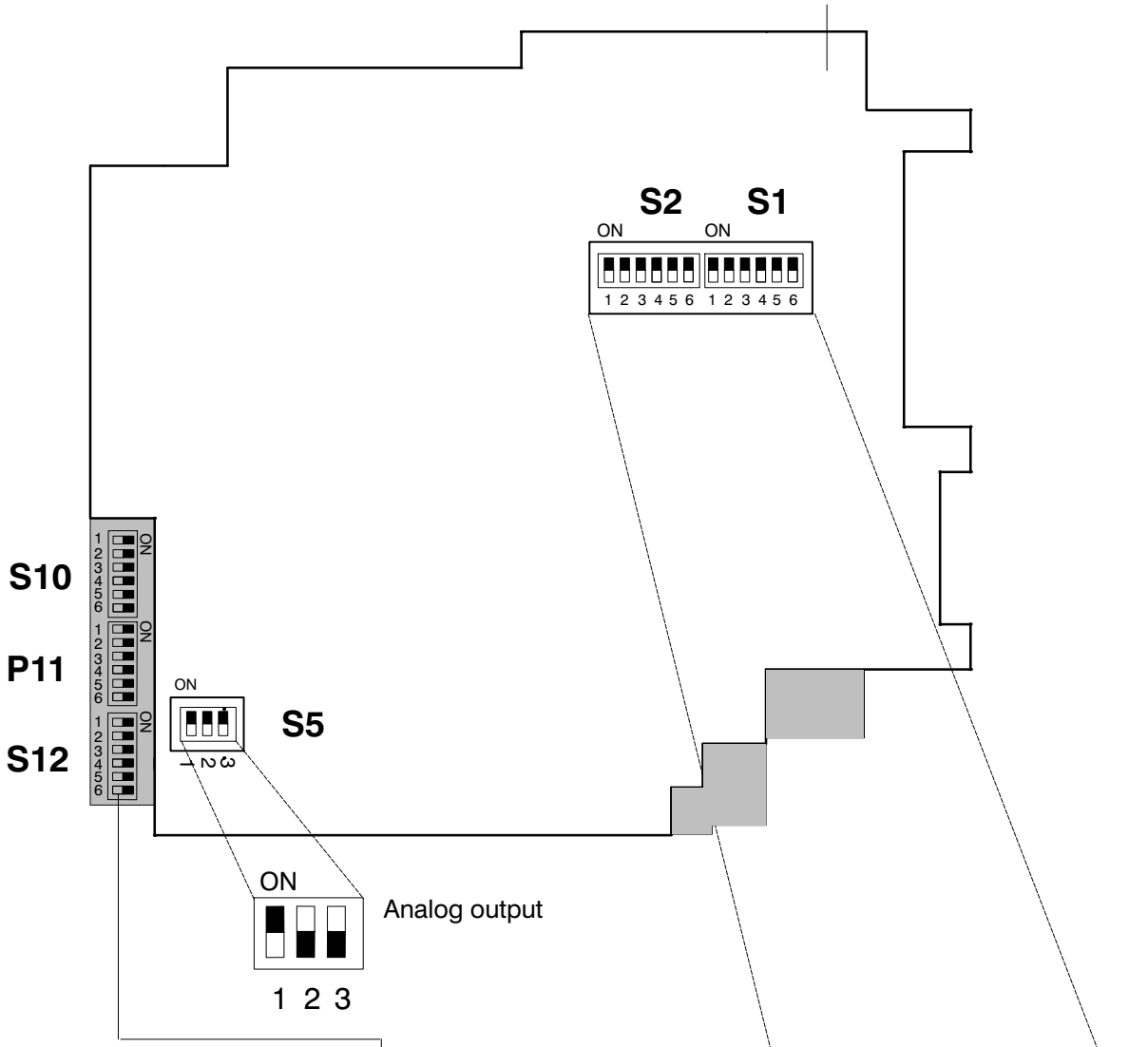

**S10** ON

1	2	3	4	5	6
---	---	---	---	---	---

Synchronization

**S11** ON

1	2	3	4	5	6
---	---	---	---	---	---

Analog output

Input range

**S12** ON

1	2	3	4	5	6
---	---	---	---	---	---

Bridge excitation voltage

Bridge type

**S2** ON

1	2	3	4	5	6
---	---	---	---	---	---

Bridge excitation voltage

**S1** ON

1	2	3	4	5	6
---	---	---	---	---	---

Bridge type

Input range

**WARNING**

 The switch positions must not be changed!

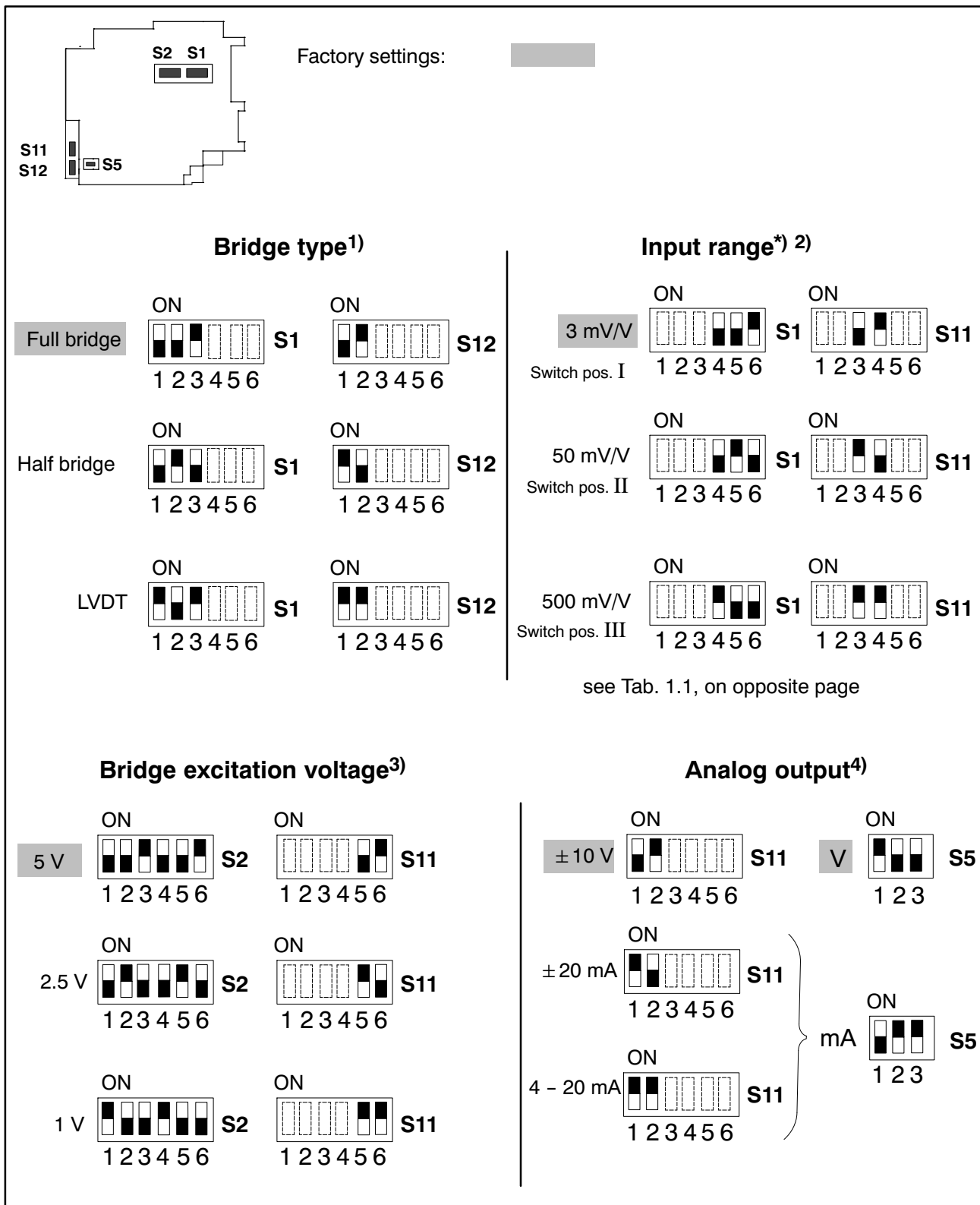

**Fig. 2.3:** Setting the amplifier

- 1) Look/check in display under TRANSDUCER group, "Transd.typ" parameter; see page 25
  - 2) Look/check in display under TRANSDUCER group, "Input" parameter; see page 25
  - 3) Look/check in display under TRANSDUCER group, "Excitation" parameter; see page 25
  - 4) Look/check in display under ANALOG OUTPUT group, "UaMode" parameter; see page 25
- \* **mV/V values relate to 5 VU<sub>B</sub>** (see table Tab. 1.1 on next page)

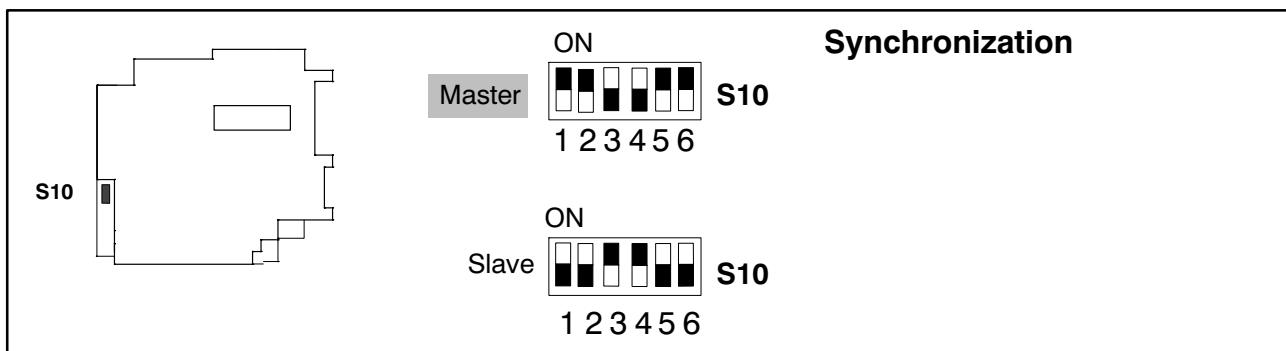

Fig. 2.4: Setting the amplifier (contd.)

**Bus termination resistor**

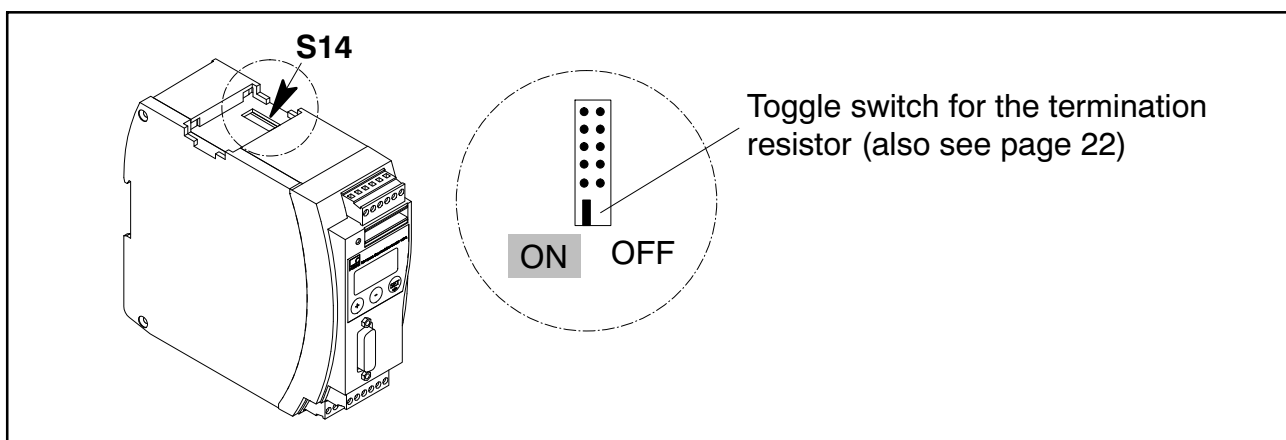

Fig. 2.5: Switch for the CAN Bus termination resistor (basic diagram)

Bridge excitation voltage (V)	Input range (mV/V)		
	Switch position I	Switch position II	Switch position III
5	3	50	500
2.5	6	100	1000
1	15	250	2500

Tab. 1.1: Input ranges for different bridge excitation voltages

Transducer type and nominal (rated) data	Bridge type	Bridge excitation voltage	Input range
SG transducer 2 mV/V=20 kN	Full bridge	5 V	3 mV/V
Inductive displ. transducer 80 mV/V	Half bridge	2.5 V	100 mV/V
Inductive displ. transducer 10 mV/V	Half bridge	1 V	15 mV/V
Piezoresistive transducer 400 mV/V	Half bridge	1 V	250 mV/V
Potentiometric transducer 1000 mV/V	Half bridge	2.5 V	1000 mV/V

Tab. 1.2: Useful combinations

### 3 Mounting/dismounting MP55

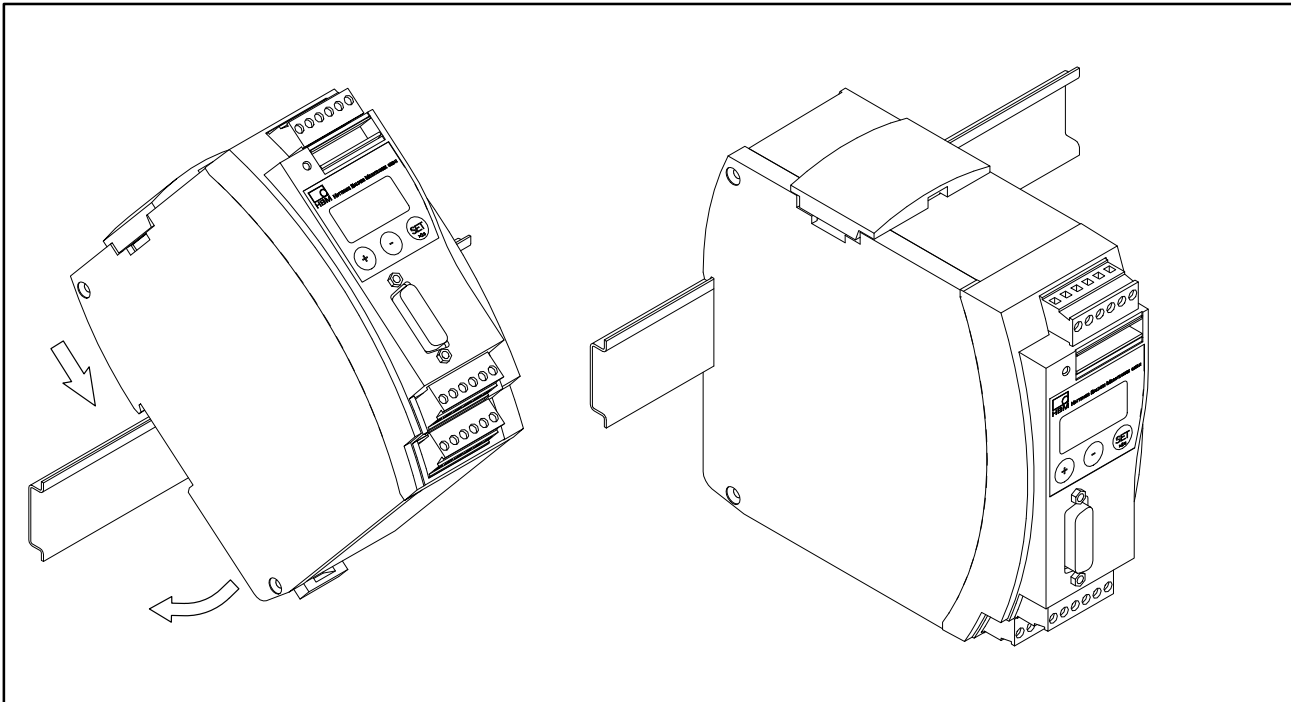

**Fig. 3.1:** Mounting on a support rail

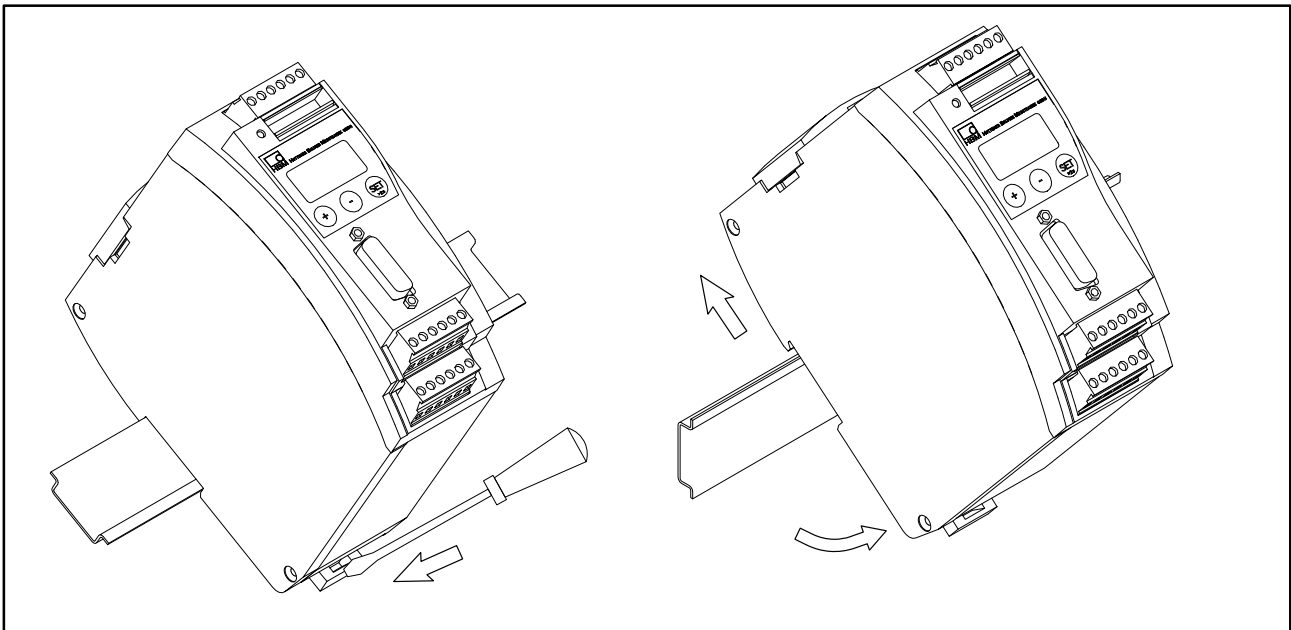
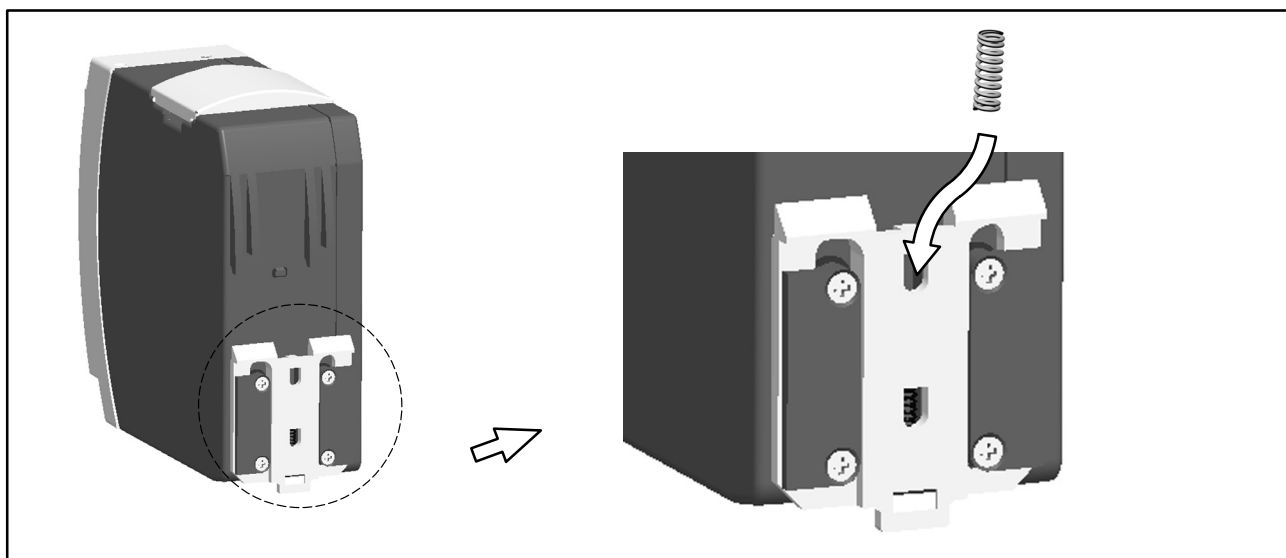

**Fig. 3.2:** Dismounting



**CAUTION**

The support rail must be connected to grounded conductor potential .



**Fig. 3.3:** Fitting a second spring for a more stable module mounting on the DIN rail

### 3.1 Connecting several modules

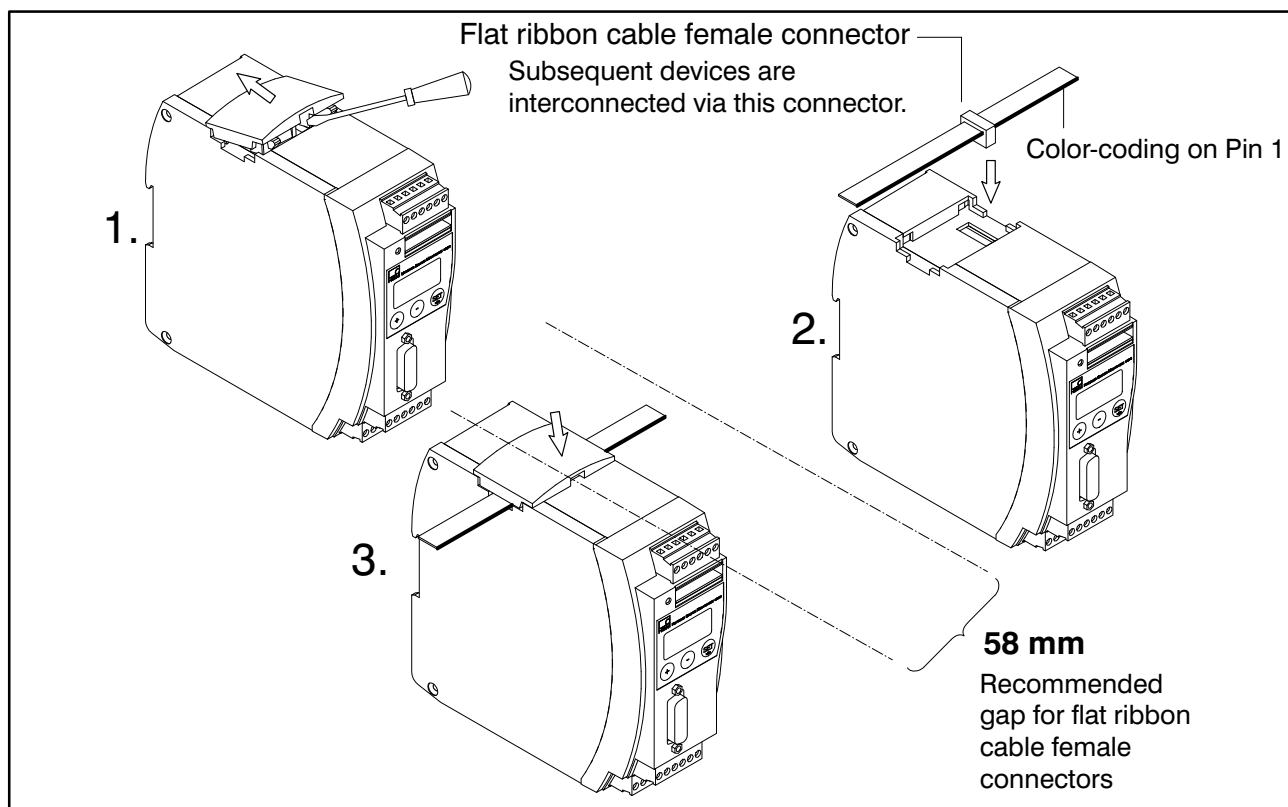

**Fig. 3.4:** Connecting a flat ribbon cable

Several MP55 modules can be connected via a flat ribbon cable. This cable provides the local supply voltage connection and synchronization between the modules. No more than eight modules should be interconnected via a flat ribbon cable.

## 4 Connection



### WARNING

Comply with the safety instructions before starting up the device.

### 4.1 Overview of MP55 functions

Local connection of CAN Bus and supply voltage and synchronization between modules, bus termination resistor

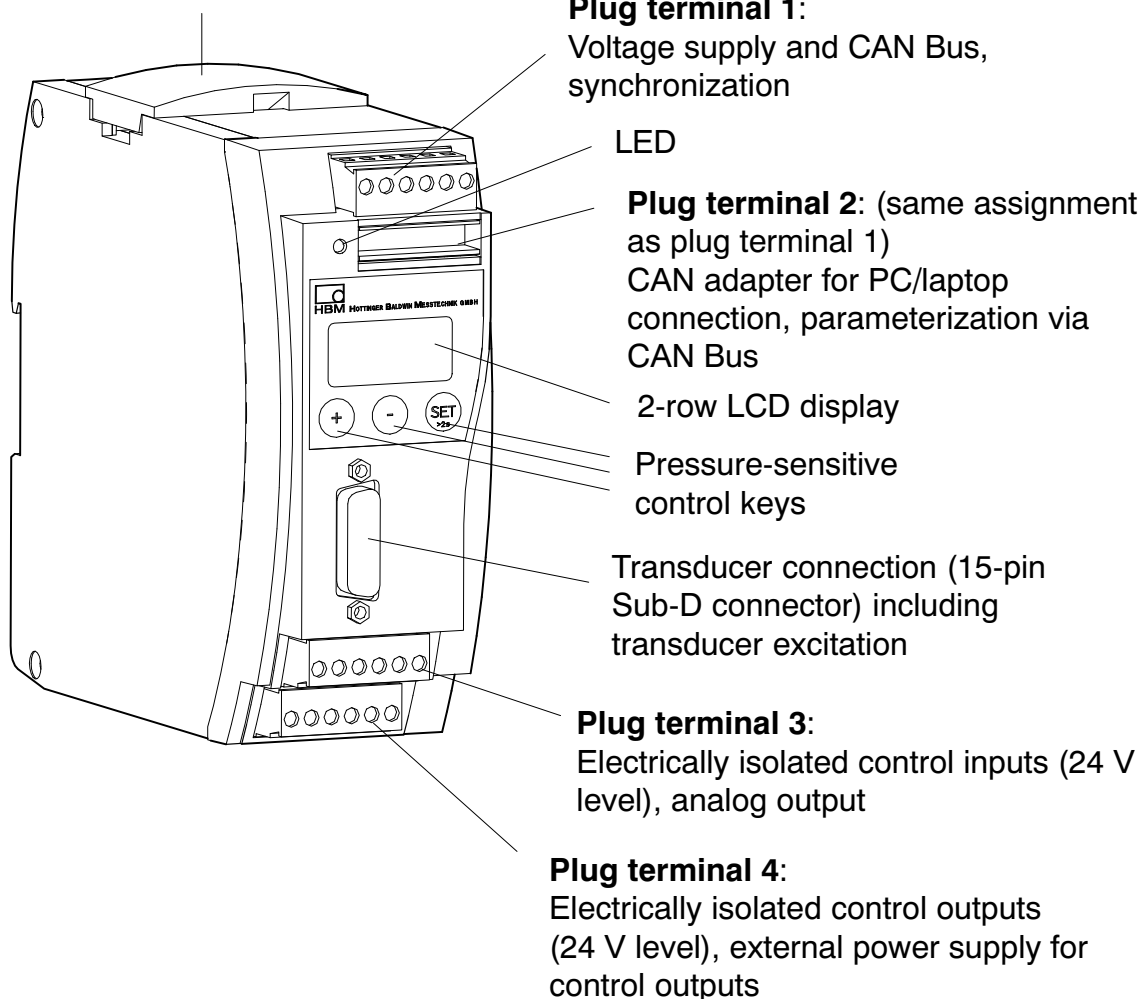



## 4.2 Supply voltage and control inputs/outputs

There are four removable plug terminals available for connection.

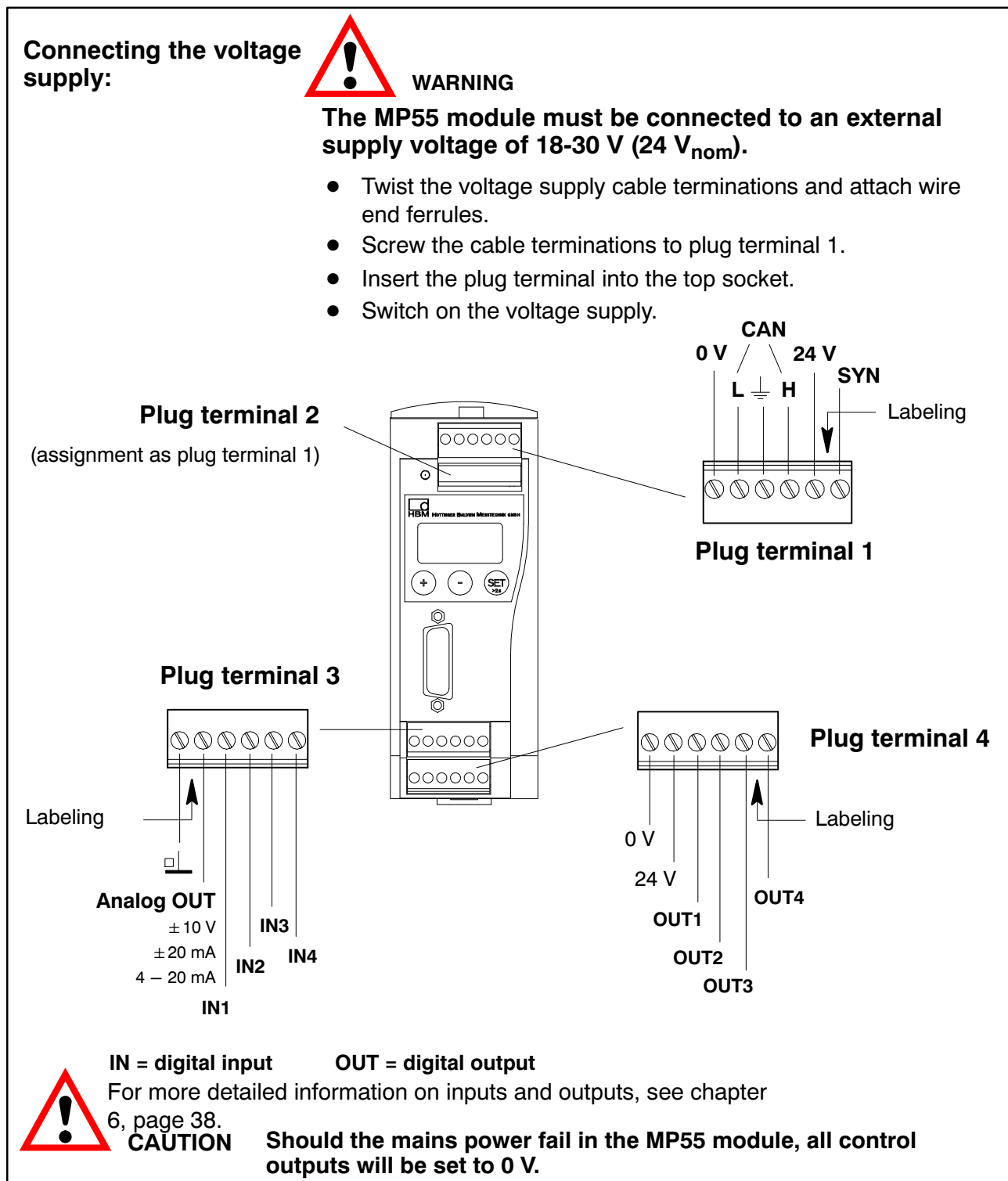
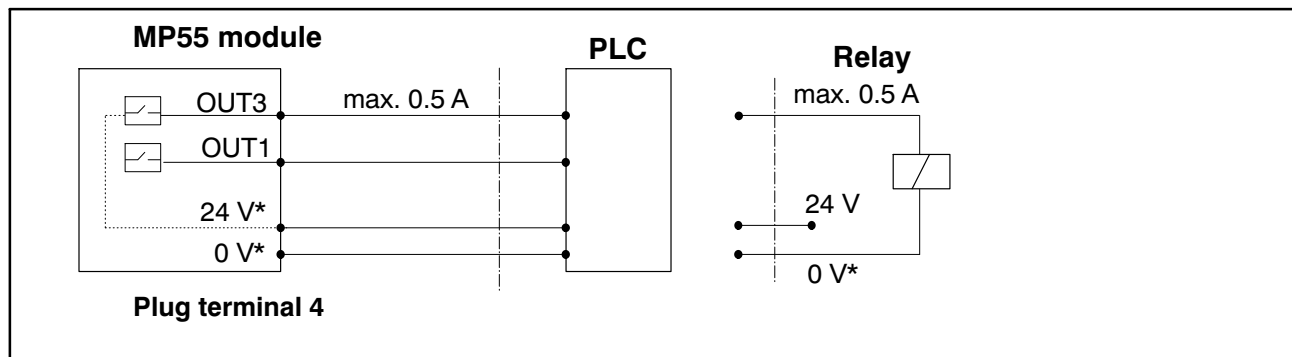

**Fig. 4.1:** Plug terminal assignment

The 4 plug terminals are coded, to prevent confusion when plugging them into the 4 sockets. The sockets are fitted with coding tabs, the plug terminals with coding pins.

### 4.2.1 External supply voltage for control outputs

Example: PLC connection



**Fig. 4.2:** Connection to a PLC

The control **inputs** are available at plug terminal 3, the control **outputs** at plug terminal 4, and are electrically isolated from the internal supply voltage (also see chapter 6, “Clarification of important parameters”, on page 33).

\*) The control outputs must be supplied with an external voltage (ground **and** 24 V).

### 4.3 Transducers

The following transducer types can be connected to the MP55 module:

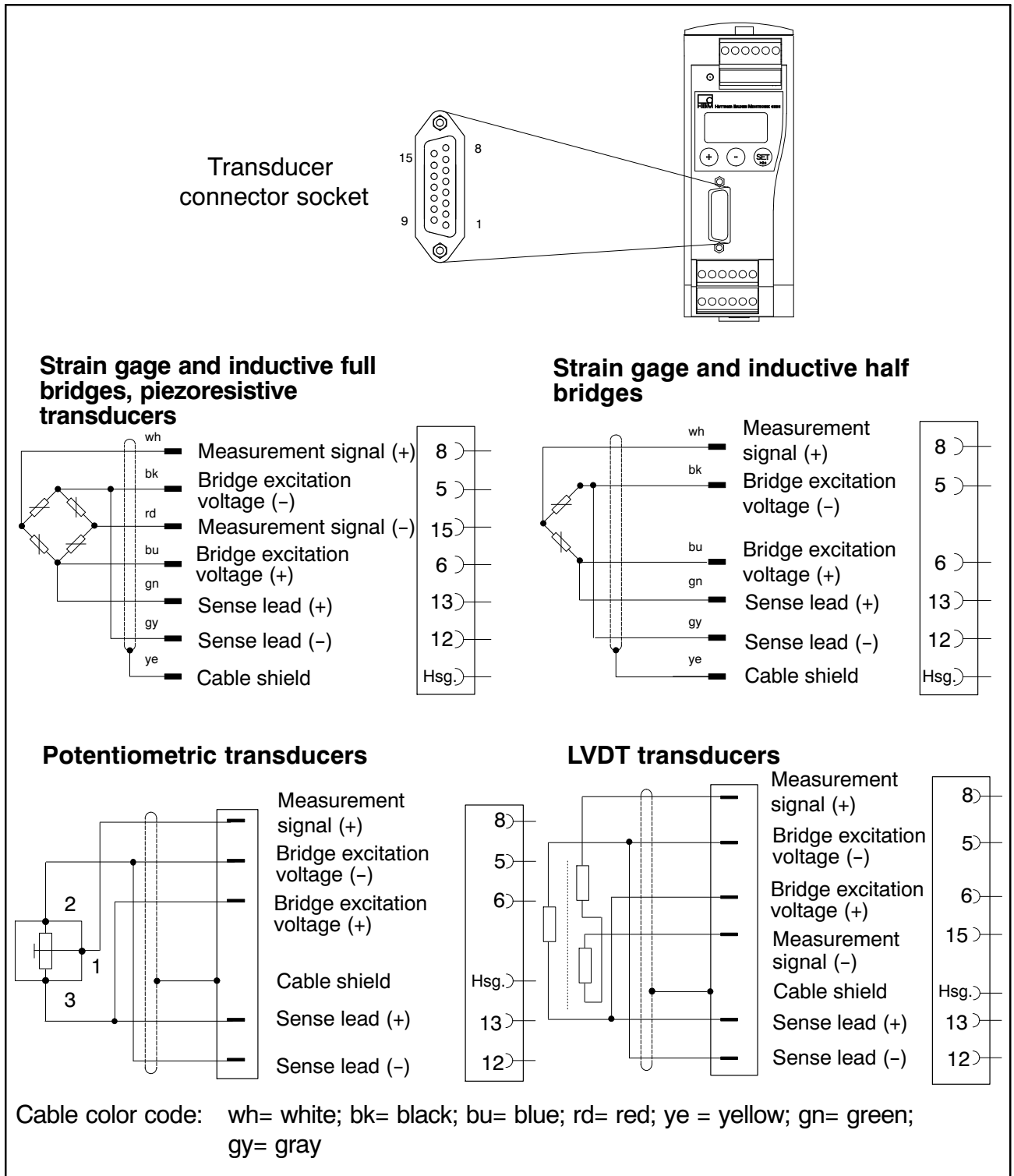

**Fig. 4.3:** Connecting different transducers

#### 4.3.1 Connecting transducers in a four-wire configuration

When connecting a transducer in a four-wire configuration with cables less than 50 m long, the sense leads must be connected to the relevant bridge excitation circuit (Pin 5 to Pin 12 and Pin 6 to Pin 13).

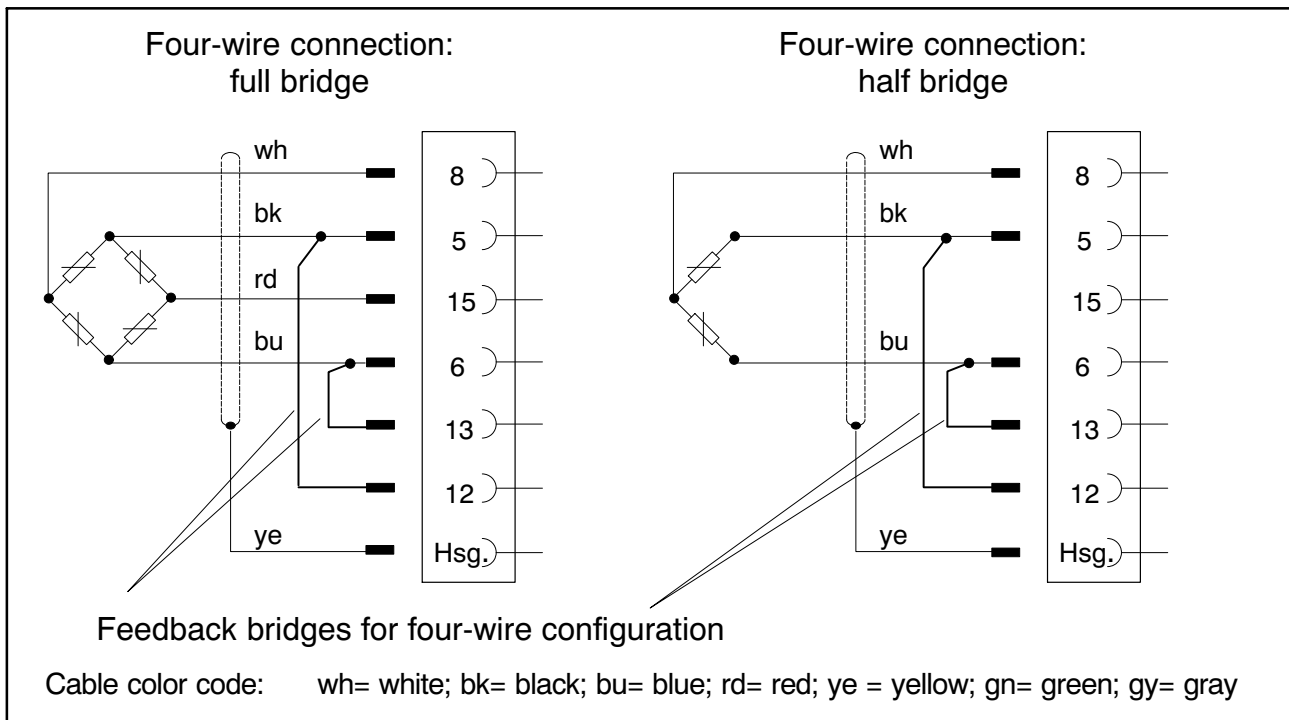

**Fig. 4.4:** Transducer connection in a four-wire-configuration



## NOTE

For extension cables, use only a six-wire configuration and use shielded, low-capacitance measurement cables that are twisted in pairs, such as those from HBM. Attach the shield of the transducer cable to the connector housing in accordance with the HBM Greenline concept, to ensure EMC protection (see HBM Greenline Information, document i1577).

### 4.3.2 Connecting transducers when cables are more than 50 m long

For cables more than >50 m long, a resistor of half the value of the bridge resistance ( $R_B/2$ ) must be activated at the transducer in each of the sense leads (Fig. 4.5). If the transducers are calibrated in a four-wire circuit, the resistors are used instead of feedback bridges (Fig. 4.6). The extension cable itself must always be implemented in a six-wire configuration.

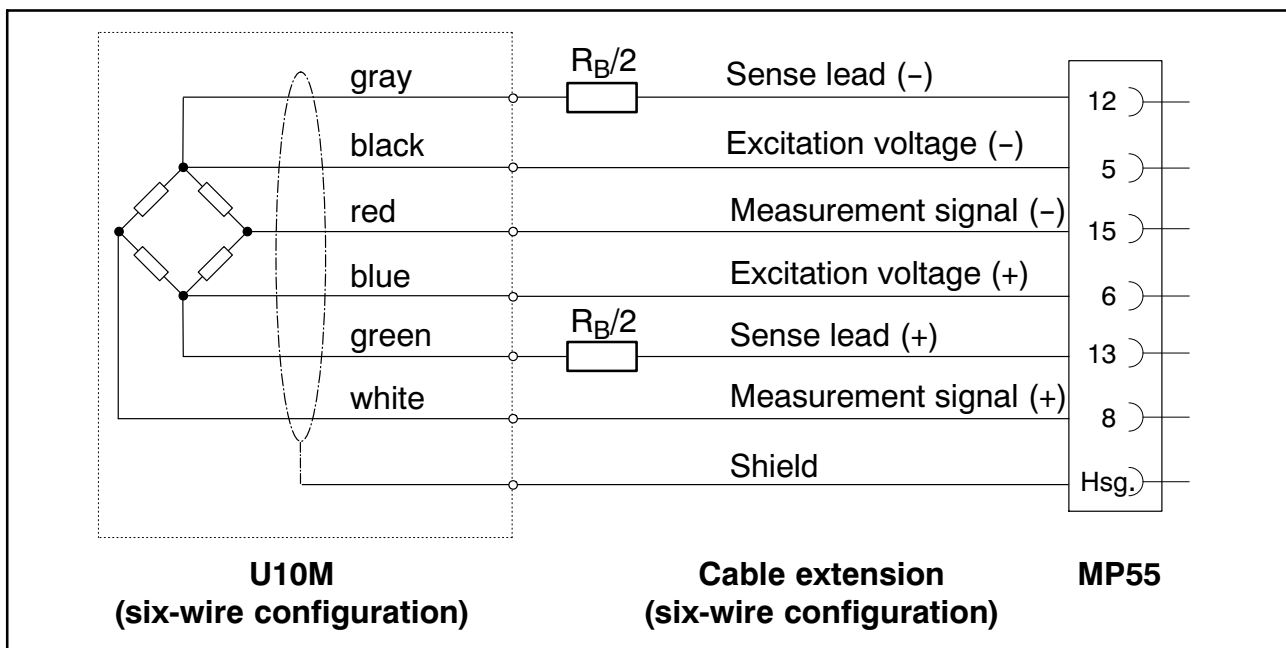

**Fig. 4.5:** Transducer connection for cables more than 50 m long; example with U10M force transducer (transducer in a six-wire circuit)

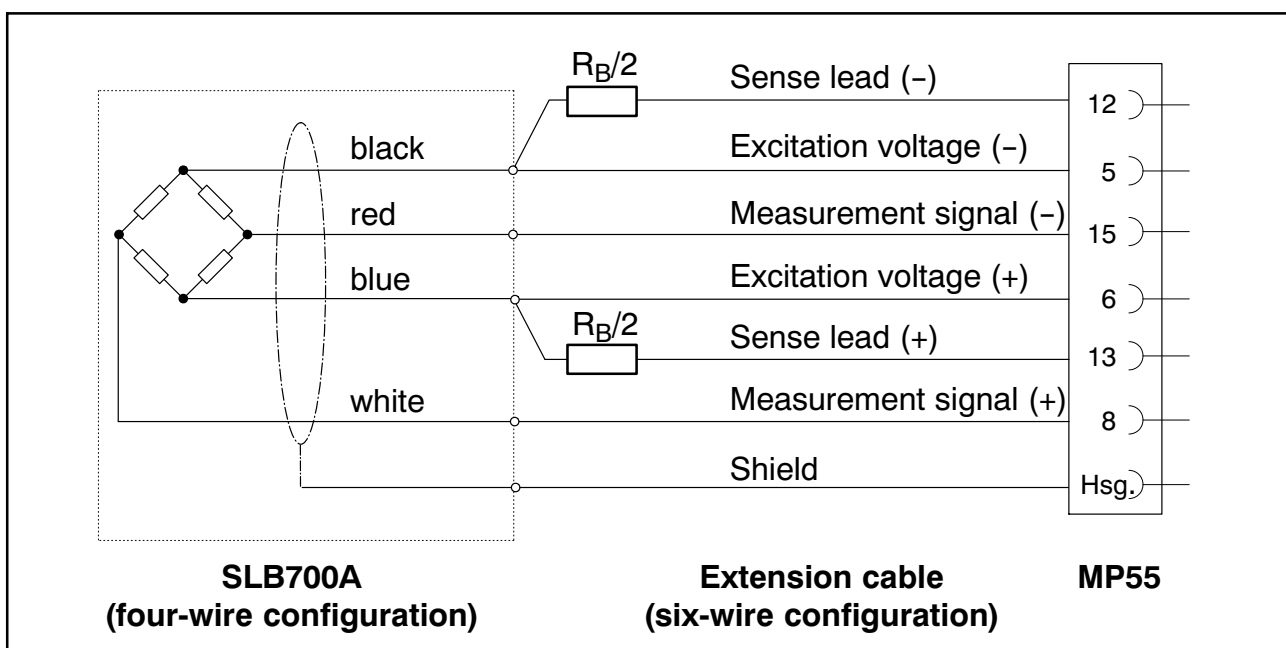

**Fig. 4.6:** Transducer connection for cables more than 50 m long; example with SLB700A strain transducer (transducer in a four-wire circuit)

### 4.4 CAN interface

The CAN Bus is connected via plug terminal 1. A maximum of 32 CAN nodes can be connected in one bus segment (in accordance with the CANopen specification).

The CAN Bus needs a termination resistor of 120  $\omega$  in the first and last bus nodes. The maximum number of termination resistors the bus cable can have

is two. A termination resistor is integrated into the MP55 module, and is activated by toggle-switch S14 (see page 13).

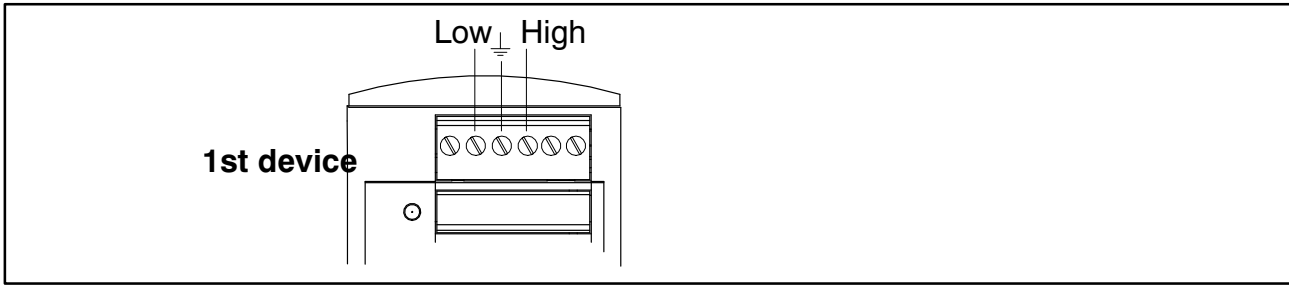

**Fig. 4.7:** CAN interface connection

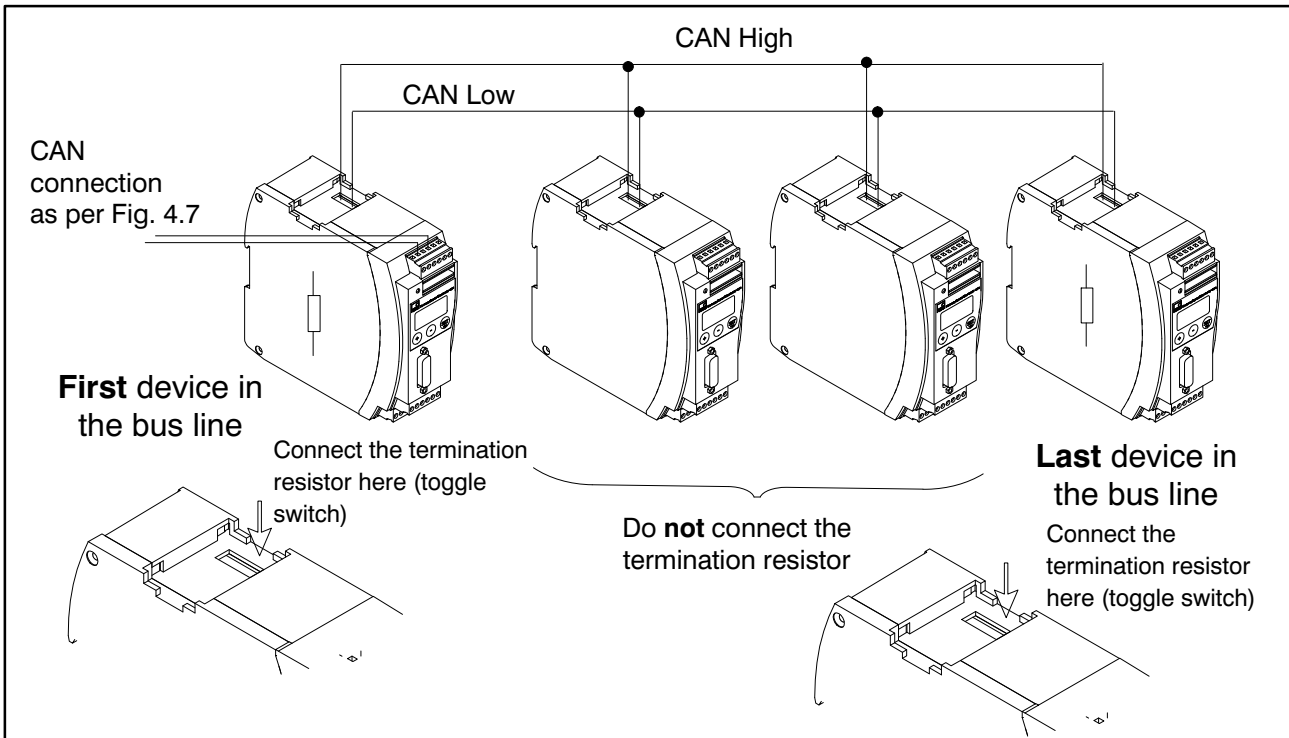

**Fig. 4.8:** CAN Bus operation with several modules (max. 32, under the standard)



**NOTE**

**If the first or last device in the bus line is not a PME module, a 120 Ω resistor must be connected to each of these external devices.**

**4.5 Synchronization**

Synchronization is recommended when

- the transducer cables of several devices run side by side
- the measuring points are unshielded and are close together

Synchronization prevents differences in the carrier frequency causing disturbing superpositions.



**Fig. 4.9:** Setting synchronization

When synchronizing several modules, **one** device must be declared the master. The other devices must be set as slaves.

Even if modules work without a CAN Bus, the flat ribbon cable should always be used for synchronization between them.

## 5 Setting and operating (MP55)

### 5.1 Operating philosophy

Display in measuring mode:

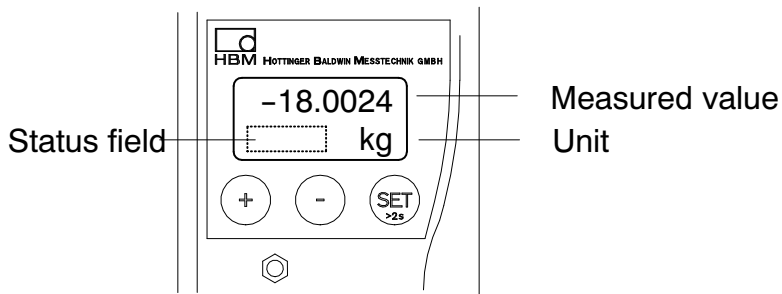

↕ Flashes in the status field if the parameter value can be edited

**The keys  $\oplus$   $\ominus$  are pressure-sensitive:**

Keep key pressed – value runs continuously (press harder to run faster)

Short key press – advance by single value

**Function of the keys:**



1. Change from measuring mode to input mode
2. Choose the first parameter within the group.
3. Confirm the entry
4. Back to measuring range (press for 2 seconds)



Select parameter/group





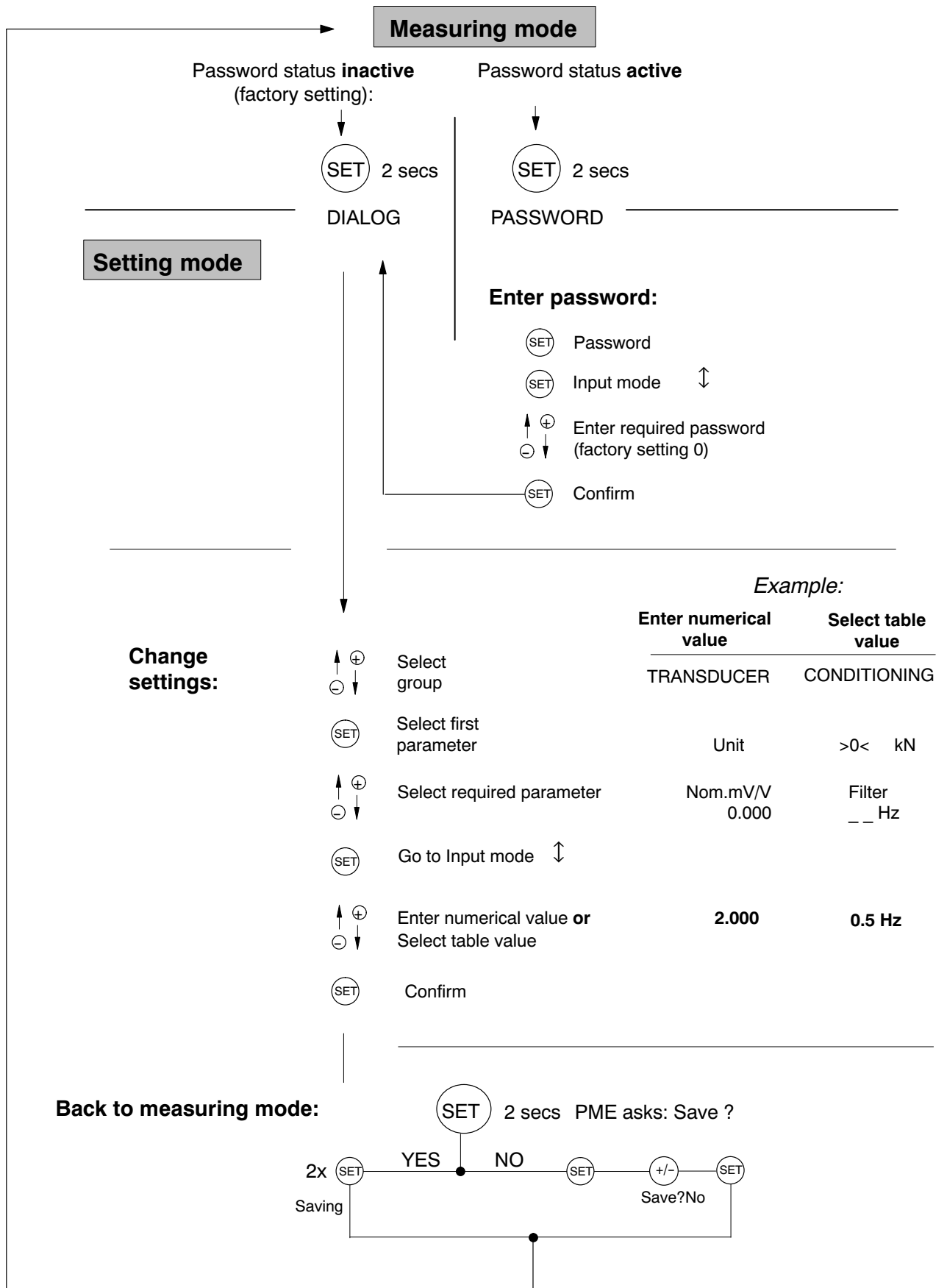





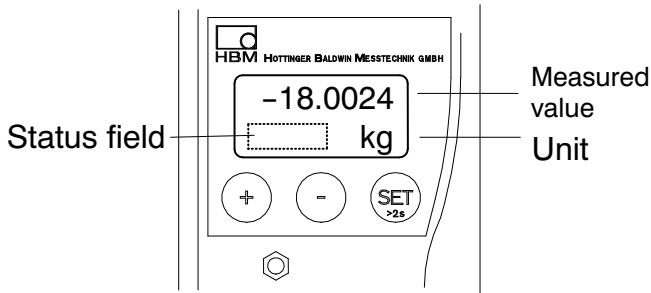

During measurement, if you press ⊕ ⊖, the following will be displayed:

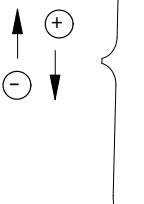
1. display mode
2. status of input and output
3. kinds of error (ERROR)

The symbols !,  and  also appear in the status field.



	Symbol in status field	Display mode
	no character	Gross signal
	>T<	Net signal
		Maximum peak value signal
		Minimum peak value signal
		Peak-to-peak signal
	mV/V	Input signal
	V or mA	Analog output signal
	Output <input checked="" type="checkbox"/> <input type="checkbox"/> <input type="checkbox"/> <input type="checkbox"/> Inpt <input type="checkbox"/> <input type="checkbox"/> <input type="checkbox"/> <input type="checkbox"/>	■ set, □ not set Status of input and output
e.g. StoreMax	<b>Error messages</b> During measurement, the ! character indicates a module error.  In "ERROR" display mode (can be reached with ⊕), the currently occurring errors are automatically displayed one after the other.*)	

Status field	!	An error has occurred
		Standstill state has occurred
		Shunt resistor connected

\*) see chapter 8 "Error messages", page 60

## 5.2 Starting up

- Set the DIP switches as shown in chapter 2 (pages 12 and 13).

Example:

Transducer type and nominal (rated) data	Bridge type	Bridge excitation voltage	Input range
SG force transducer 2 mV/V=20 kN	Full bridge	5 V	3 mV/V
Inductive displ. transducer 80 mV/V	Half bridge	2.5 V	100 mV/V
Inductive displ. transducer 10 mV/V	Half bridge	1 V	15 mV/V
Piezoresistive transducer 400 mV/V	Half bridge	1 V	250 mV/V
Potentiometric transducer 1000 mV/V	Half bridge	2.5 V	1000 mV/V

- Connect the power supply cable and the transducer to the module as described in chapters 4.2 and 4.3.



### CAUTION

**Comply with the safety instructions!**

- Switch on the power supply.

The device performs a function test (about 15 secs) and then, if this runs properly, it is in measuring mode. **During the function test, the control outputs stay at 0 V.**



### NOTE

**If the error message HardwOvf is displayed, please continue reading in chapter 8, “Error messages”.**

In addition to this, the green LED shows you that the MP55 is ready for measurement.

If the LED glows yellow or red, please also continue reading in chapter 8, “Error messages”.



### NOTE

**If you connect transducers in parallel, please note the total resistance that results. If necessary, reduce the excitation voltage.**

## 5.3 Overview of all groups and parameters

<span style="border: 1px solid black; border-radius: 50%; padding: 2px;">SET</span> <span style="border: 1px solid black; border-radius: 50%; padding: 2px;">+</span> <span style="border: 1px solid black; border-radius: 50%; padding: 2px;">-</span> <span style="font-size: 2em;">→</span> <b>Groups</b>												
<span style="border: 1px solid black; border-radius: 50%; padding: 2px;">SET</span>	DIALOG	DATA SET	DISPLAY	TRANSDUCER	TRANSD.-CALIBRAT.	CONDITIONING	ANALOG-OUTPUT	LIMIT VAL. 1...4	PEAK STORE	IN/OUT	CAN-BUS	ADDITION FUNCTION
<span style="border: 1px solid black; border-radius: 50%; padding: 2px;">+</span> Up  <span style="border: 1px solid black; border-radius: 50%; padding: 2px;">-</span> Down  <span style="writing-mode: vertical-rl; transform: rotate(180deg); font-weight: bold;">Parameter overview</span>	Password	Recall ?	DecPoint	Unit	P1Meas.?	>0<set ?	Source Ua	Operatn.	Operatn.	Output1	Baudrate	AmplType
	PassStat	Save ?	Step	Transd.Type	P1 mV/V	>0<kN <sup>1)</sup>	Mode Ua	Source	Input.Min	ModeOut1	Address	PrgVers
	Language	<b>MAINGR</b>	<b>MAINGR</b>	Excitatn	P1 kN <sup>1)</sup>	>0<save	Zero kN <sup>1)</sup>	SwitchDir	InputMax	Output2	Profil	>0<Rf kN <sup>1)</sup>
	I.DataS			Input	P2Meas.?	>T<set ?	Zero V	Value kN <sup>1)</sup>	ClearPkV	ModeOut2	Output	MotionDsp
	I.Displ			ZeromV/V	P2 mV/V	>T<kN <sup>1)</sup>	EndV kN <sup>1)</sup>	Hyst kN <sup>1)</sup>	▽ kN/s <sub>1)</sub>	Output3	OutR. ms	MTime ms
	I.Transd			Zero kN <sup>1)</sup>	P2 kN <sup>1)</sup>	>T<save	EndV V	On Del ms	<b>MAINGR</b>	ModeOut3	PDO-Frmt	MAmp kN <sup>1)</sup>
	I.Calibr			Nom.mV/V	<b>MAINGR</b>	Filter	<b>MAINGR</b>	Off Del ms		Output4	<b>MAINGR</b>	HW Synchr
	I.Condit			NVal kN <sup>1)</sup>		FiltChar		<b>MAINGR</b>		ModeOut4		Keyboard
	I.Analog			Shunt		<b>MAINGR</b>				Zeroing		SNo prior version
	I.LimVal			ShuntPol						Tare		HW-Vers.
	I.PStore			<b>MAINGR</b>						PkMom-Max		<b>MAINGR</b>
	I.I/O									PkHldMax		
	I.CAN									PkMomMin		
	I.AddFnc									PkHldMin		
	<b>MAINGR</b>									ParaCo1		
										ParaCo2		
									InpFunc			
									<b>MAINGR</b>			

■ Preset with DIP switches, **MAINGR** with SET back to group

1) Depending on the unit chosen

### 5.3.1 Setting all parameters

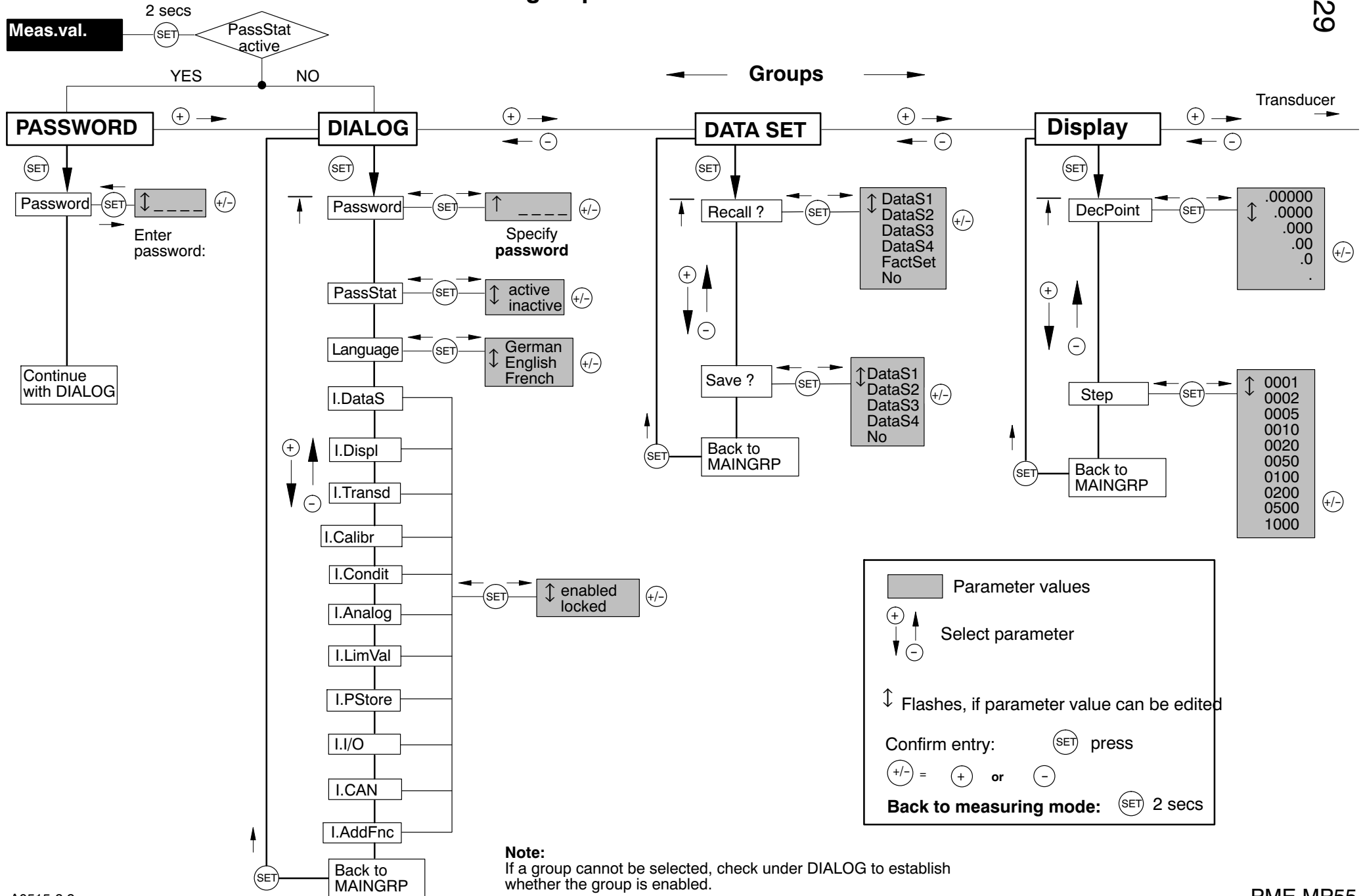

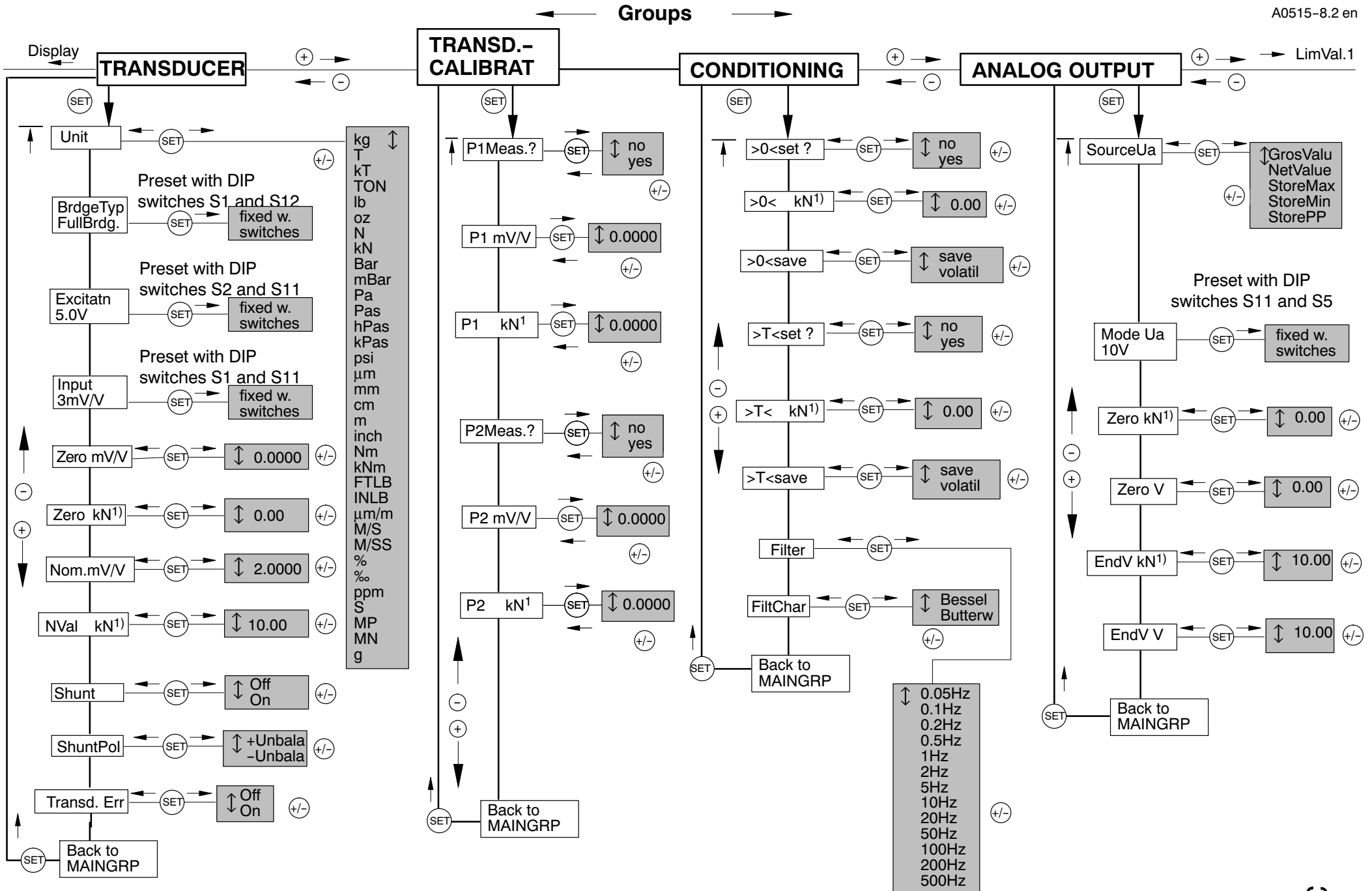

1) Depending on the unit chosen

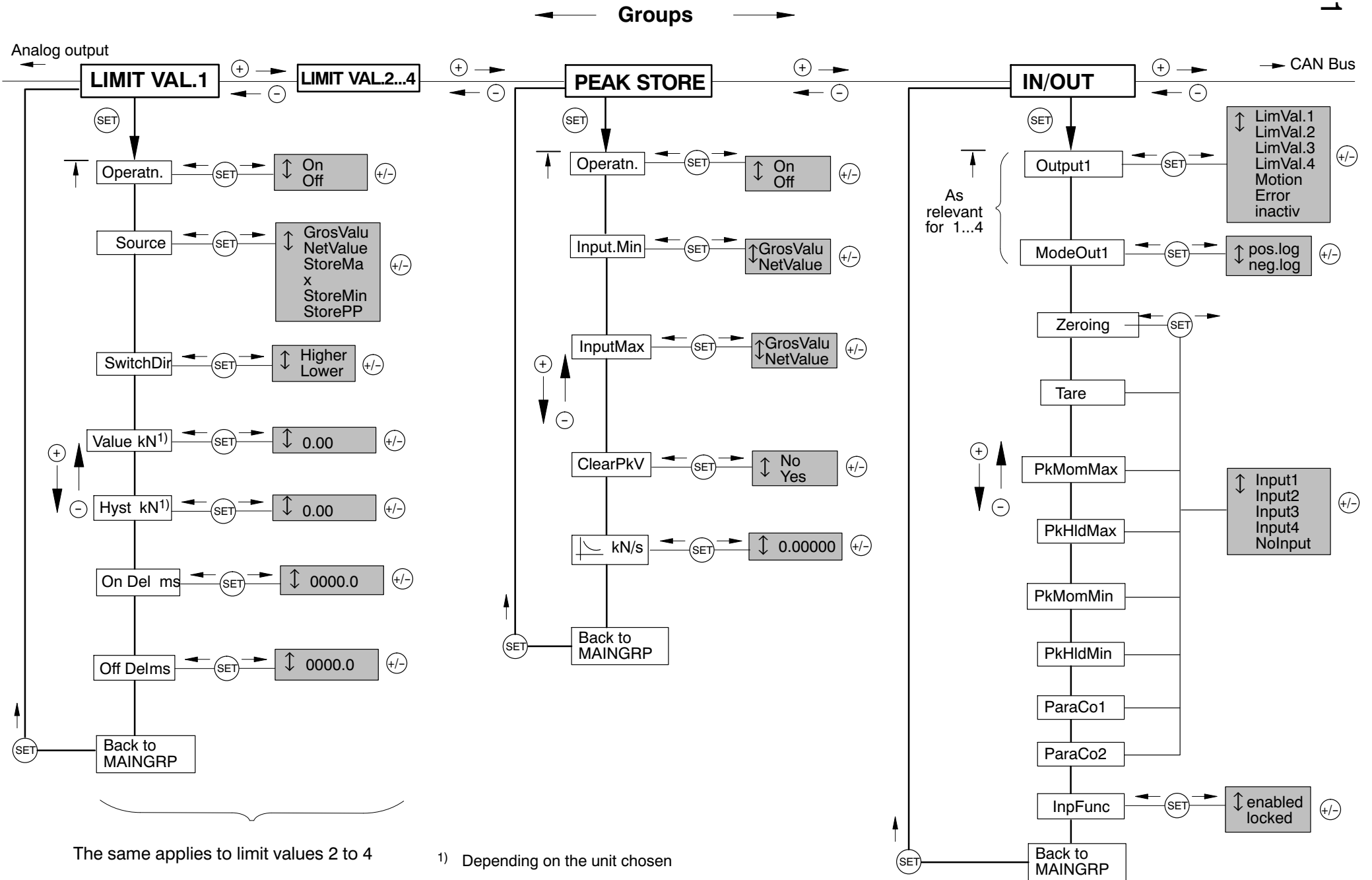

← Groups →

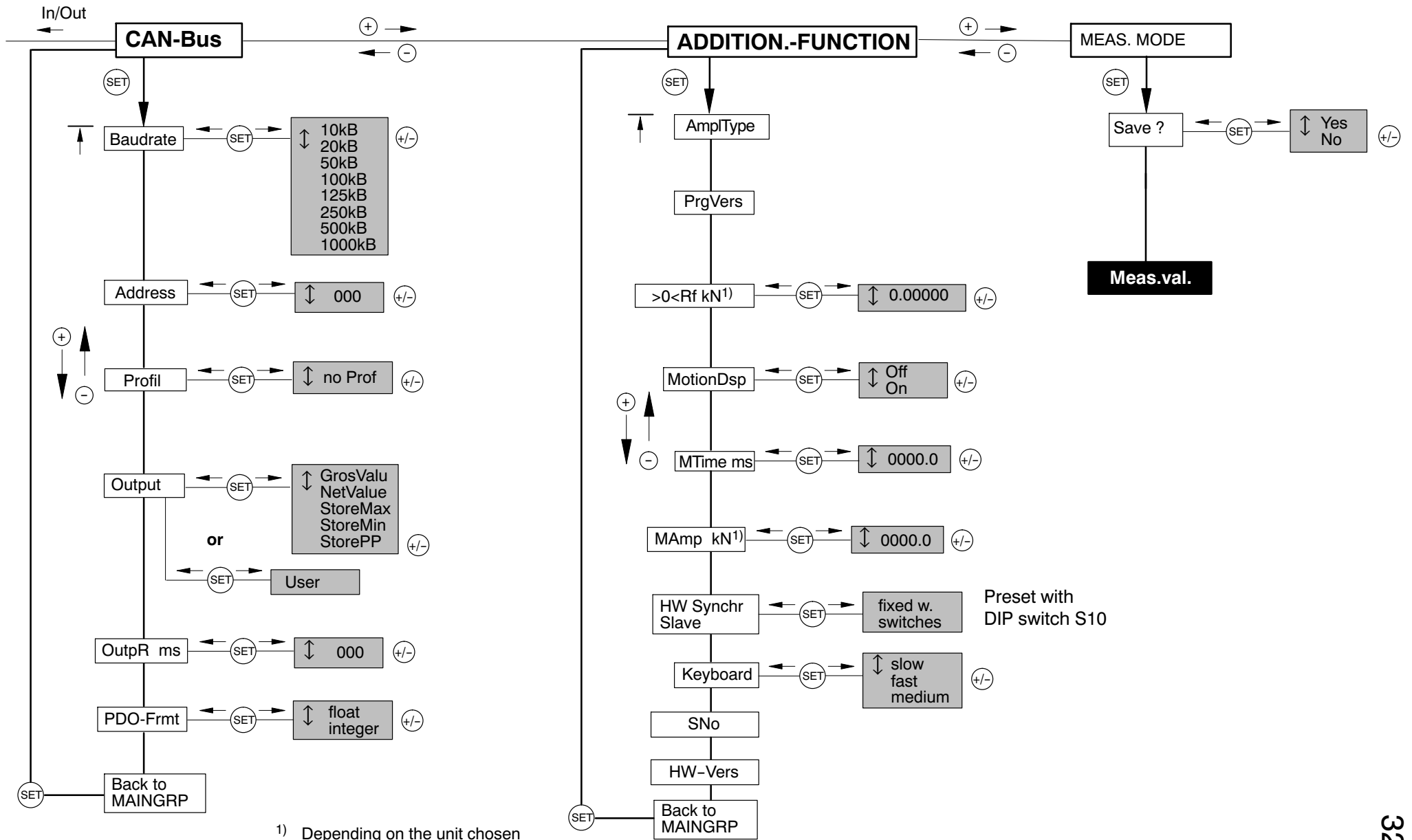

1) Depending on the unit chosen



## 6 Clarification of important parameters

Group	Parameter	Meaning
DIALOG	Password	Specify (change) password, 0000 – 9999 (factory settings password: 0000)
	PassStat	Specify password status: active = password must be entered; inactive = PME can be operated without entering a password
	I.DataS to I.AddFnc	Access to group via keyboard enabled or disabled.

DATA SET	Recall ?	You can either load the factory setting, or one of the four parameter sets that are saved.
	Save ?	All the device settings can be saved power failsafe in four parameter sets. Each time the mode of operation changes from setting to measuring mode, you will be asked whether or not the change is to be saved. The data are permanently protected if you exit setting mode by confirming “Yes” to the protection question.

TRANSDUCER	Zero mV/V Zero kN <sup>1)</sup> Nom.mV/V NVal. kN <sup>1)</sup>	<p><b>Setting up in accordance with transducer characteristics</b></p>

1) Depending on the unit chosen

Group	Parameter	Meaning
TRANSDUCER		<p><b>Scaling information</b></p> <p>Input characteristic:</p> <p>There is a limited range of values for scale factors. Scaling is dependent on the chosen resolution. Settings that cause the respective limits to be exceeded are reported as a “Scaling error” (see page 61).</p> <p>Maximum display resolution: 999 999 digits at 6.67 % of the input measuring range Minimum display resolution: 10 digits at 100 % of the input measuring range</p>
	Shunt ShuntPol	Specifies the polarity of the shunt resistor (positive or negative effect). The misalignment is approx. 1 mV/V with a transducer sensitivity of 2 mV/V and a bridge resistance of 350 Ω. Accuracy approx. 4 %.

<b>TRANSD.-CALIBRAT</b>	P1Meas.? P1 mV/V P1 (physical unit)	Transferring the signals supplied by the transducer at a defined loading  Example: A calibration weight of 4 kg is used to calibrate a 10 kg load cell 1. Relieve load on transducer P1Meas.? YES      0.0457 mV/V P1                      Enter 0 kg (assign physic. unit) 2. Load transducer with 4 kg P2Meas.? YES      0.873 mV/V P2                      Enter 4 kg  <b>Note:</b> If the zero point is modified, P1 and P2 will be discarded.
-------------------------	---	---

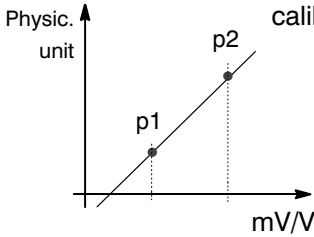

<b>CON-DITIONING</b>		Difference between taring and a zero balance: The zero balance (>0<) affects the gross and the net value. Taring (>T<) only affects the net value.  The difference between a zero balance and taring is made clear in this example:
----------------------	--	---

Weighing steps	Action	Display	
		Gross	Net
Put on the platform (35 kg)	> 0<	before 35 kg after 0 kg	before 35 kg after 0 kg
Put on the container (8 kg)	> T<	before 8 kg after 8 kg	before 8 kg after 0 kg

Group	Parameter	Meaning
<b>CON-DITIONING</b>	>0<kN <sup>1</sup> )	Enter zero value. Zeroing affects the gross and the net value.
	>0<set ?	Trigger zero balance; set current measured value (physical unit) to zero
	>0<save	The zero value is transferred to the EEPROM every time that zeroing occurs (life: 100,000 cycles)
	>T< kN <sup>1</sup> )	Enter tare value. Taring affects the net value.
	>T<set ?	Trigger taring; net value becomes 0
	>T<save	Save tare value immediately after taring

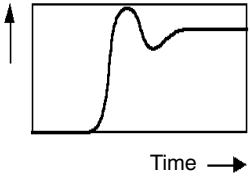
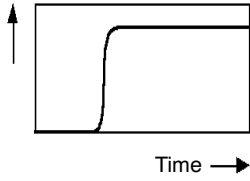
	<p>Filter</p> <p>FiltChar</p>	<table border="0"> <tr> <td>0.05 Hz</td> <td>1 Hz</td> <td>20 Hz</td> <td>500 Hz</td> </tr> <tr> <td>0.1 Hz</td> <td>2 Hz</td> <td>50 Hz</td> <td></td> </tr> <tr> <td>0.2 Hz</td> <td>5 Hz</td> <td>100 Hz</td> <td></td> </tr> <tr> <td>0.5 Hz</td> <td>10 Hz</td> <td>200 Hz</td> <td></td> </tr> </table> <p>Step response</p>  <p>The diagram shows a linear amplitude response with a steep drop above the cut-off frequency. There is an overshoot of approx. 10%.</p> <p>Time →</p> <p>Best frequency response (Butterworth)</p> <p>Step response</p>  <p>The diagram shows a step response with very little (&lt;1 %) or no overshoot. The amplitude response drops less steeply.</p> <p>Time →</p> <p>Best time characteristic (Bessel)</p>	0.05 Hz	1 Hz	20 Hz	500 Hz	0.1 Hz	2 Hz	50 Hz		0.2 Hz	5 Hz	100 Hz		0.5 Hz	10 Hz	200 Hz	
0.05 Hz	1 Hz	20 Hz	500 Hz															
0.1 Hz	2 Hz	50 Hz																
0.2 Hz	5 Hz	100 Hz																
0.5 Hz	10 Hz	200 Hz																

1) Depending on the unit chosen

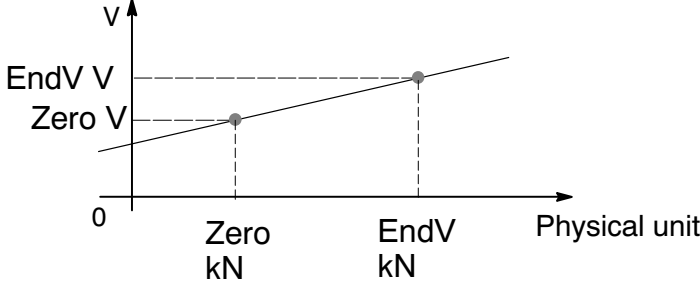
Group	Parameter	Meaning
ANALOG OUTPUT	Source UA	The gross or net value, as well as the peak value, can be chosen as the source of the analog signal.
	Mode UA	Use DIP switches S11 and S5 to specify the signal mode for the analog output. The following options are possible: $\pm 10 \text{ V}$ , $\pm 20 \text{ mA}$ , 4 - 20 mA
	Zero kN <sup>1)</sup> Zero V EndV kN <sup>1)</sup> EndV V	 <p><b>Scaling information</b></p> <p>Output characteristic:</p> <p>The scale factor for the analog output comes from the input and output characteristics. If the set nominal (rated) value corresponds to the measuring range in mV/V, the minimum output voltage that can be set is 0.17 V. Settings that cause the respective limits to be exceeded, are reported as an “Analog scaling error” (see page 61).</p> <p>Analog output scaling range, min.: 0.17 V at 100 % of input measuring range Analog output scaling range, max.: 10 V at 3.67 % of input measuring range</p>

<sup>1)</sup> Depending on the unit chosen

Group	Parameter	Meaning
<b>LIMIT VAL.</b> 1...4	Source	The choice of source for the limit value signal is: gross, net, peak value max/min/peak-to-peak
	SwitchDir Value Hyst	<p>Limit value functions and parameters</p>
	On Del ms	ON delay; when a limit value level is exceeded, the change only takes effect at the output after a delay (On Del).
	Off Del ms	OFF delay, as for On Del

<b>PEAK STORE*)</b>	InputMin/Max	The choice of source for the peak value signal is: gross, net
	ClearPkV	The peak value can be cleared.
	kG/s	<p>The discharge rate of the envelope function (in physical units/sec) for the two peak value stores.</p> <p>Peak value stores can also be used to represent the envelope curve. The envelope function is suitable for measuring amplitude-modulated vibration. The discharge rate (the time constant of the discharge function) defines how quickly the peak value store discharges to the current value.</p>

\*) Also see next page (remote controls)

**Inputs /outputs**

Plug terminal 3: Here there are **4 inputs** available to you for controlling the functions of the PME.

Plug terminal 4: Here there are **4 outputs** available.

Group	Parameter	Meaning	
<b>IN/OUT</b>	Output 1...4	Outputs 1 - 4 can be assigned the following functions: Limit values 1 to 4, standstill, error, inactive	
	Mode Out1...4	The output signal is inverted (pos.log) or not inverted (neg.log).	
		The listed functions can be freely assigned to the remote controls (inputs/outputs).	
	<b>Functions</b>	<b>Input level 0 V</b>	<b>Input level 24 V</b>
	Taring	The transition from 0 V - 24 V starts the taring process	
	Zero balance	The transition from 0 V - 24 V sets the current measurement signal to zero	
	PkMomMax	Peak value operating mode for PkMax	Current value operating mode for PkMax
	PkMomMin	Peak value operating mode for PkMin	Current value operating mode for PkMin
	PkHldMax	PkMax memory contents are updated	PkMax memory contents are frozen
	PkHldMin	PkMin memory contents are updated	PkMin memory contents are frozen
	ParaCo1 ParaCo2	Selecting parameter sets and binary coded inputs	
		Parameter set	ParaCo2
		1	0
		2	0
		3	1
		4	1

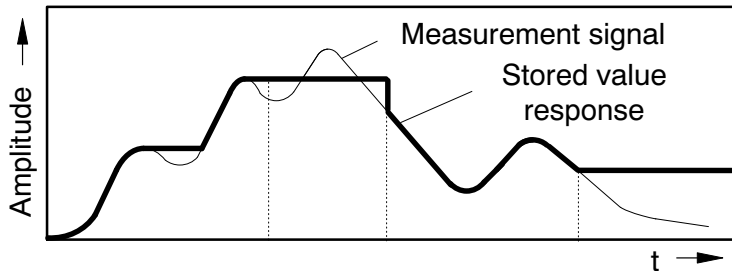
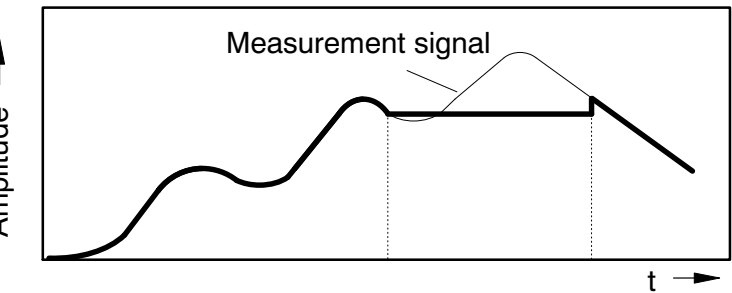
Group	Parameter	Meaning										
<b>IN/OUT</b>	PkMom Max PkMomMin PkHldMax PkHldMax PkHldMin	<p>Peak value operating mode</p>  <table border="1" data-bbox="730 537 1420 627"> <tr> <td>Function</td> <td>Run</td> <td>Hold</td> <td>Run</td> <td>Hold</td> </tr> <tr> <td>Mode of operation</td> <td colspan="2">Peak value (Store1)</td> <td colspan="2">Current value</td> </tr> </table>	Function	Run	Hold	Run	Hold	Mode of operation	Peak value (Store1)		Current value	
		Function	Run	Hold	Run	Hold						
Mode of operation	Peak value (Store1)		Current value									
<p>Current value operating mode</p>  <table border="1" data-bbox="730 1064 1420 1153"> <tr> <td>Function</td> <td>Run</td> <td>Hold</td> <td>Run</td> </tr> <tr> <td>Mode of operation</td> <td colspan="3">Current value</td> </tr> </table>	Function	Run	Hold	Run	Mode of operation	Current value						
Function	Run	Hold	Run									
Mode of operation	Current value											
<b>CAN-Bus</b>	Baud rate	10 kB, 20 kB, 50 kB, 100 kB, 125 kB, 250 kB, 500 kB, 1000 kB										
	Address	From 0 to 127 (8 bit)										
	Profile	DS401 (Device Profile for I/O Modules) or DS404 (Device Profile for Measuring Devices and Closed Loop Controller)										
	Output	You choose the signal to be output over the CAN Bus: gross, net or max/min peak value.										
	OutR. ms	Output rate. Indicates the timing interval (in ms) for the value to be sent over the CAN interface.										

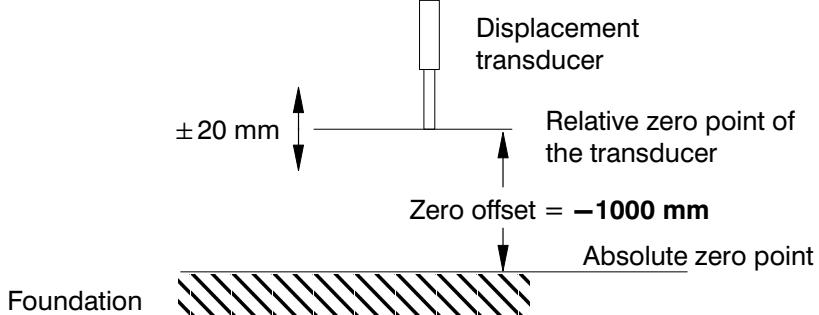
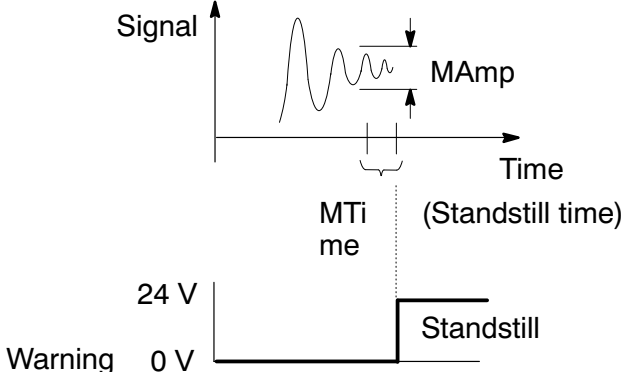
Group	Parameter	Meaning
<p><b>ADD. FUNCTION</b></p>	<p>&gt;0&lt;Rf</p>	<p>Reference zero</p> <p>A displacement transducer (<math>\pm 20</math> mm nominal (rated) displacement) is mounted at a height of 1 m, measured from the foundation. When zeroing, the <i>analog output</i> is adjusted to 0 V. The <i>display value</i> is adjusted to &gt;0&lt;Ref (+1000 mm). The possible display range is 980 mm to 1020 mm.</p> 
	<p>MotionDsp</p>	<p>Standstill indication. If standstill occurs with ON selected, the following character is displayed</p>
<p>MTime ms MAmp kg</p>		<p>Standstill time; Standstill is reported if amplitude MAmp is not exceeded in standstill time "t".</p> 



## 7 CAN interface description

### 7.1 General

The MP55 module has a built-in CAN interface, which can be used both for transmitting measured values and for module parameterization. Different baud rates can be selected up to a maximum of 1 Mbaud. The interface protocol is adapted from the CANopen Standard.

### 7.2 Cyclic transmission of measured values

The cyclic data are transmitted as so-called “Process Data Objects” (PDOs, in accordance with CANopen definitions). Interesting measured values are transmitted cyclically from the measurement module under a previously defined CAN Identifier, without any further identification. A query message is not required. A parameter setting determines how often the PDOs are transmitted (see object dictionary). Data formats longer than one byte are always transmitted in LSB-MSB order.

#### Transmit PDO:

CAN identifier	384 (180 Hex) + module address
Data bytes 1...4	Measured value (LSB-MSB), integer 32
5th data byte	Status (object 2010)

#### Receive PDO:

CAN identifier	512 (200 Hex) + module address
1st data byte	Control word (object 2630)

As well as these pre-defined PDOs, others can be set up in accordance with CANopen definitions (CiA-DS 301) via so-called mapping. Appropriate tools are available on the market.

The exchange of cyclic PDOs only starts once the module has been brought to the “Operational” state. This is done by the “Start\_Remote\_Node” message

CAN identifier	0
1st data byte	1
2nd data byte	Module address (0 = all)

The message “Enter\_Pre\_Operational\_State” can be used to exit the “Operational” state:

CAN identifier	0
1st data byte	128
2nd data byte	Module address (0 = all)

## 7.3 Parameterization

Messages for module parameterization are transmitted as so-called “Service Data Objects”(SDOs, in accordance with CANopen definitions). The various parameters are addressed by an index number and a sub-index number. For the assignment of these index numbers, please refer to the object dictionary. Data formats longer than one byte are always transmitted in LSB-MSB order.

### Reading a parameter:

Query (PC or PLC to MP55)

CAN identifier	1536 (600 Hex) + module address
1st data byte	64 (40 Hex)
2nd + 3rd data byte	Index (LSB_MSB)
4th data byte	Sub-index
5th - 8th data byte	0

Response (MP55 to PC or PLC)

CAN identifier	1408 (580 Hex) + module address
1st data byte	66 (42Hex)
2nd + 3rd data byte	Index (LSB-MSB)
4th data byte	Sub-index
5th - 8th data byte	Value (LSB-MSB)

### Writing a parameter:

Transmit value (PC or PLC to MP55)

CAN identifier	1536 (600 Hex) + module address
1st data byte	47 (2FHex) = write 1 byte 43 (2BHex) = write 2 bytes 35 (23Hex) = write 4 bytes)
2nd + 3rd data byte	Index (LSB-MSB)
4th data byte	Sub-index
5th - 8th data byte	Value (LSB-MSB)

## Acknowledgement (MP55 to PC or PLC)

CAN identifier	1408 (580 Hex) + module address
1st data byte	96 (60Hex)
2nd + 3rd data byte	Index (LSB_MSB)
4th data byte	Sub-index
5th – 8th data byte	0

**Response in the event of an error when reading or writing parameters:**

## Error acknowledgement (MP55 to PC or PLC)

CAN identifier	1408 (580 Hex) + module address
1st data byte	128 (80 Hex)
2nd + 3rd data byte	Index (LSB_MSB) or 0
4th data byte	Sub-index or 0
5th – 6th data byte	Additional error code: 10H: Parameter value invalid 11H: Sub-index does not exist 12H: Length too great 13H: Length too small 20H: Service cannot be executed at present 21H: – because of local checking 22H: – because of device status 30H: Parameter value range overflow 31H: Parameter value too big 32H: Parameter value too small 40H: Value incompatible with other settings 41H: Data cannot be mapped 42H: PDO length overflow 43H: General incompatibility
7th data byte	Error code: 1: Object access not supported 2: Object does not exist 3: Parameter inconsistent 4: Illegal parameter 6: Hardware error 7: Type conflict 9: Object attribute inconsistent (sub-index does not exist)
8th data byte	Error class: 5: Service faulty 6: Access error 8: Other errors

## 7.4 Object dictionary: Communication profile range in accordance with CANopen (CiA-DS301)

Index (Hex)	Sub-index	Name	Data type	Attr.	Values
1000	0	Device type	Unsigned32	ro	
1001	0	Error register	Unsigned8	ro	Bit 0: Fatal error Bit 4: Communication error Bit 7: Manufacturer-specific
1003	0	Pre-defined error array	Unsigned8	rw	Number of errors
1003	1..7	Pre-defined error array	Unsigned32	ro	Bytes 1-2: Error code Bytes 3-4: Additional information
1005	0	SYNC message identifier	Unsigned32	rw	
1008	0	Manufacturer device name	Visible string	ro	
1009	0	Manufacturer hardware version	Visible string	ro	
100A	0	Manufacturer software version	Visible string	ro	
100B	0	Device address	Unsigned32	ro	
100C	0	Guard time	Unsigned16	rw	
100D	0	Life time factor	Unsigned8	rw	
100E	0	Node guarding identifier	Unsigned32	rw	
100F	0	Number of supported SDOs	Unsigned32	ro	
1010	0..2	Save communication parameters	Unsigned32	rw	65766173Hex
1011	0..2	Load communication parameters factory settings	Unsigned32	rw	64616F6CHex
1012	0..2	Time stamp identifier	Unsigned32	rw	
1014	0	EMERGENCY message identifier	Unsigned32	rw	
1200	0..2	Server SDO parameter	SDO parameter	ro	
1400	0..2	1st Receive PDO parameter	PDOComm-Par	rw	
1401	0..2	2nd Receive PDO parameter	PDOComm-Par	rw	
1600	0..2	1st Receive PDO mapping	PDOMapping	rw	
1601	0..2	2nd Receive PDO mapping	PDOMapping	rw	

Index (Hex)	Sub-index	Name	Data type	Attr.	Values
1800	0..2	1st Transmit PDO parameter	PDOComm-Par	rw	
1801	0..2	2nd Transmit PDO parameter	PDOComm-Par	rw	
1A00	0..2	1st Transmit PDO mapping	PDOMapping	rw	
1A01	0..2	2nd Transmit PDO mapping	PDOMapping	rw	

### Data structures:

#### PDO CommPar:

Index	Sub-index	Name	Data type
0020	0	Number of entries	unsigned8
	1	CAN Identifier of the PDO	unsigned32
	2	Transmission type	unsigned8
	3	Lockout time	unsigned16
	4	Priority group	unsigned8

#### CAN Identifier of the PDO (sub-index 1):

Bits	Value	Meaning
31 (MSB)	0	PDO valid
	1	PDO invalid
30	0	RTR allowed
	1	RTR not allowed
29	0	11-bit ID
	1	29-bit ID
28..0	X	CAN ID

#### PDO mapping:

Index	Sub-index	Name	Data type
0021	0	Number of mapped objects	unsigned8
	1	1st mapped object	unsigned32
	2	2nd mapped object	unsigned32
	...	...	unsigned32

#### Structure of a PDO mapping entry:

Index (16 bits)	Sub-index (8 bits)	Object length in bits (8bit)
-----------------	--------------------	------------------------------

SDO parameters:

Index	Sub-index	Name	Data type
0022	0	Number of entries	unsigned8
	1	COB ID client->server	unsigned32
	2	COB ID server->client	unsigned32
	3	Node ID (optional)	unsigned8

Error code (object 1003HEX):

Value	Meaning
0	No error
1000	Fatal error
8100	Communication
FF00	Device-specific

Error code - additional information (object 1003Hex):

Value	Meaning
0	No error
1	Transmission error
2	System error
3	Unknown command
4	Incorrect number of parameters
5	Incorrect parameter value
6	Error on account of filter frequency
7	Amplifier overloaded
8	Command cannot be executed
10	Incorrect channel selection
11	Measuring error
12	Triggering error
13	Measuring range error
14	Taring error
21	Warning on account of filter frequency
22	Warning on account of tare status

## 7.5 Object dictionary: manufacturer-specific objects

Parameters that make reference to measured values are scaled true to number, coded as Long (32-bit integer). The position of the decimal point is defined in object 2120 Hex. Alternatively, these quantities are also available as Float values (IEEE754-1985 32-bit format). See page 56.

Index (Hex)	Sub-index	Name	Format	Attr.	Values
		<b>Measured values:</b>			
2000	1	Gross measured value	integer32	rop	
2001	1	Net measured value	integer32	rop	
2002	1	Maximum	integer32	rop	
2003	1	Minimum	integer32	rop	
2004	1	Peaktpeak	integer32	rop	
2005	1	Measured value in mV/V	integer32	ro	5 Decimal places
2006	1	Analog output value V	integer32	ro	3 Decimal places
2010	1	Measured value status	unsigned8	rop	Bit 0: Meas. val. over flow Bit 1: Analog out. overfl. Bit 2: Incorrect scaling Bit 3: EEPROM error Bits 4 - 7: Limit values 1 - 4
2011	1	Measured value status_2	unsigned32	rop	Bit 0: Hardware overfl. Bit 1: ADC overfl. Bit 2: Gross overfl. Bit 3: Net overfl. Bit 4: Analog out. overfl. Bit 5: Maximum overfl. Bit 6: Minimum overfl. Bit 7: Negative overfl. Bit 8: Limit value 1 Bit 9: Limit value 2 Bit 10: Limit value 3 Bit 11: Limit value 4 Bit 12: Input scaling Bit 13: Output scaling Bit 14: Nom. val. exceeded. Bit 15: Urcal.Error Bit 16: Transducer error Bit 17: CAN Bus OFF Bit 18: CAN Tx error Bit 21: Standstill recognition
2020	1	Input/output status	unsigned8	rop	Bits 0 - 3: Outputs 1 - 4 Bits 4 - 7: Inputs 1 - 4

Index (Hex)	Sub-index	Name	Format	Attr	Values
2080	0	Edit mode	unsigned8	ro	1: Edit mode on 0: Edit mode off
2081	0	Restart executed	unsigned8	rw	1: Restart executed 0: Write = Delete
2082	0	Serial number	visible string	ro	12 char.
2083	0	Exit edit mode	unsigned8	wo	Measurement display with assigned value after writing

<b>Dialog:</b>					
2101	0	Dialog language	unsigned16	rw	1500 German 1501 English
2103	0	Password	integer16	rw	
2104	1	Enable keyboard and menu	unsigned16	rw	0: Enable input 1: Input disabled Bit 0: Password entry Bit 1: Dialog Bit 2: Parameter set Bit 3: Display Bit 4: Transducer Bit 5: Conditioning Bit 6: Analog output Bit 7: Limit values Bit 8: Peak values Bit 9: Inputs/outputs Bit 10: CAN Bit 11: Additional functions Bit 15: Keyboard lock
<b>Parameter sets</b>					
2110	1	Activate parameter set	unsigned16	rw	6600: Factory settings 6601: Parameter set 1 6602: Parameter set 2 6603: Parameter set 3 6604: Parameter set 4
2111	1	Save parameter set	unsigned16	rw	see above
2112	1	Number of the active parameter set	unsigned16	ro	see above



Index (Hex)	Sub-index	Name	Format	Attr.	Values
		<b>Display adaptation</b>			
2120	1	Decimal point position	unsigned16	rw	0..5
2121	1	Increment	unsigned16	rw	110: 1 111: 2 112: 5 113: 10 114: 20 115: 50 116: 100 117: 200 118: 500 119: 1000
		<b>Transducers</b>			
2122	1	Physical unit	unsigned16	rw	1603: g 1604: kg 1605: T 1606: kT 1607: TON 1608: lb 1609: oz 1610: N 1611: kN 1612: bar 1613: mbar 1614: Pa 1615: Pas 1616: hPas 1617: kPas 1618: psi 1619: μm 1620: mm 1621: 0 cm 1622: m 1623: inch 1624: Nm 1625: kNm 1626: FTLB 1627: INLB 1628: μm/m 1629: m/s 1630: m/s <sup>2</sup> 1631: percentage 1632: mill 1633: ppm 1634: S 1635: MPas 1636: MN 1637: Blank spaces

Index (Hex)	Sub-index	Name	Format	Attr.	Values
2130	1	Transducer type	unsigned16	ro	350: Full bridge 351: Half bridge 380: LVDT
2131	1	Excitation	unsigned16	ro	11: 1 V 13: 2.5 V 14: 5 V
2132	1	Measuring range	unsigned16	ro	for $U_B = 5\text{ V}$ 700: 3 mV/V 773: 50 mV/V 703: 500 mV/V for $U_B = 2.5\text{ V}$ 771: 6 mV/V 774: 100 mV/V 776: 1000 mV/V for $U_B = 1\text{ V}$ 772: 15 mV/V 775: 250 mV/V 777: 2500 mV/V
2133	1	Shunt	unsigned16	rw	1: On 0: Off
2134	1	Shunt misalignment direction	unsigned16	rw	44: positive 45: negative
2140	1	Transducer zero mV/V	integer32	rw	Value in mV/V
2141	1	Transducer zero phys. unit	integer32	rw	Value e.g. in kN
2142	1	Transducer sensitivity mV/V	integer32	rw	Value in mV/V
2143	1	Transducer nom. value phys. unit	integer32	rw	Value e.g. in kN
2150	1	Input characteristic point 1, mV/V	integer32	rw	Value in mV/V
2151	1	Input characteristic point 2, mV/V	integer32	rw	Value in mV/V
2160	1	Input characteristic point 1, phys. unit	integer32	rw	Value e.g. in kN
2161	1	Input characteristic point 2, phys. unit	integer32	rw	Value e.g. in kN

Index (Hex)	Sub-index	Name	Format	Attr.	Values
		<b>Conditioning</b>			
2180	1	Tare value	integer32	rw	
2181	1	Zero balance value	integer32	rw	
2182	1	Taring storage mode	unsigned16	rw	6611: volatile 6610: permanent
2183	1	Zeroing storage mode	unsigned16	rw	6611: volatile 6610: permanent
2185	1	Zero reference	integer32	rw	
2190	1	Filter frequency	unsigned16	rw	908: 0.05 Hz 914: 0.1 Hz 917: 0.2 Hz 921: 0.5 Hz 927: 1 Hz 931: 2 Hz 935: 5 Hz 941: 10 Hz 945: 20 Hz 949: 50 Hz 955: 100 Hz 958: 200 Hz 962: 500 Hz
2191	1	Filter characteristics	unsigned16	rw	141: Butterworth 142: Bessel
21A0	1	Standstill monitoring time window	unsigned32	rw	ms
21A1	1	Standstill monitoring amplitude	integer32	rw	Value e.g. in kN
21A2	1	Activate standstill indication	unsigned16	rw	1: on 0: off
		<b>Analog output</b>			
21C0	1	Analog output mode (voltage/current)	unsigned16	ro	290: $\pm 10$ V 291: $\pm 20$ mA 292: 4 – 20 mA
21C1	1	Signal at analog output	unsigned16	rw	214: Gross 215: Net 204: Max 205: Min 218: Peaktopeak
21D0	1	Analog output zero point, phys. unit	integer32	rw	Value e.g. in kN
21D1	1	Analog output end value, phys. unit	integer32	rw	Value e.g. in kN
21D2	1	Analog output zero point, V	integer32	rw	Value in V
21D3	1	Analog output end value, V	integer32	rw	Value in V

Index (Hex)	Sub-index	Name	Format	Attr.	Values
		<b>Limit value switches</b>			
2210	1	Limit value 1 enable	unsigned16	rw	1: yes 0: no
2211	1	Limit value 1 input signal	unsigned16	rw	214: Gross 215: Net 204: Min 205: Max 218: Peaktpeak
2212	1	Limit value 1 direction	unsigned16	rw	130: Overshooting 131: Undershooting
2214	1	Limit value 1 ON delay	integer32	rw	ms
2215	1	Limit value 1 OFF delay	integer32	rw	ms
2216	1	Limit value 1 switching level	integer32	rwp	
2217	1	Limit value 1 hysteresis	integer32	rw	
2218	1	Limit value 1 status	unsigned8	ro	
2220	1	Limit value 2 enable	unsigned16	rw	1: yes 0: no
2221	1	Limit value 2 input signal	unsigned16	rw	214: Gross 215: Net 204: Min 205: Max 218: Peaktpeak
2222	1	Limit value 2 direction	unsigned16	rw	130: Overshooting 131: Undershooting
2224	1	Limit value 2 ON delay	integer32	rw	ms
2225	1	Limit value 2 OFF delay	integer32	rw	ms
2226	1	Limit value 2 switching level	integer32	rwp	
2227	1	Limit value 2 hysteresis	integer32	rw	
2228	1	Limit value 2 status	unsigned8	ro	
2230	1	Limit value 3 enable	unsigned16	rw	1: yes 0: no
2231	1	Limit value 3 input signal	unsigned16	rw	214: Gross 215: Net 204: Min 205: Max 218: Peaktpeak
2232	1	Limit value 3 direction	unsigned16	rw	130: Overshooting 131: Undershooting

Index (Hex)	Sub-index	Name	Format	Attr.	Values
2234	1	Limit value 3 ON delay	integer32	rw	ms
2235	1	Limit value 3 OFF delay	integer32	rw	ms
2236	1	Limit value 3 switching level	integer32	rwp	
2237	1	Limit value 3 hysteresis	integer32	rw	
2238	1	Limit value 3 status	unsigned8	ro	
2240	1	Limit value 4 enable	unsigned16	rw	1: yes 0: no
2241	1	Limit value 4 input signal	unsigned16	rw	214: Gross 215: Net 204: Min 205: Max 218: Peaktopeak
2242	1	Limit value 4 direction	unsigned16	rw	130: Overshooting 131: Undershooting
2244	1	Limit value 4 ON delay	integer32	rw	ms
2245	1	Limit value 4 OFF delay	integer32	rw	ms
2246	1	Limit value 4 switching level	integer32	rwp	
2247	1	Limit value 4 hysteresis	integer32	rw	
2248	1	Limit value 4 status	unsigned8	ro	
		<b>Peak values</b>			
2260	1	Min store input signal	unsigned16	rw	214: Gross 215: Net
2261	1	Max store input signal	unsigned16	rw	214: Gross 215: Net
2262	1	Envelope curve discharge	integer32	rw	Display / s
2263	1	Enable peak-value store	unsigned16	rw	1: enable 2: locked
		<b>Additional functions</b>			
2271	0	Hardware synchronization	unsigned16	ro	6700: Master 6701: Slave

Index (Hex)	Sub-index	Name	Format	Attr.	Values
		<b>Digital inputs/outputs</b>			
2310	1	Output 1 function	unsigned16	rw	200: no function 221: Limit value 1 222: Limit value 2 223: Limit value 3 224: Limit value 4 230: Error / warning 231: Standstill
2311	1	Output 1 mode	unsigned16	rw	135: normal 136: inverse
2312	1	Output 2 function	unsigned16	rw	see above
2313	1	Output 2 mode	unsigned16	rw	see above
2314	1	Output 3 function	unsigned16	rw	see above
2315	1	Output 3 mode	unsigned16	rw	see above
2316	1	Output 4 function	unsigned16	rw	see above
2317	1	Output 4 mode	unsigned16	rw	see above
2320	1	Remote function Taring	unsigned16	rw	100: No input 101: Input 1 102: Input 2 103: Input 3 104: Input 4
2322	1	Remote function Max-/current value	unsigned16	rw	see above
2323	1	Remote function Min-/current value	unsigned16	rw	see above
2324	1	Remote function Hold max value	unsigned16	rw	see above
2325	1	Remote function Hold min value	unsigned16	rw	see above
2326	1	Remote function Zeroing	unsigned16	rw	see above
2327	1	Remote function Parameter set selection 1	unsigned16	rw	see above
2328	1	Remote function Parameter set selection 2	unsigned16	rw	see above
2330	1	Enable remote contacts	unsigned16	rw	5: enabled 4: locked

Index (Hex)	Sub-index	Name	Format	Attr.	Values
		<b>CAN interface</b>			
2400	0	Baud rate in CAN	unsigned16	rw	1409: 10 kBaud 1411: 20 kBaud 1413: 50 kBaud 1427: 100 kBaud 1417: 125 kBaud 1419: 250 kBaud 1421: 500 kBaud 1424: 1000 kBaud
2410	1	PDO contents	unsigned16	rw	214: Gross 215: Net 204: Max 205: Min 218: Peaktopeak 219: User
2411	1	Transmission rate for measured values	integer32	rw	0.1 ms
2412	1	Measured value format	unsigned16	rw	1253: Integer32 1257: Float

		<b>Functions</b>			
2600	1	Set zero	unsigned8	wo	1: Zeroing
2610	1	Taring	unsigned8	wo	1: Taring
2620	1	Clear Max store	unsigned8	wo	1: continuous clear; 2: 1x delete
2621	1	Clear Min store	unsigned8	wo	1: continuous clear 2: 1x delete
2622	1	Hold Max store	unsigned8	rwp	1: Hold
2623	1	Hold Min store	unsigned8	rwp	1: Hold
2630	1	Control word	unsigned8	rw	Bit 0: Zeroing Bit 1: Taring Bit 4: Clear Max. Bit 5: Clear Min. Bit 6: Hold Max. Bit 7: Hold Min.

## 7.6 Manufacturer-specific objects in FLOAT data format

Index (Hex)	Sub-index	Name	Format	Attr.	Values
		<b>Measured values:</b>			
3000	1	Gross measured value	float	rop	
3001	1	Net measured value	float	rop	
3002	1	Maximum	float	rop	
3003	1	Minimum	float	rop	
3004	1	Peaktotpeak	float	rop	
3005	1	Measured value in mV/V	float	ro	
3006	1	Analog output value	float	ro	
		<b>Transducers</b>			
3140	1	Transducer zero mV/V	float	rw	Value in mV/V
3141	1	Transducer zero physical unit	float	rw	Value e.g. in kN
3142	1	Transducer sensitivity mV/V	float	rw	Value in mV/V
3143	1	Transducer nom. (rated) value physical unit	float	rw	Value e.g. in kN
3150	1	Input characteristic point 1, mV/V	float	rw	
3151	1	Input characteristic point 2, mV/V	float	rw	
3160	1	Input characteristic point 1, phys. unit	float	rw	
3161	1	Input characteristic point 2, phys. unit	float	rw	
		<b>Conditioning</b>			
3180	1	Tare value	float	rw	
3181	1	Zero balance value	float	rw	
3185	1	Zero reference	float	rw	
31A1	1	Standstill monitoring amplitude	float	rw	
		<b>Analog output</b>			
31D0	1	Analog output zero point, phys. unit	float	rw	
31D1	1	Analog output end value, phys. unit	float	rw	
31D2	1	Analog output zero point, V	float	rw	
31D3	1	Analog output end value, V	float	rw	



Index (Hex)	Sub-index	Name	Format	Attr.	Values
		<b>Limit value switches</b>			
3216	1	Limit value 1 switching level	float	rwp	
3217	1	Limit value 1 hysteresis	float	rw	
3226	1	Limit value 2 switching level	float	rwp	
3227	1	Limit value 2 hysteresis	float	rw	
3236	1	Limit value 3 switching level	float	rwp	
3237	1	Limit value 3 hysteresis	float	rw	
3246	1	Limit value 4 switching level	float	rwp	
3247	1	Limit value 4 hysteresis	float	rw	
		<b>Peak values</b>			
3262	1	Envelope curve discharge	float	rw	Display value/s

## 7.7 Examples

### Example 1:

Reading the net measured value as a float value via SDO transfer from the amplifier with module address 3.

Protocol to the amplifier:

Identifier	Byte 1	Byte 2	Byte 3	Byte 4	Byte 5	Byte 6	Byte 7	Byte 8
<b>0603</b>	<b>40</b>	<b>01</b>	<b>30</b>	<b>01</b>	<b>X</b>	<b>X</b>	<b>X</b>	<b>X</b>
CAN identifier	Read	Index low byte	Index high byte	Sub-index	don't care			

Response from amplifier:

Identifier	Byte 1	Byte 2	Byte 3	Byte 4	Byte 5	Byte 6	Byte 7	Byte 8
<b>0583</b>	<b>43</b>	<b>01</b>	<b>30</b>	<b>01</b>	<b>m0</b>	<b>m1</b>	<b>m2</b>	<b>m3</b>
CAN identifier	Read acknowledgement	Index low byte	Index high byte	Sub-index	Low byte	Measured value as float		High byte

### Example 2:

Setting the filter frequency to 200 Hz.

Protocol to the amplifier:

Identifier	Byte 1	Byte 2	Byte 3	Byte 4	Byte 5	Byte 6	Byte 7	Byte 8
<b>0603</b>	<b>2B</b>	<b>90</b>	<b>21</b>	<b>01</b>	<b>BB</b>	<b>03</b>	<b>X</b>	<b>X</b>
CAN identifier	Write 2 bytes	Index low byte	Index high byte	Sub-index	Low byte	High byte	don't care	
					958 = (03BB Hex)			

Response from amplifier:

Identifier	Byte 1	Byte 2	Byte 3	Byte 4	Byte 5	Byte 6	Byte 7	Byte 8
<b>0583</b>	<b>60</b>	<b>90</b>	<b>21</b>	<b>01</b>	<b>X</b>	<b>X</b>	<b>X</b>	<b>X</b>
CAN identifier	Write acknowledgement	Index low byte	Index high byte	Sub-index	don't care			

**Example 3:**

The tare value is to be set to 23.250 kg (transfer as a long value, i.e. 23.250 =23250).

Assumed settings: unit “kg”, decimal places: 3

Protocol to the amplifier:

Identifier	Byte 1	Byte 2	Byte 3	Byte 4	Byte 5	Byte 6	Byte 7	Byte 8
<b>0603</b>	<b>23</b>	<b>80</b>	<b>21</b>	<b>01</b>	<b>D2</b>	<b>5A</b>	<b>00</b>	<b>00</b>
CAN identifier	Write 4 bytes	Index low byte	Index high byte	Sub-index	Low byte 23.250 kg=23500(=5AD2Hex)			High byte

Response from amplifier:

Identifier	Byte 1	Byte 2	Byte 3	Byte 4	Byte 5	Byte 6	Byte 7	Byte 8
<b>0583</b>	<b>60</b>	<b>80</b>	<b>21</b>	<b>01</b>	<b>X</b>	<b>X</b>	<b>X</b>	<b>X</b>
CAN identifier	Write acknowledgement	Index low byte	Index high byte	Sub-index	don't care			

## 8 Error messages/operating state (LED)

Depending on the display mode, various error messages can appear on the display instead of the measured value:

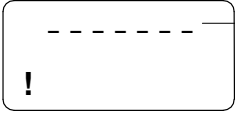
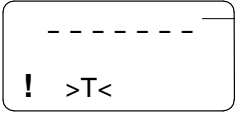
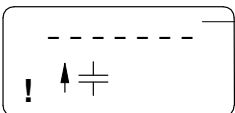
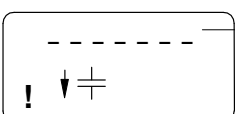
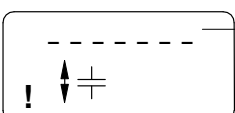
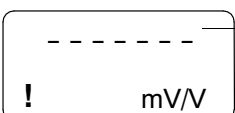
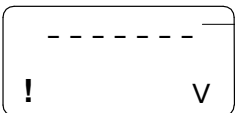
Signal status (mode)	Possible error message			
 <p><b>Gross</b></p>	HrdwOvfl	ADC+Ovf ADC-Ovf	<i>Grs+Ovfl</i> <i>Grs-Ovfl</i>	Scal.Err UrCalErr
 <p><b>Net</b></p>	HrdwOvfl	ADC+Ovf ADC-Ovf	<i>Net+Ovfl</i> <i>Net-Ovfl</i>	Scal.Err UrCalErr
 <p><b>Max. peak value signal</b></p>	<i>PkMaxOvf</i>	UrCalErr	} When activated	
 <p><b>Min. peak value signal</b></p>	<i>PkMinOvf</i>	UrCalErr		
 <p><b>Peak-to-peak signal</b></p>	<i>PkPk Ovf</i>	UrCalErr		
 <p><b>Input signal</b></p>	HrdwOvfl	ADC+Ovf ADC-Ovf	UrCalErr	
 <p><b>Analog output signal</b></p>	HrdwOvfl	ADC+Ovf ADC-Ovf	<i>AnlgOvfl</i> <i>AScalErr</i>	UrCalErr

Current errors are displayed continuously (also see page 26). Press ⊕, until you arrive at “ERROR” display mode.

Error message	Cause	Remedy
Hrdware <sup>1)</sup> (HrdwOvfl) <sup>2)5)</sup>	Input signal overflow Transducer not connected Incorrect transducer connection Amplifier does not match transducer type No sense leads connected	Connect transducers, see pin assignment on page 19 Adapt the amplifier under the TRANSDUCER group Connect sense leads
AD Conv <sup>5)</sup> (ADC+Ovfl, ADC-Ovfl)	Input signal of A/D converter too big	Adapt hardware measuring range
AnlgOutp <sup>5)</sup> (AnlgOvfl)	Analog output overloaded	Check display value-analog output assignment
StoreMin (PkMinOvf)	Minimum peak value overflow	1. Use external remote control to clear peak value or 2. In the PEAK STORE group, “ClearPkV” Yes
StoreMax (PkMaxOvf)	Maximum peak value overflow	1. Use external remote control to clear peak value or 2. In the PEAK STORE group, “ClearPkV” Yes
Net <sup>5)</sup> (Net+Ovf; Net-Ovf)	Net value overflow <sup>3)</sup>	Reduce display by one decimal place
Gross <sup>5)</sup> (Grs+Ovf; Grs-Ovf)	Gross value overflow <sup>3)</sup>	Reduce display by one decimal place
NomVal over <sup>5)</sup>	Nominal (rated) value exceeded	Adapt measuring range
Transducer <sup>5)</sup>	Transducer not connected No sense leads connected	Connect transducers Connect sense leads
Scaling <sup>4)</sup> (Scal.Err)	Input characteristic too steep	Modify input characteristic
AnlgScal (AScalErr)	Input or output characteristic too steep	Modify input or output characteristic
ISyncErr	No internal synchronization	Restart, connect transducer
(UrCalErr) <sup>5)</sup>	No valid initial calibration values	Restart, send the PME to the manufacturer (HBM)
CAN Tx <sup>5)</sup>	PDOs are not accepted at the bus	Check the CAN Bus configuration

1) Error messages without brackets: errors displayed continuously in 'ERROR' display mode.

2) Error messages in brackets: Errors displayed in the appropriate display mode (e.g. Gross, Net, Analog output signal).

3) ± 1 000 000 is output on the CAN Bus

4) see page 33

5) With the “Error” setting, the error message is signaled via the digital output

Operating state:

LED color	Status	Meaning	
		Measuring mode	Bus mode
Green	Steady light	Ready for measurement	CAN Operational (PDO transfer possible)
Green	Flashes	Data being transmitted over the interface	-
Yellow	Steady light	Ready for measurement	CAN Bus PreOperational (PDO transfer not possible)

LED color	Status	Meaning		Remedy
		Measuring mode	Bus mode	
Red	Flashes	Measured value overflow  LCD error  Transducer resistance too low	-	Adapt measuring range Restart  Reduce excitation voltage
Red	Steady light	Initialization phase: not (yet) ready for measurement, calibration error  No internal synchronization  Initial calibration error	CAN Bus not ready for communication	Wait  Connect transducer, possibly restart Send the PME to the manufacturer (HBM)

**9 Index****A**

Additional functions, 40, 53  
Additional spring, 15  
Address, 39  
Amplifier settings, 10  
Analog output, 11, 12, 16, 17, 36, 51, 56

**B**

Baud rate, 39  
Bessel, 35  
Bridge excitation voltage, 11, 12  
Bridge type, 11, 12  
Butterworth, 35

**C**

CAN Bus, 16, 22, 32, 39, 62  
    connection, 16  
CAN interface, 21, 41, 55  
CAN interface description, 41  
CANopen, 21  
CANopen interface, connection, 22  
Coding pin, 17  
Coding tab, 17  
Conditioning, 51, 56  
Configuration, 27  
Connection  
    CAN interface, 21  
    Supply voltage, 17  
    Transducers, 19  
Control inputs, 16, 18, 38  
Control inputs and outputs, 9, 16  
Control outputs, 16, 18  
Current value, 39  
Cyclic transmission of measured values,  
    41

**D**

Dialog, 48  
Digital input, 17  
Digital inputs/outputs, 54  
Digital output, 17  
DIP switch, 10  
Discharge rate, 37  
Dismounting, 14  
Display adaptation, 49  
Display mode, 26  
display resolution, 33

**E**

Error acknowledgement, 43  
Error message, 26, 27, 61

**F**

Factory setting, 11  
Factory settings, 12  
Feedback bridges, 20  
Filter, 35  
Flat ribbon cable, 23  
Four-wire configuration, 19  
Function test, 27  
Functions, 55

**H**

Hysteresis, 37

**I**

Input range, 11, 12  
Input remote controls, 38  
Inputs, 38  
Interface, connection, 22

**L**

LED, 62  
 level, 37  
 Limit value, 37  
 Limit value level, 37  
 Limit value switch, 52, 57

**M**

Mains power failure, 17  
 Measured value, 47, 56  
 Measuring mode, 25  
 Mounting, 14

**O**

Object dictionary, 44, 47  
 ON delay, 37  
 Output characteristic, 36  
 Output rate, 39  
 Output remote controls, 38  
 Outputs, 38

**P**

Parameter  
   read, write, 42  
   recall, save, 33  
 Parameters, 28  
   Description, 33  
   setting, 29  
 Password, 25, 33  
 Peak value, 37, 38, 39, 53, 57, 61  
 Peak–value store, 37  
 PLC, 42  
 PLC connection, 18  
 Plug terminal, 16, 17  
   Voltage supply, CAN Bus,  
   Synchronization, Control inputs,  
   Control outputs, 16  
 Plug terminal assignment, 17  
 Profile, 39

**R**

Recall, 33  
 Reference zero, 40  
 Remote controls, 38

**S**

Save, 33  
 Scale factor, 36  
 Scaling, 33, 36  
 Scaling factor, 33  
 Scaling range, 36  
 Set to zero, 34  
 Setting, 24, 27  
 Setting mode, 25  
 Setting parameters, 29  
 Setting the amplifier, 12  
 Standstill, 26  
 Standstill indication., 40  
 Standstill time, 40  
 Starting up, 27  
 Supply voltage, 17  
 Switch convention, 10  
 Switching direction, 37  
 Synchronization, 11, 13, 16, 23, 62

**T**

Taring, 34  
 Termination resistor, 13, 22  
 Transducer connection, 16  
   Strain gage full and half–bridges,  
   Inductive full and half bridges,  
   Potentiometric, Piezoelectric, LVDT,  
   19  
 Transducer excitation, 16  
 Transducers, 49, 56

**V**

Voltage supply, 16, 17



**Z**

Zero balance, 34

Zero offset, 34

Zero value, 34





© Hottinger Baldwin Messtechnik GmbH.

All rights reserved.

All details describe our products in general form only.

They are not to be understood as express warranty and do not constitute any liability whatsoever.

**Hottinger Baldwin Messtechnik GmbH**

Im Tiefen See 45 • 64293 Darmstadt • Germany

Tel. +49 6151 803-0 • Fax: +49 6151 803-9100

Email: [info@hbm.com](mailto:info@hbm.com) • [www.hbm.com](http://www.hbm.com)

measure and predict with confidence

